

# CERTIFIED COPY OF ORDER

STATE OF MISSOURI

January Session of the January Adjourned

Term. 20 16

County of Boone

} ea.

In the County Commission of said county, on the

7th

day of

January

20 16

the following, among other proceedings, were had, viz:

Now on this day the County Commission of the County of Boone does hereby approve the utilization of the Missouri Department of Transportation Cooperative Contract 3-140926TV – Light Duty Vehicles to purchase two (2) Chevrolet Silverado Half Ton 4x4 Extended Cap Pickup Trucks for Facilities Maintenance from Putnam Chevrolet Inc. of California, MO and to dispose of one (1) 1997 Ford Aerostar Van, asset tag 11019.

The terms of the Cooperative Contract are stipulated in the attached Purchase Agreement. It is further ordered the Presiding Commissioner is hereby authorized to sign said Purchase Agreement and Request for Disposal Form.

Done this 7th day of January, 2016.

ATTEST:

Wendy S. Noren  
Wendy S. Noren  
Clerk of the County Commission

Daniel K. Atwill  
Presiding Commissioner

Karen M. Miller  
District I Commissioner

Absent

Janet M. Thompson  
District II Commissioner

# BOONE COUNTY

## REQUEST FOR DISPOSAL/TRANSFER OF COUNTY PROPERTY

DATE: 11-23-15

FIXED ASSET TAG NUMBER: 11019

RECEIVED

DEC 22 2015

DESCRIPTION: 1997 FORD AEROSTAR VAN

BOONE COUNTY AUDITOR

REQUESTED MEANS OF DISPOSAL: GOV DEALS.COM OR Auto Auction

OTHER INFORMATION: 104,000 miles

CONDITION OF ASSET: POOR

REASON FOR DISPOSITION: Body is rusting badly and is in poor condition

COUNTY / COURT IT DEPT. (circle one) DOES /DOES NOT (circle one) WISH TO TRANSFER THIS ITEM FOR ITS OWN USE (this item is applicable to computer equipment only)

LOCATION OF ASSET AND DESIRED DATE FOR ASSET REMOVAL TO STORAGE: REMOVAL when REPLACEMENT

WAS ASSET PURCHASED WITH GRANT FUNDING? YES  NO   
IF YES, ATTACH DOCUMENTATION SHOWING FUNDING AGENCY'S PERMISSION TO DISPOSE OF ASSET.

DEPARTMENT: Facility Maintenance SIGNATURE R. Davidson

### AUDITOR

ORIGINAL PURCHASE DATE 5-21-97

RECEIPT INTO 6100-3835 HA

ORIGINAL COST \$15,061.95

GRANT FUNDED (Y/N) N

ORIGINAL FUNDING SOURCE 2784

GRANT NAME \_\_\_\_\_

% FUNDING \_\_\_\_\_

AGENCY \_\_\_\_\_

ASSET GROUP 1605

DOCUMENTATION ATTACHED (Y/N) \_\_\_\_\_

TRANSFER CONFIRMED \_\_\_\_\_

### COUNTY COMMISSION / COUNTY CLERK

APPROVED DISPOSAL METHOD:

\_\_\_\_ TRANSFER DEPARTMENT NAME \_\_\_\_\_ NUMBER \_\_\_\_\_

LOCATION WITHIN DEPARTMENT \_\_\_\_\_

INDIVIDUAL \_\_\_\_\_

\_\_\_\_ TRADE \_\_\_\_ AUCTION \_\_\_\_ SEALED BIDS

\_\_\_\_ OTHER EXPLAIN \_\_\_\_\_

COMMISSION ORDER NUMBER 11-2016

DATE APPROVED 1-7-16

SIGNATURE [Signature]

11-2016

# Boone County Purchasing

**Melinda Bobbitt, CPPO**  
Director of Purchasing



613 E. Ash Street, Room 110  
Columbia, MO 65201  
Phone: (573) 886-4391  
Fax: (573) 886-4390

---

## MEMORANDUM

**TO:** Boone County Commission  
**FROM:** Melinda Bobbitt, CPPB  
**DATE:** December 22, 2015  
**RE:** Cooperative Contract: 3-140926TV – (2) Chevrolet Silverado Pickup Trucks for Facilities Maintenance

Facilities Maintenance requests permission to utilize the Missouri Department of Transportation cooperative contract *3-140926TV – Light Duty Vehicles* with Putnam Chevrolet Inc. of California, Missouri to purchase two (2) Chevrolet Silverado Half Ton 4X4 Extended Cab Pickup Trucks.

One truck will be purchased from department 6100 – Facilities and Grounds Maintenance, account 92400 – Replacement Auto/Trucks and the other truck will be purchased from department 2705 – Facilities Maintenance/Housekeeping/Grounds ECC, account 91400 – Auto/Trucks. Trucks are \$27,533 each with \$31,000 budgeted per truck.

The Purchasing Department requests permission to dispose of the following surplus by auction:

1997 Ford Aerostar Van, fixed asset tag 11019

Attached is the Disposal Form for signature.

cc: Bob Davidson, Facilities  
Contract File

**PURCHASE AGREEMENT  
FOR**

**(2) New 2016 Chevrolet Silverado Half Ton 4x4 Extended Cab Pickup Trucks  
for the Boone County Facilities Maintenance Department**

**THIS AGREEMENT** dated the 7th day of January 2016 is made between Boone County, Missouri, a political subdivision of the State of Missouri through the Boone County Commission, herein "County" and **PUTNAM CHEVROLET INC** herein "Vendor."

**IN CONSIDERATION** of the parties performance of the respective obligations contained herein, the parties agree as follows:

1. **Contract Documents** - This agreement shall consist of this Purchase Agreement for two (2) new 2016 Chevrolet Silverado Half Ton 4x4 Extended Cab Pickup Trucks in compliance with all bid specifications and any addendum issued for the Missouri Department of Transportation Contract **3-140926TV**, Gary Hamilton's e-mail and quote dated November 21, 2015, and Boone County Standard Terms and Conditions. All such documents shall constitute the contract documents which are incorporated herein by reference. Service or product data, specification and literature submitted with bid response may be permanently maintained in the County Purchasing Office contract file for this contract if not attached. In the event of conflict between any of the foregoing documents, this Purchase Agreement, the Missouri Department of Transportation Contract **3-140926TV** and Boone County Standard Terms and Conditions shall prevail and control over the vendor's bid response.

2. **Purchase** - The County agrees to purchase from the Vendor and the Vendor agrees to supply the County two (2) of the following:

	<u>Unit Price</u>
2016 Chevrolet Silverado Half Ton 4x4 Extended Cab Pickup Truck	\$24,793.00
<u>Optional Equipment from Contract 3-140926TV</u>	
Option 9A Tow Pkg.	\$340.00
Option 9D Alt. larger V8 gasoline engine	\$980.00
Option 9K Limited Slip Rear Axle	\$360.00
Option 9O Blue Tooth Capability	\$150.00
<u>Optional Equipment included on quote dated January 1, 2015</u>	
Option: Rear Window Defogger	\$158.00
Option: Fleet Convenience Package	\$324.00
Option: Spray in Liner	\$428.00
<b>SUB-TOTAL</b>	<b>\$27,533.00</b>
<b>GRAND TOTAL FOR TWO (2) TRUCKS</b>	<b>\$55,066.00</b>

Exterior Color: Summit White  
Interior Color: Dark Ash, vinyl seats

3. **Delivery** - Vendor agrees to deliver vehicle as set forth in the bid documents and within 60-90 days after receipt of order. Delivery shall be to Boone County Public Works Department, Attn: Greg Edington, 5551 Tom Bass Road, Columbia, MO 65201.

4. **Title** - Title in the name of: Boone County Facilities Maintenance Department. Address: 613 E. Ash Street, Room 110, Columbia, MO 65201.

5. **Billing and Payment** - All billing shall be invoiced to the Boone County Facilities Maintenance Department, Attn: Jody Moore, 613 E Ash Street, Columbia, MO 65201 and billings may only include the prices listed herein. No additional fees for paper work processing, labor, or taxes shall be included as additional charges. The County agrees to pay all invoices within thirty days of receipt. In the event of a billing dispute, the County reserves the right to withhold payment on the disputed amount; in the event the billing dispute is resolved in favor of the Vendor, the County agrees to pay interest at a rate of 9% per annum on disputed amounts withheld commencing from the last date that payment was due.

6. **Binding Effect** - This agreement shall be binding upon the parties hereto and their successors and assigns for so long as this agreement remains in full force and effect.

7. **Termination** - This agreement may be terminated by the County upon thirty days advance written notice for any of the following reasons or under any of the following circumstances:

- a. County may terminate this agreement due to material breach of any term or condition of this agreement, or
- b. County may terminate this agreement if in the opinion of the Boone County Commission if delivery of products are delayed or products delivered are not in conformity with bidding specifications or variances authorized by County, or
- c. If appropriations are not made available and budgeted for any calendar year.

**IN WITNESS WHEREOF** the parties through their duly authorized representatives have executed this agreement on the day and year first above written.

**PUTNAM CHEVROLET INC.**

by [Signature]

title Fleet Sales

**BOONE COUNTY, MISSOURI**

by Boone County Commission

[Signature]  
Daniel K. Atwill, Presiding Commissioner

APPROVED AS TO FORM:

by: [Signature]  
County Counselor

ATTEST:

[Signature]  
Wendy S. Noren, County Clerk

**AUDITOR CERTIFICATION**

In accordance with RSMo 50.660, I hereby certify that a sufficient unencumbered appropriation balance exists and is available to satisfy the obligation(s) arising from this contract. (Note: Certification of this contract is not required if the terms of this contract do not create a measurable county obligation at this time.)

[Signature]  
Signature by [initials]

12/23/15  
Date

6100 / 92400 - \$27,533; 2705 / 91400 - \$27,533

Appropriation Account

## STANDARD CONTRACT TERMS AND CONDITIONS - BOONE COUNTY, MISSOURI

1. Contractor shall comply with all applicable federal, state, and local laws and failure to do so, in County's sole discretion, shall give County the right to terminate this Contract.
2. Prices shall include all charges for packing, delivery, installation, etc., (unless otherwise specified) to the Boone County Department.
3. The Boone County Commission has the right to accept or reject any part or parts of all bids, to waive technicalities, and to accept the offer the County Commission considers the most advantageous to the County. Boone County reserves the right to award this bid on an item-by-item basis, or an "all or none" basis, whichever is in the best interest of the County. The Purchasing Director reserves the right, when only one bid has been received by the bid closing date, to delay the opening of bids to another date and time in order to revise specifications and/or establish further competition for the commodity or service required. The one (1) bid received will be retained unopened until the new Closing date, or at request of bidder, returned unopened for re-submittal at the new date and time of bid closing.
4. When products or materials of any particular producer or manufacturer are mentioned in our contracts, such products or materials are intended to be descriptive of type or quality and not restricted to those mentioned.
5. Do not include Federal Excise Tax or Sales and Use Taxes in billing, as law exempts the County from them.
6. The delivery date shall be stated in definite terms.
7. The County Commission reserves the right to cancel all or any part of orders if delivery is not made or work is not started as guaranteed. In case of delay, the Contractor must notify the Purchasing Department.
8. In case of default by the Contractor, the County of Boone will procure the articles or services from other sources and hold the Contractor responsible for any excess cost occasioned thereby.
9. Failure to deliver as guaranteed may disqualify Contractor from future bidding.
10. Prices must be as stated in units of quantity specified, and must be firm.
11. The County of Boone, Missouri expressly denies responsibility for, or ownership of any item purchased until same is delivered to the County and is accepted by the County.
12. The County reserves the right to award to one or multiple respondents. The County also reserves the right to not award any item or group of items if the services can be obtained from a state or other governmental entities contract under more favorable terms.
13. The County, from time to time, uses federal grant funds for the procurement of goods and services. Accordingly, the provider of goods and/or services shall comply with federal laws, rules and regulations applicable to the funds used by the County for said procurement, and contract clauses required by the federal government in such circumstances are incorporated herein by reference. These clauses can generally be found in the Federal Transit Administration's Best Practices Procurement Manual – Appendix A. Any questions regarding the applicability of federal clauses to a particular bid should be directed to the Purchasing Department prior to bid opening.

14. In the event of a discrepancy between a unit price and an extended line item price, the unit price shall govern.
15. Should an audit of Contractor's invoices during the term of the Agreement, and any renewals thereof, indicate that the County has remitted payment on invoices that constitute an over-charging to the County above the pricing terms agreed to herein, the Contractor shall issue a refund check to the County for any over-charges within 30-days of being notified of the same.
16. **For all titled vehicles and equipment the dealer must use the actual delivery date to the County** on all transfer documents including the Certificate of Origin (COO,) Manufacturer's Statement of Origin (MSO,) Bill of Sale (BOS,) and Application for Title.
17. **Equipment and serial and model numbers** - The contractor is strongly encouraged to include equipment serial and model numbers for all amounts invoiced to the County. If equipment serial and model numbers are not provided on the face of the invoice, such information may be required by the County before issuing payment.

# PUTNAM CHEVROLET, INC.

31304 HWY87  
PO BOX 168  
California, MO 65108  
[www.putnamchevrolet.com](http://www.putnamchevrolet.com)  
(573) 796-2131 Fax: (573) 796-4206

To Melinda Bobbitt,

Putnam Chevrolet would sell the following vehicles to Boone County.

As follows: 2) 2016 Chevrolet Silverado Double Cab 4x4	\$24793.00 each
Option: Tow Package	\$340.00
Option: V-8 Engine	\$980.00
Option: Locking Rear Differential	\$360.00
Option: Bluetooth Capability	\$150.00
Option: Rear Window Defogger	\$158.00
Option: Fleet Convenience Package	\$324.00
Option Spray in Liner	\$428.00
Total:	\$27533.00 each

There will be no delivery charge to Boone County for their purchase.

Thank you for your business,

Gary Hamilton "Fleet Sales"

573-796-2131 work

573-230-4617 cell

[gary@putnamchevrolet.com](mailto:gary@putnamchevrolet.com)



**From:** <gary@putnamchevrolet.com>  
**To:** "Melinda Bobbitt" <mbobbitt@boonecountymmo.org>  
**Date:** 11/21/2015 9:42 AM  
**Subject:** RE: Silverado for Boone County  
**Attachments:** 201511212134.pdf

Hello Melinda,

I have attached the new sheet with the correct prices (10% off) for the Rear Window Defogger, Fleet Convenience Package and Spray In Liner. I did state on the attachment there is no delivery charge to Boone County.

The white exterior color is Summit White. This is the only white available. You do have other colors choices available which are 1)Red Hot, 2)Silver, 3)Black, 4)Tungsten Metallic. For an extra cost of \$395.00 these two colors are available 1)Deep Ocean Blue Metallic, 2)Autumn Bronze.

The only interior color is Dark Ash with Jet Black interior accents in either vinyl (which is the standard option for w/t models) or cloth seats at no charge.

Thanks,  
Gary Hamilton

"Fleet Sales"

Putnam Chevrolet  
31304 Highway 87  
P.O. Box 168  
California, Mo 65018

573-796-2131 work  
573-230-4617 cell  
573-796-4206 fax

-----Original Message-----

From: "Melinda Bobbitt" <mbobbitt@boonecountymmo.org>  
Sent: Friday, November 20, 2015 5:08pm  
To: gary@putnamchevrolet.com  
Subject: Silverado for Boone County

Gary,

On the attached quote that you provided to Bob Davidson in our Facilities Maintenance department, for the options of Rear Window Defogger, Fleet Convenience Package and Spray In Liner, the contract states that we get 10% off for those items. On your quote, has that discount already been taken or do we need to take that 10% off?

Also, with a white exterior, what are the options for interior color? Are there different white options or just one?

I also wanted to confirm that you are shipping to 65201 for no charge.

Thanks  
Melinda



**Missouri Department of Transportation**  
**RFB 3-140926TV Light Duty Vehicles - 1st Renewal**  
**Model Year 2016 Renewal Pricing**  
**Multiple Award**  
**ALL VENDORS ALLOW COOP PURCHASES**

**VENDOR INFORMATION**

**Name:** Blue Springs Ford  
**Contact name:** Mike Hilker  
**Address Line:** 3200 S. Outer Road  
**Address Line:** Blue Springs, MO 64015  
**Telephone #:** 816-229-4400  
**Cellular Phone #:** 816-896-1474  
**Email address:** [mhilker@bluespringsford.com](mailto:mhilker@bluespringsford.com)

**Name:** Capitol Chrysler Dodge Jeep Ram  
**Contact name:** Jerry Dunn  
**Address Line:** 3201 Missouri Blvd.  
**Address Line:** Jefferson City, MO 65109  
**Telephone #:** 573-893-5000  
**Cellular Phone #:** 573-301-2245  
**Email address:** [jdunn@capitolcitycars.com](mailto:jdunn@capitolcitycars.com)

**Name:** Don Brown Chevrolet  
**Contact name:** Dave Helderbrand  
**Address Line:** 2244 S. Kingshighway  
**Address Line:** St. Louis, MO 63110  
**Telephone #:** 314-772-1400  
**Cellular Phone #:** 314-333-6155  
**Email address:** [dave@donbrownchevrolet.com](mailto:dave@donbrownchevrolet.com)

**Name:** Lou Fusz Chevrolet  
**Contact name:** Brad Matheney  
**Address Line:** 5120 N. Service Rd.  
**Address Line:** St. Peter, MO 63376  
**Telephone #:** 314-595-2780  
**Cellular Phone #:** 314-565-0112  
**Email address:** [bradmatheney@fusz.com](mailto:bradmatheney@fusz.com)

**Name:** Lou Fusz Ford  
**Contact name:** Andy Eldridge  
**Address Line:** #2 Caprice Drive  
**Address Line:** Chesterfield, MO 63005  
**Telephone #:** 636-532-9955  
**Cellular Phone #:** 314-662-0055  
**Email address:** [andyeldridge@fusz.com](mailto:andyeldridge@fusz.com)

**Name:** Putnam Chevrolet  
**Contact name:** Bill Campbell; Gary Hamilton  
**Address Line:** 500 W. Buchanan, P.O. Box 168  
**Address Line:** California, MO 65018  
**Telephone #:** 573-796-2131  
**Email address:** [bjill@putnamchevrolet.com](mailto:bjill@putnamchevrolet.com)  
**Other E-Mail:** [gary@putnamchevrolet.com](mailto:gary@putnamchevrolet.com)

**Name:** Roberts Chevrolet Buick  
**Contact name:** Dean Meier  
**Address Line:** 1600 E. Prairie View Road, P.O. Box 470  
**Address Line:** Platte City, MO 64079  
**Telephone #:** 816-858-3200  
**Cellular Phone #:** 816-564-9678  
**Email address:** [fleet@robertscb.com](mailto:fleet@robertscb.com)

**VENDOR INFORMATION**

**Name:** Broadway Ford Truck Sales  
**Contact name:** Terry Wojtowicz  
**Address Line:** 1506 South 7th Street  
**Address Line:** St. Louis, MO 63104  
**Telephone #:** 314-206-3330  
**Cellular Phone #:** 314-412-9140  
**Email address:** [twojowicz@broadwaytruck.com](mailto:twojowicz@broadwaytruck.com)

**Name:** Dave Sinclair Ford Inc.  
**Contact name:** Les Williams  
**Address Line:** 7466 S. Lindbergh  
**Address Line:** St. Louis, MO 63125  
**Telephone #:** 314-892-2600  
**Cellular Phone #:** 314-540-5266  
**Email address:** [lwilliams@davesinclair.com](mailto:lwilliams@davesinclair.com)

**Name:** Joe Machens Ford, Inc.  
**Contact name:** Kelly Sells  
**Address Line:** 1911 West Worley  
**Address Line:** Columbia, MO 65203  
**Telephone #:** 573-445-4411, ext. 119  
**Cellular Phone #:** NA  
**Email address:** [ksells@machens.com](mailto:ksells@machens.com)

**Name:** Lou Fusz GMC  
**Contact name:** Brad Matheney  
**Address Line:** 10950 Page Avenue  
**Address Line:** St. Louis, MO 63132  
**Telephone #:** 314-595-2780  
**Cellular Phone #:** 314-565-0112  
**Email address:** [bradmatheney@fusz.com](mailto:bradmatheney@fusz.com)

**Name:** Midway Ford Truck Center, Inc.  
**Contact name:** Kyle C. Mead  
**Address Line:** 7601 NE 38th Street  
**Address Line:** Kansas City, MO 64161  
**Telephone #:** 816-455-3000  
**Cellular Phone #:** 913-669-1987  
**Email address:** [kyle.mead@midwaytrucks.com](mailto:kyle.mead@midwaytrucks.com)

**Name:** Republic Ford, Inc.  
**Contact name:** Steve Forrester  
**Address Line:** P.O. Box 700  
**Address Line:** Republic, MO 65738  
**Telephone #:** 417-732-2626  
**Cellular Phone #:** 417-350-5083  
**Email address:** [sforrester@republicford.com](mailto:sforrester@republicford.com)

**Name:** Shawnee Mission Ford Inc.  
**Contact name:** Jay Cooper  
**Address Line:** 11501 W. Shawnee Mission Parkway  
**Address Line:** Box 3179  
**Address Line:** Shawnee, KS 66203-0179  
**Telephone #:** 913-248-2287  
**Email address:** [jay.cooper@shawneemissionford.com](mailto:jay.cooper@shawneemissionford.com)



**Missouri Department of Transportation  
RFB 3-140926TV Light Duty Vehicles - 1st Renewal  
2016 Model Year Renewal Pricing**

**% Discount off MSRP for all Data Book or Pricing Guide Options**

Vendor	% MSRP Discount	FOB Location
Blue Springs Ford	10%	Blue Springs, MO 64015
Broadway Ford Truck Sales	12%	St. Louis, MO 63104
Capitol Chrysler Dodge Jeep Ram	5%	Jefferson City, MO 65109
Dave Sinclair Ford, Inc.	10%	7466 S. Lindbergh St. Louis, MO
Don Brown Chevrolet	10%	2244 S. Kingshighway St. Louis, MO
Joe Machens Ford	10%	
Lou Fusz Chevrolet	0%	\$1.50/mile from 5120 N. Service Rd, St. Peters, MO
Lou Fusz Ford	3%	Chesterfield, MO
Lou Fusz GMC	0%	\$1.50/mile from 10950 Page Ave, St. Louis, MO
Midway Ford Truck Center, Inc.	5%	Midway Ford Truck Center
Republic Ford, Inc.	NONE	Republic, MO
Roberts Chevrolet, Inc.	10%	Platte City, MO
Putnam Chevrolet	10%	
Shawnee Mission Ford, Inc.	10%	Shawnee

**Manufacturer's Factory Warranties:**

**Dodge/Chrysler/Jeep: 3 Year/36,000 Mile Bumper to Bumper and 5 Year/100,000 Mile Powertrain**  
**Chevrolet/GMC: 3 Year/36,000 Mile Bumper to Bumper and 5 Year/100,000 Mile Powertrain Warranty**  
**Ford: 3 Year/36,000 Mile Bumper to Bumper and 5 Year/60,000 Mile Powertrain Warranty**



**Missouri Department of Transportation  
RFB 3-140926TV Light Duty Vehicles - 1st Renewal**

**Multiple Award  
2016 Model Year**

**Item Description**

- ITEM # 1 - New standard equipped 2016 Compact 4x2 Extended Cab**
- ITEM # 2 - New standard equipped 2016 Compact 4x2 Crew Cab**
- ITEM # 3 - New standard equipped 2016 Compact 4x4 Extended Cab**
- ITEM # 4 - New standard equipped 2016 Compact 4x4 Crew Cab**
- ITEM # 5 - New standard equipped 2016 Half-Ton 4x2 Regular Cab Pickup Truck**
- ITEM # 6 - New standard equipped 2016 Half-Ton 4x2 Extended Cab Pickup Truck**
- ITEM # 7 - New standard equipped 2016 Half-Ton 4x2 Crew Cab Pickup Truck**
- ITEM # 8 - New standard equipped 2016 Half-Ton 4x4 Regular Cab Pickup Truck**
- ITEM # 9 - New standard equipped 2016 Half-Ton 4x4 Extended Cab Pickup Truck**
- ITEM # 10 - New standard equipped 2016 Half-Ton 4x4 Crew Cab Pickup Truck**
- ITEM # 11 - New standard equipped 2016 (Compact) Sport Utility Vehicle 2WD**
- ITEM # 12 - New standard equipped 2016 (Compact) Sport Utility Vehicle 4WD or AWD**
- ITEM # 13 - New standard equipped 2016 (Full Size) Sport Utility Vehicle 2WD**
- ITEM # 14 - New standard equipped 2016 (Full Size) Sport Utility Vehicle 4WD or AWD**
- ITEM # 15 - New standard equipped 2016 or Newer 2WD Model Carryalls**
- ITEM # 16 - New standard equipped 2016 or Newer 4WD Model Carryalls**
- ITEM # 17 - New standard equipped 2016 7-Passenger Extended Mini-Van, Alternative Fuel**
- ITEM # 18 - New standard equipped 2016 Cargo Mini-Van**
- ITEM # 19 - New standard equipped 2016 Small-Size 4-Door Sedan**
- ITEM # 20 - New standard equipped 2016 Mid-Size 4-Door Sedan, Alternative Fuel**
- ITEM # 21 - New standard equipped 2016 Mid-Size 4-Door Sedan, Gas Engine**
- ITEM # 22 - New standard equipped 2016 Mid-Size 4-Door Sedan, Hybrid Engine**
- ITEM # 23 - New standard equipped 2016 Full Size 4-Door Sedan, Alternative Fuel**
- ITEM # 24 - New standard equipped 2016 Full Size 4-Door Sedan, Gas Engine**



**Missouri Department of Transportation**  
**Bid Tabulation of Request 3-140926TV Light Duty Vehicles - 1st Renewal**  
 Multiple Awards

**ITEM # 9 - New standard equipped 2016 Half-Ton 4 x 4 Extended Cab Pickup Truck**  
**Options A-Q apply. See Options Tab for details.**

VENDOR	Capital City Chrysler	Don Brown Chevrolet BID "A"	Don Brown Chevrolet BID "B"	Lou Fusz Chevrolet	Lou Fusz GMC	Putnam Chevrolet	Roberts Chevrolet Buick
MAKE/MODEL	DODGE RAM 1500 QUAD 4X4	CHEVROLET SILVERADO	CHEVROLET SILVERADO	CHEVROLET SILVERADO	GMC SIERRA	CHEVROLET SILVERADO	CHEVROLET SILVERADO 1500
GVWR	6,800	7,100	7,100	7,100	7,100	7,100	6,900
GAS MPG CITY / HWY	16 / 23	17 / 22	17 / 22	17 / 22	17 / 22	17 / 22	17 / 22
FUEL CAP	26	26	26	26	26	26	26
OIL CAP	6	6	6	5	5	6	6
E-85 Compatible	YES	YES	YES	YES	YES	YES	YES
E-85 MPG CITY / HWY	12 / 17	12 / 15	12 / 15	17 / 22	17 / 22	12 / 15	12 / 15
BASE PRICE	\$24,021.00	\$24,163.00	\$24,084.00	\$24,632.00	\$24,591.00	\$24,793.00	\$24,196.00
OPTION 9A Tow Pkg.	\$150.00	\$338.00	\$338.00	\$330.00	\$330.00	\$340.00	\$338.00
OPTION 9B Integrated Brake Control	\$280.00	\$205.00	\$205.00	\$202.00	\$202.00	\$207.00	\$207.00
OPTION 9C Ext. Color Highway Yellow	N/A	\$274.00	\$274.00	\$0.00	\$0.00	\$275.00	\$0.00
OPTION 9D Alt. larger V8 gasoline engine	(\$475.00)	\$1,035.00	\$1,035.00	\$996.00	\$996.00	\$980.00	\$985.00
OPTION 9E Alt. diesel engine	\$8,800.00	N/A	N/A		N/A	N/A	N/A
OPTION 9F Opt CNG LP Pkg	N/A	N/A	N/A	\$0.00	N/A	N/A	N/A
OPTION 9G Cab Steps / Run Boards	\$550.00	\$563.00	\$563.00	\$575.00	\$575.00	See Comments	\$567.00
OPTION 9H Power Windows/Door Locks	\$0.00	\$0.00	\$0.00	\$0.00	\$0.00	\$0.00	\$0.00
OPTION 9I Short Bed in lieu of 8' Bed	\$0.00	N/A	N/A	N/A	N/A	\$0.00	
OPTION 9J Opt. Rear Axle Ratio	\$75.00	N/A	N/A		N/A	N/A	\$0.00
OPTION 9K Limited Slip Rear Axle	\$370.00	\$367.00	\$367.00	\$360.00	\$360.00	\$360.00	\$356.00
OPTION 9L LT. 6 ply tires in lieu of 4 ply		\$363.00	\$363.00	\$350.00	\$350.00	\$353.00	\$356.00
OPTION 9M 10 ply tires in lieu of 4 ply	\$250.00	N/A	N/A		N/A	\$320.00	\$311.00
OPTION 9N Trailer Type ext. mirrors	\$180.00	\$67.00	\$67.00	\$64.00	\$64.00	\$68.00	\$63.00
OPTION 9O Bluetooth Capability	\$660.00	\$132.00	\$132.00	\$137.00	\$137.00	\$150.00	\$392.00
STD ARO (DAYS)	90-120	80	80	60-90	60-90	60-90	60-90



105 West Capitol Avenue  
 P.O. Box 270  
 Jefferson City, Missouri 65102

**Missouri Department of Transportation**  
*David B. Nichols, Director*

573.751.2551  
 Fax: 573.751.6555  
 1.888.ASK MODOT (275.6636)

**ADDENDUM 001  
 Light Duty Vehicles  
 Request for Bid 3-140926TV**

Bidders should acknowledge receipt of Addendum 001 (ONE) by **signing** and **including it** with the original bid. The due date for receipt of bids remains **unchanged** by this Addendum. Accordingly, the following clarifications are believed to be of general interest to all potential bidders. All other terms and conditions remain unchanged and in full force.

Name and Title of Signer (Print or type)	Name and Title of Department Authority  Name: Tom Veasman Title: Sr. General Services Specialist
Contractor/Bidder Signature	Department of Transportation  <i>Tom Veasman</i>
(Signature of person authorized to sign)	(Authorizing Signature)
Date Signed:	Date Signed: September 11, 2014

**Addendum on Items 7 and 10:**

- ITEM # 7** - New standard equipped **2015 Half-Ton 4 X 2 Crew Cab Pickup Truck** AND  
**ITEM # 10** - New standard equipped **2015 Half-Ton 4 X 4 Crew Cab Pickup Truck**

One of the standard requirements for both Item 7 and Item 10 was described as a "Long Bed - 5 ½ ft.". The requirement should instead be described as a "Short Bed - 5 ½ ft.".

**Options 7L and 10L**, described as "**Long Bed in lieu of the 5' 6" Bed**" are correctly worded. Please provide cost and state the length of longer bed that you can offer for Items #7L and #10L.



*Our mission is to provide a world-class transportation experience that delights our customers and promotes a prosperous Missouri.*

[www.modot.org](http://www.modot.org)

Missouri Department of Transportation  
*David B. Nichols, Director*

573.751.2551  
Fax: 573.751.6555  
1.888.ASK MODOT (275.6636)

**ADDENDUM 002  
Light Duty Vehicles  
Request for Bid 3-140926TV**

Bidders should acknowledge receipt of Addendum 002 (TWO) by **signing** and **including it** with the original bid. The due date for receipt of bids remains **unchanged** by this Addendum. Accordingly, the following clarifications are believed to be of general interest to all potential bidders. All other terms and conditions remain unchanged and in full force.

Name and Title of Signer (Print or type)	Name and Title of Department Authority  Name: Tom Veasman Title: Sr. General Services Specialist
Contractor/Bidder Signature  <hr/>	Department of Transportation  <hr/>
(Signature of person authorized to sign)	(Authorizing Signature)
Date Signed:	Date Signed: September 18, 2014

**Addendum on Item #13 and #14:**

**ITEM # 13** - New standard equipped **2015 (Full Size) Sport Utility Vehicle 2WD**

**ITEM # 14** - New standard equipped **2015 (Full Size) Sport Utility Vehicle 4WD or AWD**

The second and third row bench seats have been added as a standard requirement for Item #13 and #14. In addition, Options #13F and #14F have been added to allow the purchase of Item #13 and #14 without the third seat.

Bidders should remove the pricing pages for Item #13 and Item #14 from the original RFB and replace them with the attached REVISED Item #13 and REVISED Item #14 pricing pages.



*Our mission is to provide a world-class transportation experience that  
delights our customers and promotes a prosperous Missouri.*

[www.modot.org](http://www.modot.org)







BID FORM

MAILING ADDRESS:  
MISSOURI DEPARTMENT OF TRANSPORTATION  
GENERAL SERVICES, P.O. BOX 270  
JEFFERSON CITY, MO 65102

REQUEST NO.	3-140926TV
DATE	September 5, 2014

SEALED BIDS, SUBJECT TO THE ATTACHED CONDITIONS WILL BE RECEIVED AT THIS OFFICE UNTIL

**2:00 pm., Local Time, September 26, 2014**

AND THEN PUBLICLY OPENED AND READ FOR FURNISHING THE FOLLOWING EQUIPMENT.

**BIDS TO BE BASED F.O.B. MISSOURI DEPARTMENT OF TRANSPORTATION**

Submit net bid as cash discount stipulations will not be considered  
Various End User Delivery Locations

DEFINITE DELIVERY DATE SHOULD BE SHOWN. THE BIDDER MUST SIGN AND RETURN BEFORE DATE AND TIME SET FOR OPENING.

**BUYER:** Tom Veasman  
**BUYER EMAIL:**  
tom.veasman@modot.mo.gov

**BUYER TELEPHONE:** 573-522-4404

**LIGHT DUTY VEHICLES**

This Request For Bid seeks bids from qualified organizations to provide vehicles in accordance with the following pages. MoDOT will receive bids at the following mailing address: P.O. Box 270, Jefferson City, MO 65102-0270, or hand-delivered in a sealed envelope to the following **physical address: General Services Procurement at 830 MoDOT Drive, Jefferson City, MO 65109** until 2:00 p.m., September 26, 2014. Bid forms and information may be obtained by contacting Tom Veasman at 573-522-4404, [tom.veasman@modot.mo.gov](mailto:tom.veasman@modot.mo.gov), or electronically download them at: <http://www.modot.org/business/surplus/Fleet%20Buyers%20Web%20Page/LightDutyVehicles.htm>

**Components of Agreement:** The Agreement between MHTC and the successful Bidder(s) shall consist of: the RFB and any written amendments thereto, the "Standard Bid Provisions, General Terms and Conditions and Special Terms and Conditions" that are attached to this RFB and the bid submitted by the Bidder in response to the RFB. However, MHTC reserves the right to clarify any relationship in writing and such written clarification shall govern in case of conflict with the applicable requirements stated in the RFB or the Bidder's bid. The Bidder is cautioned that its bid shall be subject to acceptance by MHTC without further clarification.

**Return sealed bid to the address shown at the top of this page to the attention of the buyer. Submission of bids to the above mailing address must go through MoDOT's mail room and will require additional time to arrive at 830 MoDOT Drive.**

(SEE ATTACHED FOR TERMS, CONDITIONS, AND INSTRUCTIONS)

*In compliance with the above Request For Bid, and subject to all conditions thereof, the undersigned bidder agrees to furnish and deliver any or all the items on which prices were bid within the timeframe specified herein, after receipt of formal purchase order.*

**Date:** \_\_\_\_\_  
**Telephone No.:** \_\_\_\_\_  
**Fax No.:** \_\_\_\_\_  
**Federal I.D. No.** \_\_\_\_\_  
**Email Address:** \_\_\_\_\_

**Firm Name:** \_\_\_\_\_  
**Address:** \_\_\_\_\_  
**By (Signature):** \_\_\_\_\_  
**Type/Print Name** \_\_\_\_\_

**Is your firm MBE certified?**  Yes  No

**Title:** \_\_\_\_\_  
**Is your firm WBE certified?**  Yes  No

## 1. INTRODUCTION AND GENERAL INFORMATION

### 1.1 Introduction:

- 1.1.1 This Request for Bid (RFB) seeks bids from qualified organizations to provide light duty vehicles for the locations in the State of Missouri (See Section 2.3.2) through the end of the 2015 model year, to the Missouri Highways and Transportation Commission (MHTC) and Missouri Department of Transportation (MoDOT). Each bid must be in a sealed envelope, be mailed or delivered by courier to the RFB Coordinator at the below listed address, on or before the date and time listed herein for receipt of bids/proposals. All questions regarding the RFB shall be submitted to the RFB Coordinator. **Bids must be returned to the office of the RFB Coordinator no later than 2:00 p.m. Local Time, September 26, 2014.**

#### **RFB COORDINATOR:**

**Tom Veasman, Senior General Services Specialist**

#### **MAILING ADDRESS:**

**Missouri Department of Transportation  
P. O. Box 270  
Jefferson City, MO 65102  
Attn: Tom Veasman**

#### **PHYSICAL ADDRESS:**

**Missouri Department of Transportation  
General Services Division  
830 MoDOT Drive  
Jefferson City, MO 65109**

Note that submission of bids to the above **mailing address** must go through MoDOT's mail room and will require additional time to arrive at 830 MoDOT Drive.

**PHONE: 573-522-4404**

**FAX: 573-526-6948**

### 1.2 General Information:

- 1.2.1 This document constitutes an invitation for competitive, sealed bids for the procurement of light duty vehicles as set forth herein.
- 1.2.2 Organization: This RFB is divided into the following parts:
- 1) Introduction and General Information
  - 2) Scope of Work
  - 3) Bid Submission
  - 4) Pricing Page(s)
  - 5) Vendor Information and Preference Certification Form
  - 6) Notice Of Cooperative Purchasing
  - 7) Anti-Collusion Statement
  - 8) Terms and Conditions

## 2. SCOPE OF WORK

### 2.1 General Requirements:

- 2.1.1 The contractor shall provide light duty vehicles on an as needed, if needed basis for the MHTC and MoDOT, in accordance with the provisions and requirements stated herein.
- 2.1.2 The contractor shall provide all deliverables/services to the sole satisfaction of MoDOT.
- 2.1.3 MoDOT reserves the right to obtain "like or similar" products as specified herein from other manufacturers, exclusive of the contract, when use of such products is deemed in the best interest of MoDOT.
- 2.1.4 Unless otherwise specified herein, the contractor shall furnish all material, labor, facilities, equipment, and supplies necessary to provide the deliverables/services required herein.
- 2.1.5 MoDOT reserves the right to reject any or all bids, and to accept or reject any items thereon, and to waive technicalities. In case of error in the extension of prices in the bid/quote/proposal, unit prices will govern.
- 2.1.6 This work is to be performed under the general supervision and direction of MoDOT and, if awarded any portion of the work, the Contractor agrees to furnish at his own expense all labor and equipment required to complete the work, it being expressly understood that this solicitation is for completed work based upon the price(s) specified and is not a solicitation for rental of equipment or employment of labor by MoDOT, and MoDOT is to have no direction or control over the employees used by the Contractor in performance of the work.

### 2.2 Required Specifications:

All materials, equipment, and/or services bid upon must comply with the included MoDOT specifications and any other provisions outlined in the solicitation documents.

### 2.3 Delivery Requirements:

- 2.3.1 The following delivery requirements shall apply:
  - a. Unless otherwise specified on the solicitation documents or purchase order, suppliers shall give at least 24 hours advance notice of each delivery. Delivery will only be received between the hours of 8:00 a.m. to 3:00 p.m., Monday through Friday. No vehicles will be received on Saturday, Sunday or state holidays.
  - b. If the prices bid herein include the delivery cost of the material, the Contractor agrees to pay all transportation charges on the material as FOB - Destination. Freight costs must be included in the unit price bid and not listed as a separate line item.
  - c. Any demurrage is to be paid by the Contractor direct to the railroad or carrier.
- 2.3.2 The contractor shall deliver the products specified herein to the following MoDOT locations:
  - a. St. Joseph, Missouri 64502
  - b. Macon, Missouri 63552
  - c. Hannibal, Missouri 63401
  - d. Lee's Summit, Missouri 64064-8002
  - e. Jefferson City, Missouri 65102
  - f. Chesterfield, Missouri 63017-5712
  - g. Joplin, Missouri 64802
  - h. Springfield, Missouri 65801
  - i. Willow Springs, Missouri 65793
  - j. Sikeston, Missouri 63801

## **2.4 Contract/Purchase Order:**

- 2.4.1 The contract expresses the complete agreement of the parties and performance shall be governed solely by the specifications and requirements contained therein. Any change, whether by modification and/or supplementation, must be accomplished by a formal contract amendment signed and approved by and between the duly authorized representative of the Contractor and the duly authorized representative of the MHTC, by a modified purchase order prior to the effective date of such modification. The Contractor expressly and explicitly understands and agrees that no other method and/or no other document, including correspondence, acts, and oral communications by or from any person, shall be used or construed as an amendment or modification

## **2.5 Invoicing and Payment Requirements:**

- 2.5.1 The contractor shall submit an itemized invoice to the applicable requesting address for the completion of deliverables, as specified herein.
- 2.5.2 Each invoice should be itemized in accordance with items listed on the purchase order and/or contract. The statewide financial management system has been designed to capture certain receipt and payment information. Therefore, each invoice submitted must reference the purchase order number and must be itemized in accordance with items listed on the purchase order. Failure to comply with this requirement may delay processing of invoices for payment.
- 2.5.3 The contractor shall be paid in accordance with the firm, fixed prices stated on the pricing page of this document after completion of deliverables specified herein and acceptance by MoDOT.
- 2.5.4 Other than the payment specified above, no other payments or reimbursements shall be made to the contractor for any reason whatsoever.
- 2.5.5 Unless otherwise provided for in the solicitation documents, payment for all equipment, supplies, and/or services required herein shall be made in arrears. The MHTC shall not make any advance deposits.
- 2.5.6 The MHTC assumes no obligation for equipment, supplies, and/or services shipped or provided in excess of the quantity ordered. Any authorized quantity is subject to the MHTC's rejection and shall be returned at the contractor's expense.
- 2.5.7 The MHTC reserves the right to purchase goods and services using the state-purchasing card.

## **2.6 Other Contractual Requirements:**

- 2.6.1 Contract Period - The contract shall commence from the date of award until the end of the model year with up to two (2) one-year renewal option periods, or any portion therein. If the option for renewal is exercised by MoDOT, the contractor shall agree to all terms and conditions of the RFB and all subsequent amendments. Renewal options are at the sole discretion of MoDOT.
- 2.6.2 Escalation Clause - In the event the contractor requests a price increase during the contract period, either the original contract period or any contract renewal period, the contractor must provide a written request and documentation justifying the need for a price increase, and the amount of such price increase. MoDOT will review the contractor's written request and documentation, and decide if a price increase is to be granted at that particular time. The contractor shall understand and agree that MoDOT's decision shall be final and without recourse. No price increase shall be granted during the first 3 months of the original contract period, or if applicable, first 3 months of a contract renewal period.

2.6.3 Inspection and Acceptance: MoDOT reserves the right to inspect the material at the point of manufacture, intermediate storage point, or at a destination which shall be at the discretion of MoDOT.

- a. No equipment, supplies, and/or services received by MoDOT pursuant to a contract shall be deemed accepted until MoDOT has had reasonable opportunity to inspect said equipment, supplies, and/or services.
- b. All equipment, supplies, and/or services which do not comply with the specifications and/or requirements or which are otherwise unacceptable or defective may be rejected. In addition, all equipment, supplies, and/or services which are discovered to be defective or which do not conform to any warranty of the Contractor upon inspection (or at any later time if the defects contained were not reasonably ascertainable upon the initial inspection) may be rejected.
- c. The MHTC reserves the right to return any such rejected shipment at the Contractor's expense for full credit or replacement and to specify a reasonable date by which replacements must be received.
- d. The MHTC's right to reject any unacceptable equipment, supplies, and/or services shall not exclude any other legal, equitable or contractual remedies the MHTC may have.

2.6.4 Net Delivered Price - the unit(s) shall be delivered complete and ready for use to the delivery destinations.

### 3. BID SUBMISSION

#### 3.1 Bid Submission Information:

- 3.1.1 All bids must be received in a sealed envelope/package clearly marked “**3-140926TV Light Duty Vehicles**”.
- 3.1.2 All bids must be received at the office of the RFB Coordinator as outlined in Section 1. “INTRODUCTION AND GENERAL INFORMATION”.
- 3.1.3 The bidder may withdraw, modify or correct his/her bid after it has been deposited with MoDOT provided such request is submitted in writing and received at the location designated for the bid opening prior to the date and time specified for opening bids. Such a request received as specified will be attached to the bid and the bid will be considered to have been modified accordingly. No bid may be modified after the date and time specified for the opening of bids.
- 3.1.4 Open Competition / Request For Bid Document:
- a. It shall be the bidder's responsibility to ask questions, request changes or clarification, or otherwise advise MoDOT if any language, specifications or requirements of an RFB appear to be ambiguous, contradictory, and/or arbitrary, or appear to inadvertently restrict or limit the requirements stated in the RFB to a single source. Any and all communication from bidders regarding specifications, requirements, competitive bid process, etc., must be directed to the buyer from MoDOT, unless the RFB specifically refers the bidder to another contact. Such communication should be received at least three (3) working days prior to the official bid opening date.
  - b. Every attempt shall be made to ensure that the bidder receives an adequate and prompt response. However, in order to maintain a fair and equitable bid process, all bidders will be advised, via the issuance of an amendment to the RFB, of any relevant or pertinent information related to the procurement. Therefore, bidders are advised that unless specified elsewhere in the RFB, any questions received less than three (3) working days prior to the RFB opening date may not be answered.
  - c. Bidders are cautioned that the only official position of the MoDOT is that which is issued by MoDOT in the RFB or an amendment thereto. No other means of communication, whether oral or written, shall be construed as a formal or official response or statement.
  - d. MoDOT monitors all procurement activities to detect any possibility of deliberate restraint of competition, collusion among bidders, price-fixing by bidders, or any other anticompetitive conduct by bidders which appears to violate state and federal antitrust laws. Any suspected violation shall be referred to the Missouri Attorney General's Office for appropriate action.
- 3.1.5 Bid Review: Bids will be reviewed to determine if the bid complies with the mandatory requirements, and to determine the lowest and best bid.
- 3.1.6 Contract Award: This is a Multiple Award bid and there will be no ‘one’ bidder awarded each item within this bid. Each individual delivery destination will have sole responsibility for the discretion of all purchasing decisions. Criteria used to determine purchasing decisions are price, location of servicing dealers, past performance of servicing dealers, and past performance of different makes and models.
- a. Notification of award shall be at the time the tabulation is posted to the Internet. It is the sole responsibility for all bidders to check the website for bid results.

**ITEM # 1 - New standard equipped 2015 Compact 4 X 2 Extended Cab**

**ACCEPTABLE MAKES AND MODELS:**

Chevrolet Colorado / GMC Canyon

**All units must contain the following options:**

1. Standard 2.5 Liter minimum gasoline engine (Size \_\_\_\_\_ Horsepower \_\_\_\_\_)
2. Manufacturer's standard rear end axle ratio (Ratio: \_\_\_\_\_)
3. Automatic transmission (Speeds \_\_\_\_\_)
4. Air conditioning
5. LH & RH exterior mirrors
6. Tires: (4) manufacturer's standard all season, plus compact spare wheel and tire (Size) \_\_\_\_\_
7. Rubber flooring
8. Minimum 5,400 lbs. GVWR
9. Bed: Minimum 6 Feet
10. Brakes, 4 wheel anti-lock braking system (ABS)
11. Speed control and tilt wheel
12. Cloth seats
13. 3 sets of keys

**DEALER COMPLETE IN DETAIL:**

2015 MAKE \_\_\_\_\_ MODEL \_\_\_\_\_ GVWR \_\_\_\_\_ EACH \$ \_\_\_\_\_

GAS MPG: CITY \_\_\_\_\_ HWY \_\_\_\_\_ FUEL CAPACITY \_\_\_\_\_ OIL CAPACITY \_\_\_\_\_

IS THIS ENGINE E-85 COMPATIBLE? \_\_\_\_\_ IF SO WHAT IS E-85 MPG: CITY \_\_\_\_\_ HWY \_\_\_\_\_

BUMPER TO BUMPER WARRANTY \_\_\_\_\_

POWERTRAIN WARRANTY \_\_\_\_\_

EXTENDED WARRANTY \_\_\_\_\_

**OPTIONAL EQUIPMENT PRICES, Item # 1**

Indicate the additional cost or deduction for the below listed options. Price should include all required options and special equipment.

**Option 1A. Towing Package: Manufacturer's Standard to include frame hitch / receiver and 7 pin trailer wiring connection**

EACH \$ \_\_\_\_\_

**Option 1B. Exterior color to be Federal Standard #595B "Highway Yellow"**

EACH \$ \_\_\_\_\_

**Option 1C. Alternate V6 Gas Engine (state size and horsepower) E-85 compatible? \_\_\_\_\_**

EACH \$ \_\_\_\_\_ SIZE \_\_\_\_\_ HORSEPOWER \_\_\_\_\_

**Option 1D. 2 Full-length factory cab steps or running boards (One on Drivers Side, one on Passenger side)**

SET \$ \_\_\_\_\_

**Option 1E. Power Windows and Door Locks**

EACH \$ \_\_\_\_\_



**OPTIONAL EQUIPMENT PRICES, Item # 1 continued**

**Option 1F.      Optional Rear Axle Ratio      Axle Ratio \_\_\_\_\_**

**EACH \$ \_\_\_\_\_**

**Option 1G.      Limited Slip Rear Axle      Axle Ratio \_\_\_\_\_**

**EACH \$ \_\_\_\_\_**

**Option 1H.      LT. 6 ply tires in lieu of 4 ply standard tires      Size \_\_\_\_\_**

**EACH \$ \_\_\_\_\_**

**Option 1I.      Bluetooth Capability**

**EACH \$ \_\_\_\_\_**

**Please submit a complete parts list with detailed pricing information for each make/model your company would be willing to provide.** Please indicate below the percent (%) discount off Manufacturer's Suggested Retail Prices (MSRP) for all vehicle options available in your data book or pricing guides.

***Discount off MSRP for all Data Book or Pricing Guide Options: - % Discount \_\_\_\_\_***

**Delivery will be made approximately \_\_\_\_\_ days after receipt of order.**

**ITEM # 2 - New standard equipped 2015 Compact 4 X 2 Crew Cab**

**ACCEPTABLE MAKES AND MODELS:**

Chevrolet Colorado / GMC Canyon

**All units must contain the following options:**

1. Standard 2.5 Liter minimum gasoline engine (Size \_\_\_\_\_ Horsepower \_\_\_\_\_)
2. Manufacturer's standard rear end axle ratio (Ratio: \_\_\_\_\_)
3. Automatic transmission (Speeds \_\_\_\_\_)
4. Air conditioning
5. LH & RH exterior mirrors
6. Tires: (4) manufacturer's standard all season, plus compact spare wheel and tire (Size) \_\_\_\_\_
7. Rubber flooring
8. Minimum 5,500 lbs. GVWR
9. Bed: Minimum 6 Feet
10. Brakes, 4 wheel anti-lock braking system (ABS)
11. Speed control and tilt wheel
12. Cloth seats
13. 3 sets of keys

**DEALER COMPLETE IN DETAIL:**

2015 MAKE \_\_\_\_\_ MODEL \_\_\_\_\_ GVWR \_\_\_\_\_ EACH \$ \_\_\_\_\_

GAS MPG: CITY \_\_\_\_\_ HWY \_\_\_\_\_ FUEL CAPACITY \_\_\_\_\_ OIL CAPACITY \_\_\_\_\_

IS THIS ENGINE E-85 COMPATIBLE? \_\_\_\_\_ IF SO WHAT IS E-85 MPG: CITY \_\_\_\_\_ HWY \_\_\_\_\_

BUMPER TO BUMPER WARRANTY \_\_\_\_\_

POWERTRAIN WARRANTY \_\_\_\_\_

EXTENDED WARRANTY \_\_\_\_\_

**OPTIONAL EQUIPMENT PRICES, Item # 2**

Indicate the additional cost or deduction for the below listed options. Price should include all required options and special equipment.

**Option 2A. Towing Package: Manufacturer's Standard to include frame hitch / receiver and 7 pin trailer wiring connection**

EACH \$ \_\_\_\_\_

**Option 2B. Exterior color to be Federal Standard #595B "Highway Yellow"**

EACH \$ \_\_\_\_\_

**Option 2C. Alternate V6 Gas Engine (state size and horsepower) E-85 compatible? \_\_\_\_\_**

EACH \$ \_\_\_\_\_ SIZE \_\_\_\_\_ HORSEPOWER \_\_\_\_\_

**Option 2D. 2 Full-length factory cab steps or running boards (One on Drivers Side, one on Passenger side)**

SET \$ \_\_\_\_\_

**Option 2E. Power Windows and Door Locks**

EACH \$ \_\_\_\_\_

**OPTIONAL EQUIPMENT PRICES, Item # 2 continued**

- Option 2F.      Optional Rear Axle Ratio      Axle Ratio \_\_\_\_\_**  
**EACH \$ \_\_\_\_\_**
- Option 2G.      Limited Slip Rear Axle      Axle Ratio \_\_\_\_\_**  
**EACH \$ \_\_\_\_\_**
- Option 2H.      LT. 6 ply tires in lieu of 4 ply standard tires      Size \_\_\_\_\_**  
**EACH \$ \_\_\_\_\_**
- Option 2I.      Bluetooth Capability**  
**EACH \$ \_\_\_\_\_**

**Please submit a complete parts list with detailed pricing information for each make/model your company would be willing to provide.** Please indicate below the percent (%) discount off Manufacturer's Suggested Retail Prices (MSRP) for all vehicle options available in your data book or pricing guides.

***Discount off MSRP for all Data Book or Pricing Guide Options: - % Discount \_\_\_\_\_***

**Delivery will be made approximately \_\_\_\_\_ days after receipt of order.**

**ITEM # 3 - New standard equipped 2015 Compact 4 X 4 Extended Cab**

**ACCEPTABLE MAKES AND MODELS:**

Chevrolet Colorado / GMC Canyon

**All units must contain the following options:**

1. Standard 2.5 Liter minimum gasoline engine (Size \_\_\_\_\_ Horsepower \_\_\_\_\_)
2. Manufacturer's standard rear end axle ratio (Ratio: \_\_\_\_\_)
3. Automatic transmission (Speeds \_\_\_\_\_)
4. Air conditioning
5. LH & RH exterior mirrors
6. Tires: (4) manufacturer's standard all season, plus compact spare wheel and tire (Size) \_\_\_\_\_
7. Rubber flooring
8. Minimum 5,700 lbs. GVWR
9. Bed: Minimum 6 Feet
10. Brakes, 4 wheel anti-lock braking system (ABS)
11. Speed control and tilt wheel
12. Cloth seats
13. 3 sets of keys

**DEALER COMPLETE IN DETAIL:**

2015 MAKE \_\_\_\_\_ MODEL \_\_\_\_\_ GVWR \_\_\_\_\_ EACH \$ \_\_\_\_\_

GAS MPG: CITY \_\_\_\_\_ HWY \_\_\_\_\_ FUEL CAPACITY \_\_\_\_\_ OIL CAPACITY \_\_\_\_\_

IS THIS ENGINE E-85 COMPATIBLE? \_\_\_\_\_ IF SO WHAT IS E-85 MPG: CITY \_\_\_\_\_ HWY \_\_\_\_\_

BUMPER TO BUMPER WARRANTY \_\_\_\_\_

POWERTRAIN WARRANTY \_\_\_\_\_

EXTENDED WARRANTY \_\_\_\_\_

**OPTIONAL EQUIPMENT PRICES, Item # 3**

Indicate the additional cost or deduction for the below listed options. Price should include all required options and special equipment.

**Option 3A. Towing Package: Manufacturer's Standard to include frame hitch / receiver and 7 pin trailer wiring connection**

EACH \$ \_\_\_\_\_

**Option 3B. Exterior color to be Federal Standard #595B "Highway Yellow"**

EACH \$ \_\_\_\_\_

**Option 3C. Alternate V6 Gas Engine (state size and horsepower) E-85 compatible? \_\_\_\_\_**

EACH \$ \_\_\_\_\_ SIZE \_\_\_\_\_ HORSEPOWER \_\_\_\_\_

**Option 3D. 2 Full-length factory cab steps or running boards (One on Drivers Side, one on Passenger side)**

SET \$ \_\_\_\_\_

**Option 3E. Power Windows and Door Locks**

EACH \$ \_\_\_\_\_

**OPTIONAL EQUIPMENT PRICES, Item # 3 continued**

**Option 3F.      Optional Rear Axle Ratio      Axle Ratio \_\_\_\_\_**  
**EACH \$ \_\_\_\_\_**

**Option 3G.      Limited Slip Rear Axle      Axle Ratio \_\_\_\_\_**  
**EACH \$ \_\_\_\_\_**

**Option 3H.      LT. 6 ply tires in lieu of 4 ply standard tires      Size \_\_\_\_\_**  
**EACH \$ \_\_\_\_\_**

**Option 3I.      Bluetooth Capability**  
**EACH \$ \_\_\_\_\_**

**Please submit a complete parts list with detailed pricing information for each make/model your company would be willing to provide. Please indicate below the percent (%) discount off Manufacturer's Suggested Retail Prices (MSRP) for all vehicle options available in your data book or pricing guides.**

***Discount off MSRP for all Data Book or Pricing Guide Options: - % Discount \_\_\_\_\_***

**Delivery will be made approximately \_\_\_\_\_ days after receipt of order.**

**ITEM # 4 - New standard equipped 2015 Compact 4 X 4 Crew Cab**

**ACCEPTABLE MAKES AND MODELS:**

Chevrolet Colorado / GMC Canyon

**All units must contain the following options:**

1. Standard 2.5 Liter minimum gasoline engine (Size \_\_\_\_\_ Horsepower \_\_\_\_\_)
2. Manufacturer's standard rear end axle ratio (Ratio: \_\_\_\_\_)
3. Automatic transmission (Speeds \_\_\_\_\_)
4. Air conditioning
5. LH & RH exterior mirrors
6. Tires: (4) manufacturer's standard all season, plus compact spare wheel and tire (Size) \_\_\_\_\_
7. Rubber flooring
8. Minimum 5,800 lbs. GVWR
9. Bed: Minimum 6 Feet
10. Brakes, 4 wheel anti-lock braking system (ABS)
11. Speed control and tilt wheel
12. Cloth seats
13. 3 sets of keys

**DEALER COMPLETE IN DETAIL:**

2015 MAKE \_\_\_\_\_ MODEL \_\_\_\_\_ GVWR \_\_\_\_\_ EACH \$ \_\_\_\_\_

GAS MPG: CITY \_\_\_\_\_ HWY \_\_\_\_\_ FUEL CAPACITY \_\_\_\_\_ OIL CAPACITY \_\_\_\_\_

IS THIS ENGINE E-85 COMPATIBLE? \_\_\_\_\_ IF SO WHAT IS E-85 MPG: CITY \_\_\_\_\_ HWY \_\_\_\_\_

BUMPER TO BUMPER WARRANTY \_\_\_\_\_

POWERTRAIN WARRANTY \_\_\_\_\_

EXTENDED WARRANTY \_\_\_\_\_

**OPTIONAL EQUIPMENT PRICES, Item # 4**

Indicate the additional cost or deduction for the below listed options. Price should include all required options and special equipment.

**Option 4A. Towing Package: Manufacturer's Standard to include frame hitch / receiver and 7 pin trailer wiring connection**

EACH \$ \_\_\_\_\_

**Option 4B. Exterior color to be Federal Standard #595B "Highway Yellow"**

EACH \$ \_\_\_\_\_

**Option 4C. Alternate V6 Gas Engine (state size and horsepower) E-85 compatible? \_\_\_\_\_**

EACH \$ \_\_\_\_\_ SIZE \_\_\_\_\_ HORSEPOWER \_\_\_\_\_

**Option 4D. 2 Full-length factory cab steps or running boards (One on Drivers Side, one on Passenger side)**

SET \$ \_\_\_\_\_

**Option 4E. Power Windows and Door Locks**

EACH \$ \_\_\_\_\_

**OPTIONAL EQUIPMENT PRICES, Item # 4 continued**

**Option 4F. Optional Rear Axle Ratio      Axle Ratio \_\_\_\_\_**

**EACH \$ \_\_\_\_\_**

**Option 4G. Limited Slip Rear Axle      Axle Ratio \_\_\_\_\_**

**EACH \$ \_\_\_\_\_**

**Option 4H. LT. 6 ply tires in lieu of 4 ply standard tires      Size \_\_\_\_\_**

**EACH \$ \_\_\_\_\_**

**Option 4I. Bluetooth Capability**

**EACH \$ \_\_\_\_\_**

**Please submit a complete parts list with detailed pricing information for each make/model your company would be willing to provide.** Please indicate below the percent (%) discount off Manufacturer's Suggested Retail Prices (MSRP) for all vehicle options available in your data book or pricing guides.

***Discount off MSRP for all Data Book or Pricing Guide Options: - % Discount \_\_\_\_\_***

**Delivery will be made approximately \_\_\_\_\_ days after receipt of order.**

**ITEM # 5 - New standard equipped 2015 Half-Ton 4 X 2 Regular Cab Pickup Truck**

**ACCEPTABLE MAKES AND MODELS:**

Standard Ford F-150  
Standard Chevrolet 1500 Silverado/GMC 1500 Sierra  
Standard Dodge Ram 1500

**All units must contain the following options:**

1. Standard minimum V6 gas engine (Liters \_\_\_\_\_ Horsepower \_\_\_\_\_)
2. Manufacturer's standard rear end axle ratio (Ratio: \_\_\_\_\_)
3. Automatic transmission (Speeds \_\_\_\_\_)
4. Air conditioning
5. LH & RH exterior mirrors
6. Tires:(4) manufacturer's standard all season, plus full size spare and wheel (Size)\_\_\_\_\_
7. Rubber flooring
8. Minimum GVWR 6,000 lbs.
9. Long Bed – 8ft.
10. Brakes, 4-wheel anti-lock braking system (ABS)
11. Speed control and tilt wheel
12. Vinyl seats
13. 3 sets of keys

**DEALER COMPLETE IN DETAIL:**

2015 MAKE \_\_\_\_\_ MODEL \_\_\_\_\_ GVWR \_\_\_\_\_ EACH \$ \_\_\_\_\_

GAS MPG: CITY \_\_\_\_\_ HWY \_\_\_\_\_ FUEL CAPACITY \_\_\_\_\_ OIL CAPACITY \_\_\_\_\_

IS THIS ENGINE E-85 COMPATIBLE? \_\_\_\_\_ IF SO WHAT IS E-85 MPG: CITY \_\_\_\_\_ HWY \_\_\_\_\_

BUMPER TO BUMPER WARRANTY \_\_\_\_\_

POWERTRAIN WARRANTY \_\_\_\_\_

EXTENDED WARRANTY \_\_\_\_\_

**OPTIONAL EQUIPMENT PRICES, Item # 5**

Indicate the additional cost or deduction for the below listed options. Price should include all required options and special equipment.

**Option 5A. Towing Package: Manufacturer's Standard to include heavy duty engine oil and transmission cooling systems, Class III frame hitch / receiver and 7 pin trailer wiring connection**

EACH \$ \_\_\_\_\_

**Option 5B. Factory installed Integrated Brake Control**

EACH \$ \_\_\_\_\_

**Option 5C. Exterior color to be Federal Standard #595B "Highway Yellow"**

EACH \$ \_\_\_\_\_

**Option 5D. Alternate larger V8 gasoline engine (state size and horsepower) E-85 compatible? \_\_\_\_\_**

EACH \$ \_\_\_\_\_ SIZE \_\_\_\_\_ HORSEPOWER \_\_\_\_\_



**OPTIONAL EQUIPMENT PRICES, Item #5 continued**

- Option 5E.**    **Alternate diesel engine (state size and horsepower)            B-20 compatible? \_\_\_\_\_**  
EACH \$ \_\_\_\_\_            SIZE \_\_\_\_\_            HORSEPOWER \_\_\_\_\_  
DEF TANK SIZE \_\_\_\_\_            FREQUENCY TO REFILL TANK \_\_\_\_\_
- Option 5F.**    **Optional CNG/LP Package (state engine size and horsepower)**  
EACH \$ \_\_\_\_\_            SIZE \_\_\_\_\_            HORSEPOWER \_\_\_\_\_  
CNG TANK:    GGE CAPACITY \_\_\_\_\_ TANK LOCATION \_\_\_\_\_
- Option 5G.**    **2 Full-length cab steps or running boards. (One on Drivers Side, one on Passenger side.)**  
SET \$ \_\_\_\_\_
- Option 5H.**    **Power Windows and Door Locks**  
EACH \$ \_\_\_\_\_
- Option 5I.**    **Short Bed in lieu of 8' bed**  
EACH \$ \_\_\_\_\_            State size \_\_\_\_\_
- Option 5J.**    **Optional Rear Axle Ratio            Axle Ratio \_\_\_\_\_**  
EACH \$ \_\_\_\_\_
- Option 5K.**    **Limited Slip Rear Axle            Axle Ratio \_\_\_\_\_**  
EACH \$ \_\_\_\_\_
- Option 5L.**    **LT. 6 ply tires in lieu of 4 ply standard tires            Size \_\_\_\_\_**  
EACH \$ \_\_\_\_\_
- Option 5M.**    **10 ply tires in lieu of 4 ply standard tires            Size \_\_\_\_\_**  
EACH \$ \_\_\_\_\_
- Option 5N.**    **Trailer type exterior mirrors in lieu of standard**  
EACH \$ \_\_\_\_\_
- Option 5O.**    **Bluetooth Capability**  
EACH \$ \_\_\_\_\_

Please indicate below the percent (%) discount off Manufacturer's Suggested Retail Prices (MSRP) for all vehicle options available in your data book or pricing guides.

*Discount off MSRP for all Data Book or Pricing Guide Options: - % Discount \_\_\_\_\_*

Delivery will be made approximately \_\_\_\_\_ days after receipt of order.

**ITEM # 6 - New standard equipped 2015 Half-Ton 4 X 2 Extended Cab Pickup Truck**

**ACCEPTABLE MAKES AND MODELS:**

Standard Ford F-150  
Standard Chevrolet 1500 Silverado/GMC 1500 Sierra  
Standard Dodge Ram 1500

**All units must contain the following options:**

1. Standard minimum V6 gas engine (Liters \_\_\_\_\_ Horsepower \_\_\_\_\_)
2. Manufacturer's standard rear end axle ratio (Ratio: \_\_\_\_\_)
3. Automatic transmission (Speeds \_\_\_\_\_)
4. Air conditioning
5. LH & RH exterior mirrors
6. Tires:(4) manufacturer's standard all season, plus full size spare and wheel (Size)\_\_\_\_\_
7. Rubber flooring
8. Minimum GVWR 6,000 lbs.
9. Long Bed – 8ft.
10. Brakes, 4-wheel anti-lock braking system (ABS)
11. Speed control and tilt wheel
12. Vinyl seats
13. 3 sets of keys

**DEALER COMPLETE IN DETAIL:**

2015 MAKE \_\_\_\_\_ MODEL \_\_\_\_\_ GVWR \_\_\_\_\_ EACH \$ \_\_\_\_\_

GAS MPG: CITY \_\_\_\_\_ HWY \_\_\_\_\_ FUEL CAPACITY \_\_\_\_\_ OIL CAPACITY \_\_\_\_\_

IS THIS ENGINE E-85 COMPATIBLE? \_\_\_\_\_ IF SO WHAT IS E-85 MPG: CITY \_\_\_\_\_ HWY \_\_\_\_\_

BUMPER TO BUMPER WARRANTY \_\_\_\_\_

POWERTRAIN WARRANTY \_\_\_\_\_

EXTENDED WARRANTY \_\_\_\_\_

**OPTIONAL EQUIPMENT PRICES, Item #6**

Indicate the additional cost or deduction for the below listed options. Price should include all required options and special equipment.

Option 6A. Towing Package: Manufacturer's Standard to include heavy duty engine oil and transmission cooling systems, Class III frame hitch / receiver and 7 pin trailer wiring connection  
EACH \$ \_\_\_\_\_

Option 6B. Factory installed Integrated Brake Control  
EACH \$ \_\_\_\_\_

Option 6C. Exterior color to be Federal Standard #595B "Highway Yellow"  
EACH \$ \_\_\_\_\_

Option 6D. Alternate larger V8 gasoline engine (state size and horsepower) E-85 compatible? \_\_\_\_\_  
EACH \$ \_\_\_\_\_ SIZE \_\_\_\_\_ HORSEPOWER \_\_\_\_\_

**OPTIONAL EQUIPMENT PRICES, Item #6 continued**

- Option 6E.**    **Alternate diesel engine (state size and horsepower)**                      **B-20 compatible? \_\_\_\_\_**  
EACH \$ \_\_\_\_\_                      **SIZE** \_\_\_\_\_                      **HORSEPOWER** \_\_\_\_\_  
**DEF TANK SIZE** \_\_\_\_\_                      **FREQUENCY TO REFILL TANK** \_\_\_\_\_
- Option 6F.**    **Optional CNG/LP Package (state engine size and horsepower)**  
EACH \$ \_\_\_\_\_                      **SIZE** \_\_\_\_\_                      **HORSEPOWER** \_\_\_\_\_  
**CNG TANK: GGE CAPACITY** \_\_\_\_\_ **TANK LOCATION** \_\_\_\_\_
- Option 6G.**    **2 Full-length cab steps or running boards. (One on Drivers Side, one on Passenger side.)**  
SET \$ \_\_\_\_\_
- Option 6H.**    **Power Windows and Door Locks**  
EACH \$ \_\_\_\_\_
- Option 6I.**    **Short Bed in lieu of 8' bed**  
EACH \$ \_\_\_\_\_                      **State Size** \_\_\_\_\_
- Option 6J.**    **Optional Rear Axle Ratio**                      **Axle Ratio** \_\_\_\_\_  
EACH \$ \_\_\_\_\_
- Option 6K.**    **Limited Slip Rear Axle**                      **Axle Ratio** \_\_\_\_\_  
EACH \$ \_\_\_\_\_
- Option 6L.**    **LT. 6 ply tires in lieu of 4 ply standard tires**                      **Size** \_\_\_\_\_  
EACH \$ \_\_\_\_\_
- Option 6M.**    **10 ply tires in lieu of 4 ply standard tires**                      **Size** \_\_\_\_\_  
EACH \$ \_\_\_\_\_
- Option 6N.**    **Trailer type exterior mirrors in lieu of standard**  
EACH \$ \_\_\_\_\_
- Option 6O.**    **Bluetooth Capability**  
EACH \$ \_\_\_\_\_

Please indicate below the percent (%) discount off Manufacturer's Suggested Retail Prices (MSRP) for all vehicle options available in your data book or pricing guides.

*Discount off MSRP for all Data Book or Pricing Guide Options: - % Discount* \_\_\_\_\_

Delivery will be made approximately \_\_\_\_\_ days after receipt of order.

**ITEM # 7 - New standard equipped 2015 Half-Ton 4 X 2 Crew Cab Pickup Truck**

**ACCEPTABLE MAKES AND MODELS:**

Standard Ford F-150  
Standard Chevrolet 1500 Silverado/GMC Sierra  
Standard Dodge Ram 1500

**All units must contain the following options:**

1. Standard minimum V6 gas engine (Liters \_\_\_\_\_ Horsepower \_\_\_\_\_)
2. Manufacturer's standard rear end axle ratio (Ratio: \_\_\_\_\_)
3. Automatic transmission (Speeds \_\_\_\_\_)
4. Air conditioning
5. LH & RH exterior mirrors
6. Tires:(4) manufacturer's standard all season, plus full size spare and wheel (Size) \_\_\_\_\_
7. Rubber flooring
8. Minimum GVWR 6,000 lbs.
9. Long Bed – 5 ½ ft.
10. Brakes, 4-wheel anti-lock braking system (ABS)
11. Speed control and tilt wheel
12. Vinyl seats
13. 3 sets of keys

**DEALER COMPLETE IN DETAIL:**

2015 MAKE \_\_\_\_\_ MODEL \_\_\_\_\_ GVWR \_\_\_\_\_ EACH \$ \_\_\_\_\_

GAS MPG: CITY \_\_\_\_\_ HWY \_\_\_\_\_ FUEL CAPACITY \_\_\_\_\_ OIL CAPACITY \_\_\_\_\_

IS THIS ENGINE E-85 COMPATIBLE? \_\_\_\_\_ IF SO WHAT IS E-85 MPG: CITY \_\_\_\_\_ HWY \_\_\_\_\_

BUMPER TO BUMPER WARRANTY \_\_\_\_\_

POWERTRAIN WARRANTY \_\_\_\_\_

EXTENDED WARRANTY \_\_\_\_\_

**OPTIONAL EQUIPMENT PRICES, Item # 7**

Indicate the additional cost or deduction for the below listed options. Price should include all required options and special equipment.

**Option 7A. Towing Package: Manufacturer's Standard to include heavy duty engine oil and transmission cooling systems, Class III frame hitch / receiver and 7 pin trailer wiring connection**

EACH \$ \_\_\_\_\_

**Option 7B. Factory installed Integrated Brake Control**

EACH \$ \_\_\_\_\_

**Option 7C. Exterior color to be Federal Standard #595B "Highway Yellow"**

EACH \$ \_\_\_\_\_

**Option 7D. Alternate larger V8 gasoline engine (state size and horsepower) E-85 compatible? \_\_\_\_\_**

EACH \$ \_\_\_\_\_ SIZE \_\_\_\_\_ HORSEPOWER \_\_\_\_\_



**ITEM # 8 - New standard equipped 2015 Half-Ton 4 X 4, Regular Cab Pickup Truck**

**ACCEPTABLE MAKES AND MODELS:**

Standard Ford F-150  
Standard Chevrolet Silverado1500/GMC Sierra  
Standard Dodge Ram 1500

**All units must contain the following options:**

1. Standard minimum V6 gas engine (Liters \_\_\_\_\_ Horsepower \_\_\_\_\_)
2. Manufacturer's standard rear end axle ratio (Ratio: \_\_\_\_\_)
3. Automatic transmission (Speeds \_\_\_\_\_)
4. Air conditioning
5. LH & RH exterior mirrors
6. Tires:(4) manufacturer's standard all season, plus full size spare and wheel (Size) \_\_\_\_\_
7. Rubber flooring
8. Minimum GVWR 6000 lbs.
9. Auto locking hubs
10. Brakes 4-wheel anti-lock braking system (ABS)
11. Speed control and tilt wheel
12. Long bed 8ft.
13. Vinyl seats
14. 3 sets of keys

**DEALER COMPLETE IN DETAIL:**

2015 MAKE \_\_\_\_\_ MODEL \_\_\_\_\_ GVWR \_\_\_\_\_ EACH \$ \_\_\_\_\_

GAS MPG: CITY \_\_\_\_\_ HWY \_\_\_\_\_ FUEL CAPACITY \_\_\_\_\_ OIL CAPACITY \_\_\_\_\_

IS THIS ENGINE E-85 COMPATIBLE? \_\_\_\_\_ IF SO WHAT IS E-85 MPG: CITY \_\_\_\_\_ HWY \_\_\_\_\_

BUMPER TO BUMPER WARRANTY \_\_\_\_\_

POWERTRAIN WARRANTY \_\_\_\_\_

EXTENDED WARRANTY \_\_\_\_\_

**OPTIONAL EQUIPMENT PRICES, Item # 8**

Indicate the additional cost or deduction for the below listed options. Price should include all required options and special equipment.

**Option 8A. Towing Package: Manufacturer's Standard to include heavy duty engine oil, and transmission cooling systems, Class III frame hitch / receiver and 7 pin trailer wiring connection**  
EACH \$ \_\_\_\_\_

**Option 8B. Factory installed Integrated Brake Control**  
EACH \$ \_\_\_\_\_

**Option 8C. Exterior color to be Federal Standard #595B "Highway Yellow"**  
EACH \$ \_\_\_\_\_

**Option 8D. Alternate larger V8 gasoline engine (state size and horsepower) E-85 compatible? \_\_\_\_\_**  
EACH \$ \_\_\_\_\_ SIZE \_\_\_\_\_ HORSEPOWER \_\_\_\_\_

**OPTIONAL EQUIPMENT PRICES, Item # 8 continued**

- Option 8E.**     **Alternate diesel engine (state size and horsepower)**     **B-20 compatible? \_\_\_\_\_**  
EACH \$ \_\_\_\_\_     **SIZE** \_\_\_\_\_     **HORSEPOWER** \_\_\_\_\_  
DEF TANK SIZE \_\_\_\_\_     **FREQUENCY TO REFILL TANK** \_\_\_\_\_
- Option 8F.**     **Optional CNG/LP Package (state engine size and horsepower)**  
EACH \$ \_\_\_\_\_     **SIZE** \_\_\_\_\_     **HORSEPOWER** \_\_\_\_\_  
CNG TANK:     **GGE CAPACITY** \_\_\_\_\_     **TANK LOCATION** \_\_\_\_\_
- Option 8G.**     **2 Full-length cab steps or running boards (One on Drivers Side, one on Passenger side)**  
SET \$ \_\_\_\_\_
- Option 8H.**     **Power Window and Door locks**  
EACH \$ \_\_\_\_\_
- Option 8I.**     **Short Bed in lieu of the 8' Bed**  
EACH \$ \_\_\_\_\_     **State size** \_\_\_\_\_
- Option 8J.**     **Optional Rear Axle Ratio**     **Axle Ratio** \_\_\_\_\_  
EACH \$ \_\_\_\_\_
- Option 8K.**     **Limited Slip Rear Axle.**     **Axle Ratio** \_\_\_\_\_  
EACH \$ \_\_\_\_\_
- Option 8L.**     **LT. 6 ply. tires in lieu of 4 ply. standard tires**     **Size** \_\_\_\_\_  
EACH \$ \_\_\_\_\_
- Option 8M.**     **10 ply tires in lieu of 4 ply standard tires**     **Size** \_\_\_\_\_  
EACH \$ \_\_\_\_\_
- Option 8N.**     **Trailer type exterior mirrors in lieu of standard**  
EACH \$ \_\_\_\_\_
- Option 8O.**     **Bluetooth Capability**  
EACH \$ \_\_\_\_\_

**Please indicate below the percent (%) discount off Manufacturer's Suggested Retail Prices (MSRP) for all vehicle options available in your data book or pricing guides.**

***Discount off MSRP for all Data Book or Pricing Guide Options: - % Discount*** \_\_\_\_\_

**Delivery will be made approximately \_\_\_\_\_ days after receipt of order.**

**ITEM # 9 - New standard equipped 2015 Half-Ton 4 X 4 Extended Cab Pickup Truck**

**ACCEPTABLE MAKES AND MODELS:**

Standard Ford F-150  
Standard Chevrolet 1500 Silverado/GMC Sierra  
Standard Dodge Ram 1500

**All units must contain the following options:**

1. Standard minimum V6 gas engine (Liters \_\_\_\_\_ Horsepower \_\_\_\_\_)
2. Manufacturer's standard rear end axle ratio (Ratio: \_\_\_\_\_)
3. Automatic transmission (Speeds \_\_\_\_\_)
4. Air conditioning
5. LH & RH exterior mirrors
6. Tires:(4) manufacturer's standard all season, plus full size spare and wheel (Size) \_\_\_\_\_
7. Rubber flooring
8. Minimum GVWR 6,000 lbs.
9. Long Bed – 8ft.
10. Brakes, 4-wheel anti-lock braking system (ABS)
11. Speed control and tilt wheel
12. Vinyl seats
13. 3 sets of keys

**DEALER COMPLETE IN DETAIL:**

2015 MAKE \_\_\_\_\_ MODEL \_\_\_\_\_ GVWR \_\_\_\_\_ EACH \$ \_\_\_\_\_

GAS MPG: CITY \_\_\_\_\_ HWY \_\_\_\_\_ FUEL CAPACITY \_\_\_\_\_ OIL CAPACITY \_\_\_\_\_

IS THIS ENGINE E-85 COMPATIBLE? \_\_\_\_\_ IF SO WHAT IS E-85 MPG: CITY \_\_\_\_\_ HWY \_\_\_\_\_

BUMPER TO BUMPER WARRANTY \_\_\_\_\_

POWERTRAIN WARRANTY \_\_\_\_\_

EXTENDED WARRANTY \_\_\_\_\_

**OPTIONAL EQUIPMENT PRICES, Item # 9**

Indicate the additional cost or deduction for the below listed options. Price should include all required options and special equipment.

**Option 9A. Towing Package: Manufacturer's Standard to include heavy duty engine oil and transmission cooling systems, Class III frame hitch / receiver and 7 pin trailer wiring connection**

EACH \$ \_\_\_\_\_

**Option 9B. Factory installed Integrated Brake Control**

EACH \$ \_\_\_\_\_

**Option 9C. Exterior color to be Federal Standard #595B "Highway Yellow"**

EACH \$ \_\_\_\_\_

**Option 9D. Alternate larger V8 gasoline engine (state size and horsepower) E-85 compatible? \_\_\_\_\_**

EACH \$ \_\_\_\_\_ SIZE \_\_\_\_\_ HORSEPOWER \_\_\_\_\_





**ITEM # 10 - New standard equipped 2015 Half-Ton 4 X 4 Crew Cab Pickup Truck**

**ACCEPTABLE MAKES AND MODELS:**

Standard Ford F-150  
Standard Chevrolet 1500 Silverado/GMC Sierra  
Standard Dodge Ram 1500

**All units must contain the following options:**

1. Standard minimum V6 gas engine (Liters \_\_\_\_\_ Horsepower \_\_\_\_\_)
2. Manufacturer's standard rear end axle ratio (Ratio: \_\_\_\_\_)
3. Automatic transmission (Speeds \_\_\_\_\_)
4. Air conditioning
5. LH & RH exterior mirrors
6. Tires:(4) manufacturer's standard all season, plus full size spare and wheel (Size) \_\_\_\_\_
7. Rubber flooring
8. Minimum GVWR 6,000 lbs.
9. Long Bed – 5 ½ ft.
10. Brakes, 4-wheel anti-lock braking system (ABS)
11. Speed control and tilt wheel
12. Vinyl seats
13. 3 sets of keys

**DEALER COMPLETE IN DETAIL:**

2015 MAKE \_\_\_\_\_ MODEL \_\_\_\_\_ GVWR \_\_\_\_\_ EACH \$ \_\_\_\_\_  
GAS MPG: CITY \_\_\_\_\_ HWY \_\_\_\_\_ FUEL CAPACITY \_\_\_\_\_ OIL CAPACITY \_\_\_\_\_  
IS THIS ENGINE E-85 COMPATIBLE? \_\_\_\_\_ IF SO WHAT IS E-85 MPG: CITY \_\_\_\_\_ HWY \_\_\_\_\_  
BUMPER TO BUMPER WARRANTY \_\_\_\_\_  
POWERTRAIN WARRANTY \_\_\_\_\_  
EXTENDED WARRANTY \_\_\_\_\_

**OPTIONAL EQUIPMENT PRICES, Item # 10**

Indicate the additional cost or deduction for the below listed options. Price should include all required options and special equipment.

- Option 10A. Towing Package: Manufacturer's Standard to include heavy duty engine oil and transmission cooling systems, Class III frame hitch / receiver and 7 pin trailer wiring connection**  
EACH \$ \_\_\_\_\_
- Option 10B. Factory installed Integrated Brake Control**  
EACH \$ \_\_\_\_\_
- Option 10C. Exterior color to be Federal Standard #595B "Highway Yellow"**  
EACH \$ \_\_\_\_\_
- Option 10D. Alternate larger V8 gasoline engine (state size and horsepower) E-85 compatible? \_\_\_\_\_**  
EACH \$ \_\_\_\_\_ SIZE \_\_\_\_\_ HORSEPOWER \_\_\_\_\_



**ITEM # 11 - New standard equipped 2015 (Compact) Sport Utility Vehicle 2WD**

**ACCEPTABLE MAKES AND MODELS:**

Standard Ford Escape

Standard Jeep Patriot and Jeep Compass

Standard Chevrolet Equinox / GMC Terrain

**All units must contain the following options:**

1. Standard, 1.6L Turbo, 4 cylinder or 2.0L 4 cylinder minimum Gas Engine (**Specify**) (Size \_\_\_\_\_ Horsepower \_\_\_\_\_)
2. Manufacturer's standard rear end axle ratio (Ratio: \_\_\_\_\_)
3. 4-speed automatic transmission
4. Air conditioning
5. LH & RH mirrors
6. Four manufacturer's all-season tires plus manufacturer's standard size spare tire and wheel (Size) \_\_\_\_\_
7. Rubber flooring
8. Brakes 4-wheel anti-lock braking system (ABS)
9. Speed control and tilt wheel
10. Auto locking hubs
11. Wheelbase minimum 103"
12. 3 sets of keys

**DEALER COMPLETE IN DETAIL:**

2015 MAKE \_\_\_\_\_ MODEL \_\_\_\_\_ GVWR \_\_\_\_\_ EACH \$ \_\_\_\_\_

GAS MPG: CITY \_\_\_\_\_ HWY \_\_\_\_\_ FUEL CAPACITY \_\_\_\_\_ OIL CAPACITY \_\_\_\_\_

IS THIS ENGINE E-85 COMPATIBLE? \_\_\_\_\_ IF SO WHAT IS E-85 MPG: CITY \_\_\_\_\_ HWY \_\_\_\_\_

BUMPER TO BUMPER WARRANTY \_\_\_\_\_

POWERTRAIN WARRANTY \_\_\_\_\_

EXTENDED WARRANTY \_\_\_\_\_

**OPTIONAL EQUIPMENT PRICES, Item # 11**

Indicate the additional cost or deduction for the below listed options. Prices should include all required options and special equipment.

Option 11A. Towing Package: Manufacturer's Standard to include heavy duty engine oil and transmission cooling systems, Class III frame hitch / receiver and 4 pin wiring installed plus wiring harness for 7 pin

EACH \$ \_\_\_\_\_

Option 11B. Engine V- 6, minimum 3.0 L or larger E-85 compatible? \_\_\_\_\_

EACH \$ \_\_\_\_\_ SIZE \_\_\_\_\_ HORSEPOWER \_\_\_\_\_

Option 11C. Power Windows and Door Locks

EACH \$ \_\_\_\_\_

Option 11D. Optional Rear Axle Ratio Axle Ratio \_\_\_\_\_

EACH \$ \_\_\_\_\_

Option 11E. Bluetooth Capability

EACH \$ \_\_\_\_\_

Please indicate below the percent (%) discount off Manufacturer's Suggested Retail Prices (MSRP) for all vehicle options available in your data book or pricing guides.

Discount off MSRP for all Data Book or Pricing Guide Options: - % Discount \_\_\_\_\_

Delivery will be made approximately \_\_\_\_\_ days after receipt of order.

**ITEM # 12 - New standard equipped 2015 (Compact) Sport Utility Vehicle 4WD or AWD**

**ACCEPTABLE MAKES AND MODELS:**

Standard Ford Escape  
Standard Jeep Patriot and Jeep Compass  
Standard Chevrolet Equinox / GMC Terrain

**All units must contain the following options:**

1. Standard, 1.6L Turbo, 4 cylinder or 2.0L 4 cylinder minimum Gas Engine (**Specify**) (Size \_\_\_\_\_ Horsepower \_\_\_\_\_)
2. Manufacturer's standard rear end axle ratio (Ratio: \_\_\_\_\_)
3. 4-speed automatic transmission
4. Air conditioning
5. LH & RH mirrors
6. Four manufacturer's all-season tires plus manufacturer's standard size spare tire and wheel (Size) \_\_\_\_\_
7. Rubber flooring
8. Brakes 4-wheel anti-lock braking system (ABS)
9. Speed control and tilt wheel
10. Auto locking hubs
11. Wheelbase minimum 103"
12. 3 sets of keys

**DEALER COMPLETE IN DETAIL:**

**CIRCLE ONE: 4WD    AWD**

**2015 MAKE** \_\_\_\_\_ **MODEL** \_\_\_\_\_ **GVWR** \_\_\_\_\_ **EACH \$** \_\_\_\_\_

**GAS MPG: CITY** \_\_\_\_\_ **HWY** \_\_\_\_\_ **FUEL CAPACITY** \_\_\_\_\_ **OIL CAPACITY** \_\_\_\_\_

**IS THIS ENGINE E-85 COMPATIBLE?** \_\_\_\_\_ **IF SO WHAT IS E-85 MPG: CITY** \_\_\_\_\_ **HWY** \_\_\_\_\_

**BUMPER TO BUMPER WARRANTY** \_\_\_\_\_

**POWERTRAIN WARRANTY** \_\_\_\_\_

**EXTENDED WARRANTY** \_\_\_\_\_

**OPTIONAL EQUIPMENT PRICES, Item # 12**

**Indicate the additional cost or deduction for the below listed options. Prices should include all required options and special equipment.**

**Option 12A. Towing Package: Manufacturer's Standard to include heavy duty engine oil and transmission cooling systems, Class III frame hitch / receiver and 4 pin wiring installed plus wiring harness for 7 pin**

**EACH \$** \_\_\_\_\_

**Option 12B. Engine V- 6, minimum 3.0 L or larger                      E-85 compatible?** \_\_\_\_\_

**EACH \$** \_\_\_\_\_ **SIZE** \_\_\_\_\_ **HORSEPOWER** \_\_\_\_\_

**Option 12C. Power Windows and Door Locks**

**EACH \$** \_\_\_\_\_

**Option 12D. Optional Rear Axle Ratio                      Axle Ratio** \_\_\_\_\_

**EACH \$** \_\_\_\_\_

**Option 12E. Bluetooth Capability**

**EACH \$** \_\_\_\_\_

**Please indicate below the percent (%) discount off Manufacturer's Suggested Retail Prices (MSRP) for all vehicle options available in your data book or pricing guides.**

**Discount off MSRP for all Data Book or Pricing Guide Options: - % Discount** \_\_\_\_\_

**Delivery will be made approximately** \_\_\_\_\_ **days after receipt of order.**

**ITEM # 13 - New standard equipped 2015 (Full Size) Sport Utility Vehicle 2WD**

**ACCEPTABLE MAKES AND MODELS:**

- Standard Ford Explorer
- Standard Ford Expedition
- Standard Chevrolet Tahoe
- Standard Chevrolet Traverse
- Standard Dodge Durango

**All units must contain the following options:**

1. Standard minimum 2.0L Turbo 4 cylinder, 3.6L V6 or 5.3L V8 gasoline engine (**Specify**) (Size \_\_\_\_\_ Horsepower \_\_\_\_\_)
2. Manufacturer's standard rear end axle ratio (Ratio: \_\_\_\_\_)
3. Automatic transmission (Speeds \_\_\_\_\_)
4. LH & RH exterior mirrors
5. Four manufacturer's all-season tires plus manufacturer's standard size spare tire and wheel (Size) \_\_\_\_\_
6. Rubber flooring
7. Brakes 4-wheel anti-lock braking system (ABS)
8. Speed control and tilt wheel
9. Air Condition
10. Wheelbase 113" Minimum
11. 3 sets of keys

**DEALER COMPLETE IN DETAIL:**

2015 MAKE \_\_\_\_\_ MODEL \_\_\_\_\_ GVWR \_\_\_\_\_ EACH \$ \_\_\_\_\_

GAS MPG: CITY \_\_\_\_\_ HWY \_\_\_\_\_

FUEL CAPACITY \_\_\_\_\_ OIL CAPACITY \_\_\_\_\_

IS THIS ENGINE E-85 COMPATIBLE? \_\_\_\_\_ IF SO WHAT IS E-85 MPG: CITY \_\_\_\_\_ HWY \_\_\_\_\_

BUMPER TO BUMPER WARRANTY \_\_\_\_\_

POWERTRAIN WARRANTY \_\_\_\_\_

EXTENDED WARRANTY \_\_\_\_\_

**OPTIONAL EQUIPMENT PRICES, Item # 13**

Indicate the additional cost or deduction for the below listed options. Prices should include all required options and special equipment.

Option 13A. Towing Package: Manufacturer's Standard to include heavy duty engine oil and transmission cooling systems, Class III frame hitch / receiver and 4 pin wiring installed plus wiring harness for 7 pin

EACH \$ \_\_\_\_\_

Option 13B. Power Windows and Door Locks

EACH \$ \_\_\_\_\_

Option 13C. Optional Rear Axle Ratio Axle Ratio \_\_\_\_\_

EACH \$ \_\_\_\_\_

Option 13D. Alternate Gas Engine (Size) \_\_\_\_\_ (Horsepower) \_\_\_\_\_ E-85 compatible? \_\_\_\_\_

EACH \$ \_\_\_\_\_

Option 13E. Bluetooth Capability

EACH \$ \_\_\_\_\_

Please indicate below the percent (%) discount off Manufacturer's Suggested Retail Prices (MSRP) for all vehicle options available in your data book or pricing guides.

Discount off MSRP for all Data Book or Pricing Guide Options: - % Discount \_\_\_\_\_

Delivery will be made approximately \_\_\_\_\_ days after receipt of order.

**ITEM # 14 - New standard equipped 2015 (Full Size) Sport Utility Vehicle 4WD or AWD**

**ACCEPTABLE MAKES AND MODELS:**

Standard Ford Explorer  
Standard Ford Expedition  
Standard Chevrolet Tahoe  
Standard Chevrolet Traverse  
Standard Dodge Durango

**All units must contain the following options:**

1. Standard minimum 3.5L V6, 3.6L V6 or 5.3L V8 gasoline engine (**Specify**) (Size \_\_\_\_\_ Horsepower \_\_\_\_\_)
2. Manufacturer's standard rear end axle ratio (Ratio: \_\_\_\_\_)
3. Automatic transmission (Speeds \_\_\_\_\_)
4. LH & RH exterior mirrors
5. Four manufacturer's all-season tires plus manufacturer's standard size spare tire and wheel (Size) \_\_\_\_\_
6. Rubber flooring
7. Brakes 4-wheel anti-lock braking system (ABS)
8. Speed control and tilt wheel
9. Air Condition
10. Wheelbase 113" Minimum
11. 3 sets of keys

**DEALER COMPLETE IN DETAIL:**

CIRCLE ONE: 4WD    AWD

2015 MAKE \_\_\_\_\_ MODEL \_\_\_\_\_ GVWR \_\_\_\_\_ EACH \$ \_\_\_\_\_

GAS MPG: CITY \_\_\_\_\_ HWY \_\_\_\_\_ FUEL CAPACITY \_\_\_\_\_ OIL CAPACITY \_\_\_\_\_

IS THIS ENGINE E-85 COMPATIBLE? \_\_\_\_\_ IF SO WHAT IS E-85 MPG: CITY \_\_\_\_\_ HWY \_\_\_\_\_

BUMPER TO BUMPER WARRANTY \_\_\_\_\_

POWERTRAIN WARRANTY \_\_\_\_\_

EXTENDED WARRANTY \_\_\_\_\_

**OPTIONAL EQUIPMENT PRICES, Item # 14**

Indicate the additional cost or deduction for the below listed options. Prices should include all required options and special equipment.

Option 14A. Towing Package: Manufacturer's Standard to include heavy duty engine oil and transmission cooling systems, Class III frame hitch / receiver and 4 pin wiring installed plus wiring harness for 7 pin

EACH \$ \_\_\_\_\_

Option 14B. Power Windows and Door Locks

EACH \$ \_\_\_\_\_

Option 14C. Optional Rear Axle Ratio      Axle Ratio \_\_\_\_\_

EACH \$ \_\_\_\_\_

Option 14D. Alternate Gas Engine (Size) \_\_\_\_\_ (Horsepower) \_\_\_\_\_ E-85 compatible? \_\_\_\_\_

EACH \$ \_\_\_\_\_

Option 14E. Bluetooth Capability

EACH \$ \_\_\_\_\_

Please indicate below the percent (%) discount off Manufacturer's Suggested Retail Prices (MSRP) for all vehicle options available in your data book or pricing guides.

Discount off MSRP for all Data Book or Pricing Guide Options: - % Discount \_\_\_\_\_

Delivery will be made approximately \_\_\_\_\_ days after receipt of order.

**ITEM # 15 - New standard equipped 2015 or Newer 2WD Model Carryalls.**

**ACCEPTABLE MAKES AND MODELS:**

Standard Chevrolet Suburban with 130.0" Wheelbase  
Standard GMC Yukon XL with 130.0" Wheelbase  
Standard Ford Expedition EL with 131.0" Wheelbase

**All units bid must contain the following options:**

1. Standard minimum V6 gasoline engine (Size \_\_\_\_\_ Horsepower \_\_\_\_\_)
2. Manufacturer's standard rear end axle ratio (Ratio: \_\_\_\_\_)
3. Automatic Transmission (Speeds \_\_\_\_\_)
4. Front and rear heat/air conditioning
5. LH & RH manual mirrors
6. Tires:(4) manufacturer's standard all season, plus full size spare and wheel (Size \_\_\_\_\_)
7. Rubber flooring
8. Standard seating with second and third row bench seat
9. Minimum GVWR 7,300 lbs.
10. Brakes 4-wheel anti-lock braking system (ABS)
11. Speed control and tilt wheel
12. Cloth seats
13. 3 sets of keys

**DEALER COMPLETE IN DETAIL:**

2015 MAKE \_\_\_\_\_ MODEL \_\_\_\_\_ GVWR \_\_\_\_\_ EACH \$ \_\_\_\_\_

GAS MPG: CITY \_\_\_\_\_ HWY \_\_\_\_\_ FUEL CAPACITY \_\_\_\_\_ OIL CAPACITY \_\_\_\_\_

IS THIS ENGINE E-85 COMPATIBLE? \_\_\_\_\_ IF SO WHAT IS E-85 MPG: CITY \_\_\_\_\_ HWY \_\_\_\_\_

BUMPER TO BUMPER WARRANTY \_\_\_\_\_

POWERTRAIN WARRANTY \_\_\_\_\_

EXTENDED WARRANTY \_\_\_\_\_

**OPTIONAL EQUIPMENT PRICES, Item # 15**

Indicate the additional cost or deduction for the below listed options. Prices should include all required options and special equipment.

Option 15A. Deep tinted windows EACH \$ \_\_\_\_\_

Option 15B. Heavy-duty, Class 4 with a Type III adapter trailer hitch. Special equipment which includes weight distributing hitch platform and wiring harness for a 7 pin commercial truck connector. EACH \$ \_\_\_\_\_

Option 15C. Exterior color to be Federal Standard #595B "Highway Yellow" EACH \$ \_\_\_\_\_

Option 15D. Delete 3<sup>rd</sup> row rear bench seat EACH \$ \_\_\_\_\_ (Deduct)

Option 15E. 2 Full length cab steps or running boards. (One on Drivers Side, one on Passenger side) SET \$ \_\_\_\_\_

Option 15F. Optional Rear Axle Ratio Axle Ratio \_\_\_\_\_ EACH \$ \_\_\_\_\_



**OPTIONAL EQUIPMENT PRICES, Item # 15 continued**

**Option 15G. Limited Slip Rear Axle. Axle Ratio \_\_\_\_\_ EACH \$ \_\_\_\_\_**

**Option 15H. Vinyl seats in lieu of cloth. EACH \$ \_\_\_\_\_**

**Option 15I. Bluetooth Capability EACH \$ \_\_\_\_\_**

Please indicate below the percent (%) discount off Manufacturer's Suggested Retail Prices (MSRP) for all vehicle options available in your data book or pricing guides.

***% discount off MSRP for all Data Book or Pricing Guide Options: - % Discount \_\_\_\_\_***

**Delivery will be made approximately \_\_\_\_\_ days after receipt of order.**

**ITEM # 16 - New standard equipped 2015 or Newer 4WD Model Carryalls.**

**ACCEPTABLE MAKES AND MODELS:**

Standard Chevrolet Suburban with 130.0" Wheelbase

Standard GMC Yukon XL with 130.0" Wheelbase

Standard Ford Expedition EL with 131.0" Wheelbase

**All units bid must contain the following options:**

14. Standard minimum V6 gasoline engine (Size \_\_\_\_\_ Horsepower \_\_\_\_\_)
15. Manufacturer's standard rear end axle ratio (Ratio: \_\_\_\_\_)
16. Automatic Transmission (Speeds \_\_\_\_\_)
17. Front and rear heat/air conditioning
18. LH & RH manual mirrors
19. Tires:(4) manufacturer's standard all season, plus full size spare and wheel (Size \_\_\_\_\_)
20. Rubber flooring
21. Standard seating with second and third row bench seat
22. Minimum GVWR 7,300 lbs.
23. Brakes 4-wheel anti-lock braking system (ABS)
24. Speed control and tilt wheel
25. Cloth seats
26. 3 sets of keys

**DEALER COMPLETE IN DETAIL:**

2015 MAKE \_\_\_\_\_ MODEL \_\_\_\_\_ GVWR \_\_\_\_\_ EACH \$ \_\_\_\_\_

GAS MPG: CITY \_\_\_\_\_ HWY \_\_\_\_\_ FUEL CAPACITY \_\_\_\_\_ OIL CAPACITY \_\_\_\_\_

IS THIS ENGINE E-85 COMPATIBLE? \_\_\_\_\_ IF SO WHAT IS E-85 MPG: CITY \_\_\_\_\_ HWY \_\_\_\_\_

BUMPER TO BUMPER WARRANTY \_\_\_\_\_

POWERTRAIN WARRANTY \_\_\_\_\_

EXTENDED WARRANTY \_\_\_\_\_

**OPTIONAL EQUIPMENT PRICES, Item # 16**

Indicate the additional cost or deduction for the below listed options. Prices should include all required options and special equipment.

Option 16A. Deep tinted windows EACH \$ \_\_\_\_\_

Option 16B. Heavy-duty, Class 4 with a Type III adapter trailer hitch. Special equipment which includes weight distributing hitch platform and wiring harness for a 7 pin commercial truck connector. EACH \$ \_\_\_\_\_

Option 16C. Exterior color to be Federal Standard #595B "Highway Yellow" EACH \$ \_\_\_\_\_

Option 16D. Delete 3<sup>rd</sup> row rear bench seat EACH \$ \_\_\_\_\_ (Deduct)



**Item #17– New standard equipped 2015 7- Passenger Extended Mini-Van, Alternative Fuel**

**ACCEPTABLE MAKES AND MODELS:**

Standard Chrysler Town and Country  
Standard Dodge Grand Caravan

**All units must contain the following options:**

1. Standard minimum 3.3 L 6 cylinder Flex Fuel E-85 engine (Size \_\_\_\_\_ Horsepower \_\_\_\_\_)
2. Automatic transmission (Speeds \_\_\_\_\_)
3. Factory installed front and rear heat/air conditioning
4. LH & RH mirrors
5. Four manufacturer's all-season tires plus manufacturer's standard size spare tire and wheel (Size) \_\_\_\_\_
6. 4 wheel anti-lock braking system (ABS)
7. Speed control and tilt wheel
8. Wheelbases 119" Minimum
9. Rubber floor mats that are deep tread with an upright outer ridge that keeps the mud and water on the mat
10. 3 sets of keys

**DEALER COMPLETE IN DETAIL:**

**2015 MAKE \_\_\_\_\_ MODEL \_\_\_\_\_ GVWR \_\_\_\_\_ EACH \$ \_\_\_\_\_**

**GAS MPG: CITY \_\_\_\_\_ HWY \_\_\_\_\_ FUEL CAPACITY \_\_\_\_\_ OIL CAPACITY \_\_\_\_\_**

**IS THIS ENGINE E-85 COMPATIBLE? \_\_\_\_\_ IF SO WHAT IS E-85 MPG: CITY \_\_\_\_\_ HWY \_\_\_\_\_**

**BUMPER TO BUMPER WARRANTY \_\_\_\_\_**

**POWERTRAIN WARRANTY \_\_\_\_\_**

**EXTENDED WARRANTY \_\_\_\_\_**

**OPTIONAL EQUIPMENT PRICES, Item # 17**

**Indicate the additional cost or deduction for the below listed options. Prices should include all required options and special equipment.**

**Option 17A. Power windows and power door locks EACH \$ \_\_\_\_\_**

**Option 17B. Towing Package: Manufacturer's standard to include heavy duty engine oil and transmission cooling systems, Class III frame hitch and 4 pin wiring installed plus wiring harness for 7 pin. EACH \$ \_\_\_\_\_**

**Option 17C. Privacy Glass EACH \$ \_\_\_\_\_**

**Option 17D. Defroster Rear Window, Electric EACH \$ \_\_\_\_\_**

**OPTIONAL EQUIPMENT PRICES, Item # 17 continued**

**Option 17E. Rear Windshield Wiper EACH \$ \_\_\_\_\_**

**Option 17F. Bluetooth Capability EACH \$ \_\_\_\_\_**

**Please indicate below the percent (%) discount off Manufacturer's Suggested Retail Prices (MSRP) for all vehicle options available in your data book or pricing guides.**

***Discount off MSRP for all Data Book or Pricing Guide Options: - % Discount \_\_\_\_\_***

**Delivery will be made approximately \_\_\_\_\_ days after receipt of order.**

**Item #18– New standard equipped 2015 Cargo Mini-Van**

**ACCEPTABLE MAKES AND MODELS:**

Standard Chevrolet City Express  
Standard Ford Transit Connect  
Standard Dodge ProMaster Cargo Van

**All units must contain the following options:**

1. Standard minimum 4 cylinder gas engine (Size \_\_\_\_\_ Horsepower \_\_\_\_\_)
2. Automatic transmission (Speeds \_\_\_\_\_)
3. Factory installed front and rear heat/air conditioning
4. LH & RH mirrors
5. Four manufacturer's all-season tires plus manufacturer's standard size spare tire and wheel (Size) \_\_\_\_\_
6. 4 wheel anti-lock braking system (ABS)
7. Speed control and tilt wheel
8. Rubber floor mats that are deep tread with an upright outer ridge that keeps the mud and water on the mat
9. 3 sets of keys

**DEALER COMPLETE IN DETAIL:**

2015 MAKE \_\_\_\_\_ MODEL \_\_\_\_\_ GVWR \_\_\_\_\_ EACH \$ \_\_\_\_\_  
GAS MPG: CITY \_\_\_\_\_ HWY \_\_\_\_\_ FUEL CAPACITY \_\_\_\_\_ OIL CAPACITY \_\_\_\_\_  
IS THIS ENGINE E-85 COMPATIBLE? \_\_\_\_\_ IF SO WHAT IS E-85 MPG: CITY \_\_\_\_\_ HWY \_\_\_\_\_  
BUMPER TO BUMPER WARRANTY \_\_\_\_\_  
POWERTRAIN WARRANTY \_\_\_\_\_  
EXTENDED WARRANTY \_\_\_\_\_

**OPTIONAL EQUIPMENT PRICES, Item # 18**

Indicate the additional cost or deduction for the below listed options. Prices should include all required options and special equipment.

- Option 18A. Power windows and power door locks EACH \$ \_\_\_\_\_
- Option 18B. Towing Package: Manufacturer's standard to include heavy duty engine oil and transmission cooling systems, Class III frame hitch and 4 pin wiring installed plus wiring harness for 7 pin. EACH \$ \_\_\_\_\_
- Option 18C. Privacy Glass EACH \$ \_\_\_\_\_
- Option 18D. Defroster Rear Window, Electric EACH \$ \_\_\_\_\_
- Option 18E. Rear Windshield Wiper EACH \$ \_\_\_\_\_
- Option 18F. Bluetooth Capability EACH \$ \_\_\_\_\_

Please indicate below the percent (%) discount off Manufacturer's Suggested Retail Prices (MSRP) for all vehicle options available in your data book or pricing guides.

Discount off MSRP for all Data Book or Pricing Guide Options: - % Discount \_\_\_\_\_

Delivery will be made approximately \_\_\_\_\_ days after receipt of order.

**ITEM # 19 - New standard equipped 2014 Small-Size 4-Door Sedan**

**ACCEPTABLE MAKES AND MODELS:**

Standard Dodge Dart  
Standard Ford Focus  
Standard Chevrolet Cruze

**All units must contain the following options:**

1. Standard, minimum 4 cylinder gas engine (Size \_\_\_\_\_ Horsepower \_\_\_\_\_)
2. Automatic Transmission, (Speeds \_\_\_\_\_)
3. Air conditioning
4. LH & RH mirrors
5. Four manufacturer's all-season tires plus manufacturer's standard size spare tire and wheel (Size \_\_\_\_\_)
6. ABS Brakes 4 Wheel
7. Brakes, Hydraulic power, front and rear disc
8. Speed control and tilt wheel
9. Rubber floor mats that are deep tread with an upright outer ridge that keeps the mud and water on the mat
10. 3 sets of keys

**DEALER COMPLETE IN DETAIL:**

2015 MAKE \_\_\_\_\_ MODEL \_\_\_\_\_ EACH \$ \_\_\_\_\_

GAS MPG: CITY \_\_\_\_\_ HWY \_\_\_\_\_ FUEL CAPACITY \_\_\_\_\_ OIL CAPACITY \_\_\_\_\_

IS THIS ENGINE E-85 COMPATIBLE? \_\_\_\_\_ IF SO WHAT IS E-85 MPG: CITY \_\_\_\_\_ HWY \_\_\_\_\_

BUMPER TO BUMPER WARRANTY \_\_\_\_\_

POWERTRAIN WARRANTY \_\_\_\_\_

EXTENDED WARRANTY \_\_\_\_\_

**OPTIONAL EQUIPMENT PRICES, Item # 19**

Indicate the additional cost or deduction for the below listed options, which should include all required options and special equipment.

Option 19A. Power windows and Door Locks EACH \$ \_\_\_\_\_

Option 19B. Defroster Rear Window electric EACH \$ \_\_\_\_\_

Option 19C. Alternate V6 or larger engine in lieu of 4 cylinder (Specify Size) \_\_\_\_\_ (Horsepower) \_\_\_\_\_

E-85 Compatible? \_\_\_\_\_ EACH \$ \_\_\_\_\_

Option 19D. Alternate Diesel engine (Specify Liter Size) \_\_\_\_\_ (Horsepower) \_\_\_\_\_

B-20 Compatible? \_\_\_\_\_ EACH \$ \_\_\_\_\_

Option 19E. Bluetooth Capability EACH \$ \_\_\_\_\_

Please indicate below the percent (%) discount off Manufacturer's Suggested Retail Prices (MSRP) for all vehicle options available in your data book or pricing guides.

Discount off MSRP for all Data Book or Pricing Guide Options: - % Discount \_\_\_\_\_

Delivery will be made approximately \_\_\_\_\_ days after receipt of order.

**ITEM # 20 - New standard equipped 2015 Mid-Size 4-Door Sedan, Alternative Fuel**

**ACCEPTABLE MAKES AND MODELS:**

Standard Chrysler 200  
Standard Dodge Avenger  
Standard Chevrolet Malibu  
Standard Ford Fusion

**All units must contain the following options:**

1. Standard, minimum 1.6L 4 cylinder Turbo or 4 cylinder 2.4 L flex-fuel engine (Specify Size) \_\_\_\_\_ Horsepower \_\_\_\_\_
2. Automatic Transmission, (Speeds \_\_\_\_\_)
3. Air conditioning
4. LH & RH mirrors
5. Four manufacturer's all-season tires plus manufacturer's standard size spare tire and wheel (Size) \_\_\_\_\_
6. ABS Brakes 4 Wheel
7. Brakes, Hydraulic power, front and rear disc
8. Speed control and tilt wheel
9. Rubber floor mats that are deep tread with an upright outer ridge that keeps the mud and water on the mat
10. Three (3) sets of keys

**DEALER COMPLETE IN DETAIL:**

2015 MAKE \_\_\_\_\_ MODEL \_\_\_\_\_ EACH \$ \_\_\_\_\_

GAS MPG: CITY \_\_\_\_\_ HWY \_\_\_\_\_ FUEL CAPACITY \_\_\_\_\_ OIL CAPACITY \_\_\_\_\_

IS THIS ENGINE E-85 COMPATIBLE? \_\_\_\_\_ IF SO WHAT IS E-85 MPG: CITY \_\_\_\_\_ HWY \_\_\_\_\_

BUMPER TO BUMPER WARRANTY \_\_\_\_\_

POWERTRAIN WARRANTY \_\_\_\_\_

EXTENDED WARRANTY \_\_\_\_\_

**OPTIONAL EQUIPMENT PRICES, Item # 20**

Indicate the additional cost or deduction for the below listed options, which should include all required options and special equipment.

Option 20A. Power windows and Door Locks EACH \$ \_\_\_\_\_

Option 20B. Defroster Rear Window electric EACH \$ \_\_\_\_\_

Option 20C. Alternate V6 or larger engine in lieu of 4 cylinder (Specify) (Size) \_\_\_\_\_ (Horsepower) \_\_\_\_\_

E-85 Compatible? \_\_\_\_\_ EACH \$ \_\_\_\_\_

Option 20D. Bluetooth Capability EACH \$ \_\_\_\_\_

Please indicate below the percent (%) discount off Manufacturer's Suggested Retail Prices (MSRP) for all vehicle options available in your data book or pricing guides.

Discount off MSRP for all Data Book or Pricing Guide Options: - % Discount \_\_\_\_\_

Delivery will be made approximately \_\_\_\_\_ days after receipt of order.



**ITEM # 21 - New standard equipped 2015 Mid-Size 4-Door Sedan, Gas Engine**

**ACCEPTABLE MAKES AND MODELS:**

Standard Chrysler 200  
Standard Dodge Avenger  
Standard Chevrolet Malibu  
Standard Ford Fusion

**All units must contain the following options:**

1. Standard, minimum 4 cylinder engine (Size \_\_\_\_\_ Horsepower \_\_\_\_\_)
2. Automatic Transmission
3. Air conditioning
4. LH & RH mirrors
5. Four manufacturer's all-season tires plus manufacturer's standard size spare tire and wheel (Size) \_\_\_\_\_
6. ABS Brakes 4 Wheel
7. Brakes, Hydraulic power, front and rear disc
8. Speed control and tilt wheel
9. Rubber floor mats that are deep tread with an upright outer ridge that keeps the mud and water on the mat
10. 3 sets of keys

**DEALER COMPLETE IN DETAIL:**

2015 MAKE \_\_\_\_\_ MODEL \_\_\_\_\_ EACH \$ \_\_\_\_\_

GAS MPG: CITY \_\_\_\_\_ HWY \_\_\_\_\_ FUEL CAPACITY \_\_\_\_\_ OIL CAPACITY \_\_\_\_\_

BUMPER TO BUMPER WARRANTY \_\_\_\_\_

POWERTRAIN WARRANTY \_\_\_\_\_

EXTENDED WARRANTY \_\_\_\_\_

**OPTIONAL EQUIPMENT PRICES, Item # 21**

Indicate the additional cost or deduction for the below listed options, which should include all required options and special equipment.

Option 21A. Power windows and Door Locks EACH \$ \_\_\_\_\_

Option 21B. Defroster Rear Window electric EACH \$ \_\_\_\_\_

Option 21C. Alternate V6 engine in lieu of 4 cylinder (Size) \_\_\_\_\_ (Horsepower) \_\_\_\_\_ EACH \$ \_\_\_\_\_

Option 21D. Bluetooth Capability EACH \$ \_\_\_\_\_

Please indicate below the percent (%) discount off Manufacturer's Suggested Retail Prices (MSRP) for all vehicle options available in your data book or pricing guides.

Discount off MSRP for all Data Book or Pricing Guide Options: - % Discount \_\_\_\_\_

Delivery will be made approximately \_\_\_\_\_ days after receipt of order.

**ITEM # 22 - New standard equipped 2015 Mid-Size 4-Door Sedan, Hybrid Engine**

**ACCEPTABLE MAKES AND MODELS:**

Standard Ford Fusion

**All units must contain the following options:**

1. Hybrid engine (Size \_\_\_\_\_ Horsepower \_\_\_\_\_)
2. Automatic Transmission
3. Air conditioning
4. LH & RH mirrors
5. Four manufacturer's all-season tires plus manufacturer's standard size spare tire and wheel (Size) \_\_\_\_\_
6. ABS Brakes 4 Wheel
7. Brakes, Hydraulic power, front and rear disc
8. Speed control and tilt wheel
9. Rubber floor mats that are deep tread with an upright outer ridge that keeps the mud and water on the mat
10. 3 sets of keys

**DEALER COMPLETE IN DETAIL:**

2015 MAKE \_\_\_\_\_ MODEL \_\_\_\_\_ EACH \$ \_\_\_\_\_

MPG: CITY \_\_\_\_\_ HWY \_\_\_\_\_ FUEL CAPACITY \_\_\_\_\_ OIL CAPACITY \_\_\_\_\_

BUMPER TO BUMPER WARRANTY \_\_\_\_\_

POWERTRAIN WARRANTY \_\_\_\_\_

EXTENDED WARRANTY \_\_\_\_\_

**OPTIONAL EQUIPMENT PRICES, Item # 22**

Indicate the additional cost or deduction for the below listed options, which should include all required options and special equipment.

Option 22A. Power windows and Door Locks EACH \$ \_\_\_\_\_

Option 22B. Defroster Rear Window electric EACH \$ \_\_\_\_\_

Option 22C. Bluetooth Capability EACH \$ \_\_\_\_\_

Please indicate below the percent (%) discount off Manufacturer's Suggested Retail Prices (MSRP) for all vehicle options available in your data book or pricing guides.

Discount off MSRP for all Data Book or Pricing Guide Options: - % Discount \_\_\_\_\_

Delivery will be made approximately \_\_\_\_\_ days after receipt of order.

**ITEM # 23 - New standard equipped 2015 Full Size 4-Door Sedan, Alternative Fuel**

**ACCEPTABLE MAKES AND MODELS:**

Standard Chevrolet Impala

**All units must contain the following options:**

1. 3.0 L 6, cylinder minimum flex fuel E-85 and gas engine. (Size \_\_\_\_\_ Horsepower \_\_\_\_\_)
2. Automatic, Transmission (Speeds \_\_\_\_\_)
3. Air conditioning
4. Four manufacturer's all-season tires plus manufacturer's standard size spare tire and wheel (Size) \_\_\_\_\_
5. Brakes, Power 4-Wheel ABS
6. Speed control and tilt wheel
7. Body Side Molding
8. Power windows and door locks
9. Rubber floor mats that are deep tread with an upright outer ridge that keeps the mud and water on the mat
10. 3 sets of keys

**DEALER COMPLETE IN DETAIL:**

2015 MAKE \_\_\_\_\_ MODEL \_\_\_\_\_ EACH \$ \_\_\_\_\_

GAS MPG: CITY \_\_\_\_\_ HWY \_\_\_\_\_ FUEL CAPACITY \_\_\_\_\_ OIL CAPACITY \_\_\_\_\_

IS THIS ENGINE E-85 COMPATIBLE? \_\_\_\_\_

IF SO WHAT IS E-85 MPG: CITY \_\_\_\_\_ HWY \_\_\_\_\_

BUMPER TO BUMPER WARRANTY \_\_\_\_\_

POWERTRAIN WARRANTY \_\_\_\_\_

EXTENDED WARRANTY \_\_\_\_\_

**OPTIONAL EQUIPMENT PRICES, Item # 23**

Indicate the additional cost or deduction for the below listed options, which should include all required options and special equipment.

Option 23A. Defroster, Rear Window Electric EACH \$ \_\_\_\_\_

Option 23B. Head Curtain Side air Bags Front and Rear EACH \$ \_\_\_\_\_

Option 23C. Bluetooth Capability EACH \$ \_\_\_\_\_

Please indicate below the percent (%) discount off Manufacturer's Suggested Retail Prices (MSRP) for all vehicle options available in your data book or pricing guides.

Discount off MSRP for all Data Book or Pricing Guide Options: - % Discount \_\_\_\_\_

Delivery will be made approximately \_\_\_\_\_ days after receipt of order.

**ITEM # 24 - New standard equipped 2015 Full Size 4-Door Sedan, Gas Engine**

**ACCEPTABLE MAKES AND MODELS:**

Standard Chevrolet Impala  
Standard Ford Taurus

**All units must contain the following options:**

1. 6 cylinder gas engine. (Size \_\_\_\_\_ Horsepower \_\_\_\_\_)
2. Automatic, Transmission (Speeds \_\_\_\_\_)
3. Air conditioning
4. Four manufacturer's all-season tires plus manufacturer's standard size spare tire and wheel (Size) \_\_\_\_\_
5. Brakes, Power 4-Wheel ABS
6. Speed control and tilt wheel
7. Body Side Molding
8. Power windows and door locks
9. Rubber floor mats that are deep tread with an upright outer ridge that keeps the mud and water on the mat
10. 3 sets of keys

**DEALER COMPLETE IN DETAIL:**

2015 MAKE \_\_\_\_\_ MODEL \_\_\_\_\_ EACH \$ \_\_\_\_\_

GAS MPG: CITY \_\_\_\_\_ HWY \_\_\_\_\_ FUEL CAPACITY \_\_\_\_\_ OIL CAPACITY \_\_\_\_\_

BUMPER TO BUMPER WARRANTY \_\_\_\_\_

POWERTRAIN WARRANTY \_\_\_\_\_

EXTENDED WARRANTY \_\_\_\_\_

**OPTIONAL EQUIPMENT PRICES, Item # 24**

Indicate the additional cost or deduction for the below listed options, which should include all required options and special equipment.

Option 24A. Defroster, Rear Window Electric EACH \$ \_\_\_\_\_

Option 24B. Head Curtain Side air Bags Front and Rear EACH \$ \_\_\_\_\_

Option 24C. Bluetooth Capability EACH \$ \_\_\_\_\_

Option 24D. Optional 4 cylinder engine in lieu of standard 6 cylinder engine

State Liter Size \_\_\_\_\_ Horsepower \_\_\_\_\_ EACH \$ \_\_\_\_\_

Please indicate below the percent (%) discount off Manufacturer's Suggested Retail Prices (MSRP) for all vehicle options available in your data book or pricing guides.

Discount off MSRP for all Data Book or Pricing Guide Options: - % Discount \_\_\_\_\_

Delivery will be made approximately \_\_\_\_\_ days after receipt of order.

# VENDOR INFORMATION & PREFERENCE CERTIFICATION FORM

## Vendor Information

**All bidders must furnish ALL applicable information requested below**

<b>Vendor Name/Mailing Address:</b>  Email Address:	<b>Vendor Contact Information (including area codes):</b> Phone #: Cellular #: Fax #:									
<b>Printed Name of Responsible Officer or Employee:</b>	<b>Signature:</b>									
<b>For Corporations - State in which incorporated:</b>	<b>For Others - State of domicile:</b>									
If the address listed in the Vendor Name/Mailing Address block above is not located in the State of Missouri, list the address of Missouri offices or places of business:  If additional space is required, please attach an additional sheet and identify it as <b><u>Addresses of Missouri Offices or Places of Business.</u></b>										
<b>M/WBE INFORMATION:</b> List all certified Minority or Women Business Enterprises ( <b><u>M/WBE</u></b> ) utilized in the fulfillment of this bid. Include <u>percentages</u> for subcontractors and identify the M/WBE certifying agency:  <table style="width: 100%; border-collapse: collapse;"> <thead> <tr> <th style="text-align: center; width: 33%;"><u>M/WBE Name</u></th> <th style="text-align: center; width: 33%;"><u>Percentage of Contract</u></th> <th style="text-align: center; width: 33%;"><u>M/WBE Certifying Agency</u></th> </tr> </thead> <tbody> <tr> <td>_____</td> <td>_____</td> <td>_____</td> </tr> <tr> <td>_____</td> <td>_____</td> <td>_____</td> </tr> </tbody> </table> If additional space is required, please attach an additional sheet and identify it as <b><u>M/WBE Information</u></b>		<u>M/WBE Name</u>	<u>Percentage of Contract</u>	<u>M/WBE Certifying Agency</u>	_____	_____	_____	_____	_____	_____
<u>M/WBE Name</u>	<u>Percentage of Contract</u>	<u>M/WBE Certifying Agency</u>								
_____	_____	_____								
_____	_____	_____								

## Preference Certification

**All bidders must furnish ALL applicable information requested below**

<b><u>GOODS/PRODUCTS MANUFACTURED OR PRODUCED IN USA:</u></b> If any or all of the goods or products offered in the attached bid which the bidder proposes to supply to the MHTC are <b>not</b> manufactured or produced in the "United States", or imported in accordance with a qualifying treaty, law, agreement, or regulation, list below, by item or item number, the country other than the United States where each good or product is manufactured or produced.	
Item (or item number)	Location Where Item is Manufactured or Produced
If additional space is required, please attach an additional sheet and identify it as <b><u>Location Products are Manufactured or Produced.</u></b>	
<b><u>MISSOURI SERVICE-DISABLED VETERAN BUSINESS:</u></b> Please complete the following if applicable. Additional information may be requested if preference is applicable. See below definitions for qualification criteria: <b>Service-Disabled Veteran</b> is defined as any individual who is disabled as certified by the appropriate federal agency responsible for the administration of veterans' affairs. <b>Service-Disabled Veteran Business</b> is defined as a business concern: <ol style="list-style-type: none"> <li>a. Not less than fifty-one (51) percent of which is owned by one or more service-disabled veterans or, in the case of any publicly owned business, not less than fifty-one (51) percent of the stock of which is owned by one or more service-disabled veterans; and</li> <li>b. The management and daily business operations of which are controlled by one or more service-disabled veterans.</li> </ol>	
<u>Veteran Information</u>	<u>Business Information</u>
_____ Service-Disabled Veteran's Name (Please Print)	_____ Service-Disabled Veteran Business Name
_____ Service-Disabled Veteran's Signature	_____ Missouri Address of Service Disabled Veteran Business

**NOTICE OF COOPERATIVE PURCHASING**

**MODOT IS INTERESTED IN ASSISTING MISSOURI GOVERNMENTAL ENTITIES, ETC. IN PURCHASING EQUIPMENT, VARIOUS MATERIALS, AND SUPPLIES THAT MEET THE MISSOURI DEPARTMENT OF TRANSPORTATION SPECIFICATIONS.**

Each bidder is asked to indicate below whether they would be willing to offer light duty vehicles listed in the attached "Request for Bid" for sale to these local political entities at the same bid price offered to MoDOT.

It is understood MoDOT will not issue purchase orders, accept delivery nor make payment for these items ordered by any of these agencies. It is further understood the price is based on the light duty vehicle meeting MoDOT specifications. Any added options, deletions, or extra freight costs would be negotiated between the local agency and the successful vendor.

Indicate below whether your company is willing to offer such cooperative purchasing for Missouri counties, cities or other political entities.

YES \_\_\_\_\_ NO \_\_\_\_\_

If the price varies throughout the state on MoDOT bids because of different delivery destinations, please indicate the price F.O.B. your location that would be offered as described.

F.O.B. Location \_\_\_\_\_

Indicate the deadline date that orders will be accepted. \_\_\_\_\_

COMPANY NAME \_\_\_\_\_

ADDRESS \_\_\_\_\_

E-MAIL \_\_\_\_\_

PHONE NUMBER \_\_\_\_\_

SIGNATURE \_\_\_\_\_

TITLE \_\_\_\_\_

DATE \_\_\_\_\_



**Missouri Highways and Transportation Commission  
Standard Bid Provisions, General Terms and Conditions and Special Terms and Conditions**

**STANDARD SOLICITATION PROVISIONS**

- a. The solicitation for the procurement of the supplies referenced therein, to which these "Standard Bid Provisions, General Terms and Conditions and Special Terms and Conditions" are attached, is being issued under, and governed by, the provisions of Title 7 – Missouri Department of Transportation, Division 10 – Missouri Highways and Transportation Commission, Chapter 11 – Procurement of Supplies, of the Code of State Regulations. The Missouri Highways and Transportation Commission (MHTC), acting by and through its operating arm, the Missouri Department of Transportation (MoDOT), draws the Bidder's attention to said 7 CSR 10-11 for all the provisions governing solicitation and receipt of bids/quotes and the award of the contract pursuant to this solicitation.
- b. All bids/quotes must be signed with the firm name and by a responsible officer or employee. Obligations assumed by such signature must be fulfilled.

**GENERAL TERMS AND CONDITIONS**

**Definitions**

Capitalized terms as well as other terms used but not defined herein shall have the meaning assigned to them in section 7 CSR 10-11.010 Definition of Terms.

**Nondiscrimination**

- a. The Contractor shall comply with all state and federal statutes applicable to the Contractor relating to nondiscrimination, including, but not limited to, Chapter 213, RSMo; Title VI and Title VII of Civil Rights Act of 1964 as amended (42 U.S.C. Sections 2000d and 2000e, *et seq.*); and with any provision of the "Americans with Disabilities Act" (42 U.S.C. Section 12101, *et seq.*)
- b. **Sanctions for Noncompliance:** In the event of the Contractor's noncompliance with the nondiscrimination provisions of this contract, MHTC shall impose such contract sanctions as it or the Federal Highway Administration may determine to be appropriate, including, but not limited to:
  - i. withholding of payments to the Contractor under the contract until the Contractor complies, and/or,
  - ii. cancellation, termination or suspension of the contract, in whole or in part.

**Contract/Purchase Order**

- a. By submitting a bid/quote, the Bidder agrees to furnish any and all equipment, supplies and/or services specified in the solicitation documents, at the prices quoted, pursuant to all requirements and specifications contained therein.
- b. A binding contract shall consist of: (1) the solicitation documents, amendments thereto, and/or Best and Final Offer (BAFO) request(s) with any changes/additions, (2) the Contractor's bid response, and (3) the MHTC's acceptance of the bid by post-award contract or purchase order.
- c. A notice of award does not constitute an authorization for shipment of equipment or supplies or a directive to proceed with services. Before providing equipment, supplies and/or services, the Contractor must receive a properly authorized notice to proceed and/or purchase order.

**Applicable Laws and Regulations**

- a. The contract shall be construed according to the laws of the State of Missouri. The Contractor shall comply with all local, state, and federal laws and regulations related to the performance of the contract. The exclusive venue for any legal proceeding relating to or arising, out of the contract shall be in the Circuit Court of Cole County, Missouri.
- b. The Contractor must be registered and maintain good standing with the Secretary of State of the State of Missouri, Missouri Department of Revenue, and other regulatory agencies, as may be required by law or regulations. Prior to the issuance of a purchase order and/or notice to proceed, the Contractor may be required to submit to MHTC a copy of their current Authority Certificate from the Secretary of State of the State of Missouri and/or a copy of their Certificate of No Tax Due from the Missouri Department of Revenue.
- c. Prior to the issuance of a purchase order and/or notice to proceed, all **out-of-state** Contractors **providing services** within the state of Missouri must submit to MHTC a copy of their current Transient Employer Certificate from the Missouri Department of Revenue, in addition to a copy of their current Authority Certificate from the Secretary of State of the State of Missouri.

**Executive Order:**

The Contractor shall comply with all the provisions of Executive Order 07-13, issued by the Honorable Matt Blunt, Governor of Missouri, on the sixth (6<sup>th</sup>) day of March, 2007. This Executive Order, which promulgates the State of Missouri's position to not tolerate persons who contract with the state engaging in or supporting illegal activities of employing individuals who are not eligible to work in the United States, is incorporated herein by reference and made a part of this Agreement.

- 1) "By signing this Agreement, the Contractor hereby certifies that any employee of the Contractor assigned to perform services under the contract is eligible and authorized to work in the United States in compliance with federal law."
- 2) In the event the Contractor fails to comply with the provisions of the Executive Order 07-13, or in the event the Commission has reasonable cause to believe that the contractor has knowingly employed individuals who are not eligible to work in the United States in violation of federal law, the Commission reserves the right to impose such contract sanctions as it may determine to be appropriate, including but not limited to contract cancellation, termination or suspension in whole or in part or both.
- 3) The Contractor shall include the provisions of this paragraph in every subcontract. The Contractor shall take such action with respect to any subcontract as the Commission may direct as a means of enforcing such provisions, including sanctions for noncompliance.

**Preferences**

- a. In the evaluation of bids/quotes, preferences shall be applied in accordance with 7 CSR 10-11.020(7). Contractors should apply the same preferences in selecting subcontractors. The attached document entitled "**VENDOR INFORMATION AND PREFERENCE CERTIFICATION FORM**" must be completed and returned with the solicitation documents.
- b. Bidders are encouraged to obtain minority business enterprise (MBE) and women business enterprise (WBE) participation in this work through the use of subcontractors, suppliers, joint ventures, or other arrangements that afford meaningful participation for M/WBEs. Bidders are encouraged to obtain 10% MBE and 5% WBE participation.



**Missouri Highways and Transportation Commission**  
**Standard Bid Provisions, General Terms and Conditions and Special Terms and Conditions**

**Cancellation of Contract**

The MHTC may cancel the Contract at any time for a material breach of contractual obligations or for convenience by providing Contractor with written notice of cancellation. Should the MHTC exercise its right to cancel the contract for such reasons, cancellation will become effective upon the date specified in the notice of cancellation sent to the Contractor.

**Bankruptcy or Insolvency**

Upon filing for any bankruptcy or insolvency proceeding by or against the Contractor, whether voluntarily, or upon the appointment of a receiver, trustee, or assignee, for the benefit of creditors, the Commission reserves the right and sole discretion to either cancel the Agreement or affirm the Agreement and hold the Contractor responsible for damages.

**Warranty**

The Contractor expressly warrants that all equipment, supplies, and/or services provided shall: (1) conform to each and every specification, drawing, sample or other description which was furnished to or adopted by the MHTC, (2) be fit and sufficient for the purpose expressed in the solicitation documents, (3) be merchantable, (4) be of good materials and workmanship, and (5) be free from defect.

**Status of Independent Contractor**

The Contractor represents itself to be an independent Contractor offering such services to the general public and shall not represent itself or its employees to be an employee of the MHTC. Therefore, the Contractor shall assume all legal and financial responsibility for taxes, FICA, employee fringe benefits, workers' compensation, employee insurance, minimum wage requirements, overtime, etc., and agrees to indemnify, save and hold the MHTC, its officers, agents and employees harmless from and against any and all losses (including attorney fees) and damage of any kind related to such matters.

**Non-Waiver**

If one of the parties agrees to waive its right to enforce any term of this Contract, that party does not waive its right to enforce such term at any other time or to enforce any or all other terms of this Contract.

**Indemnification**

The Contractor shall defend, indemnify and hold harmless MHTC, including its members and department employees, from any claim or liability whether based on a claim for damages to real or personal property or to a person for any matter relating to or arising out of the Contractor's performance of its obligations under the contract awarded pursuant to this solicitation.

**Missouri Highways and Transportation Commission**  
**Standard Bid/Proposal Provisions, General Terms and Conditions and Special Terms and Conditions**

**SPECIAL TERMS AND CONDITIONS**

**Tax Exempt Status:**

MHTC is exempt from paying Missouri Sales Tax, Missouri Use Tax and Federal Excise Tax. However, the Contractor may themselves be responsible for the payment of taxes on materials they purchase to fulfill the contract. A Project Tax Exemption Certificate will be furnished to the successful Bidder upon request if applicable.

**Liquidated Damages**

- a. In the event the successful Contractor fails to deliver the material within the time specified, the Department and the public will sustain damages because of such delay in delivery, the exact extent of which would be difficult to ascertain, and in order to liquidate such damage in advance it is agreed that the **sum of \$100 per day, per item**, for each assessable calendar day on which the delivery has not been completed, is reasonable and the best estimate which the parties can arrive at as liquidated damages, and it is therefore agreed that said amount will be withheld from payments due the Contractor or otherwise collected from the Contractor as liquidated damages.
- b. **Saturdays, Sundays, holidays and days whereas the Department has suspended work** shall not be assessable days.

# CERTIFIED COPY OF ORDER

STATE OF MISSOURI

} ea.

January Session of the January Adjourned

Term. 20 16

County of Boone

In the County Commission of said county, on the

7th

day of

January

20

16

the following, among other proceedings, were had, viz:

Now on this day the County Commission of the County of Boone does hereby award bid 77-10DEC15 – Radio Tower Erection Work for the Battle School Project to Spectrum Antenna Services, Inc. of Lone Jack, MO.

The terms of the bid award are stipulated in the attached Contract Agreement. It is further ordered the Presiding Commissioner is hereby authorized to sign said Contract Agreement.

Done this 7th day of January, 2016.

ATTEST:

Wendy S. Noren  
Wendy S. Noren  
Clerk of the County Commission

[Signature]

Daniel K. Atwill  
Presiding Commissioner

[Signature]

Karen M. Miller  
District I Commissioner

Absent

Janet M. Thompson  
District II Commissioner

12-2016

# Boone County Purchasing

**Melinda Bobbitt, CPPO, CPPB**  
Director of Purchasing



613 E. Ash St., Room 110  
Columbia, MO 65201  
Phone: (573) 886-4391  
Fax: (573) 886-4390

---

## MEMORANDUM

**TO:** Boone County Commission  
**FROM:** Melinda Bobbitt, CPPO, CPPB  
**DATE:** December 31, 2015  
**RE:** Bid Award Recommendation: *77-10DEC15 – Radio Tower Erection Work for the Battle School Project*

Request for Bid *77-10DEC15 – Radio Tower Erection for the Battle School Project* closed on December 10, 2015. Two bids were received. Dave Dunford, our Radio Consultant, recommends award to Spectrum Antenna Services, Inc. of Lone Jack, Missouri for offering the lowest and best bid.

Contract award is \$11,925.00 and will be paid from department 2704 – Joint Comm Radio Network, Account 91300 – Machinery & Equipment. \$35,000 was estimated by our radio consultant.

ATT: Bid Tab

cc: Bid File  
Karen Miller, Commission  
Dave Dunford, Radio Consultant  
Chad Martin, Patricia Schreiner, Joint Communications

BID TABULATION: 77-10DEC15 - RADIO TOWER ERECTION FOR BATTLE SCHOOL PROJECT				
Item #	Description	Radio Consultant Estimate	Mercury Communications	Spectrum Antenna Services, Inc.
4.01.	Radio Tower Erection per the Requirements Stated in the RFB.	\$35,000	\$17,365.00	\$11,925.00
4.02.	How many days after Notice to Proceed will work begin?		5	15
4.03.	How many days after Notice to Proceed will work be completed?		5	15
4.04.	List Subcontractors Name, Address, and Work Assigned.		None	Scott's Crane Rental, Monopole Off Load & Erection

12-2016

## **CONTRACT AGREEMENT**

THIS AGREEMENT, made and entered into by and between the County of Boone through the Boone County Commission (hereinafter referred to as the Owner), and **Spectrum Antenna Services, Inc.** (hereinafter referred to as the Contractor).

WITNESSETH: That for and in consideration of the acceptance of Contractor's bid and the award of this contract to said Contractor by the Owner and in further consideration of the agreements of the parties herein contained, to be well and truly observed and faithfully kept by them, and each of them, it is agreed between the parties as follows, to wit:

The Contractor at his own Expense hereby agrees to do or furnish all labor, materials, and equipment called for in the bid designated and marked:

**BID NUMBER 77-10DEC15  
RADIO TOWER ERECTION  
FOR THE BATTLE SCHOOL PROJECT  
BOONE COUNTY, MISSOURI**

and agrees to perform all the work required by the contract as shown in the bid document. The contract award shall be for providing all required materials, supplies, equipment, tools and plant; to provide and perform all necessary labor and supervision; and to install, erect, equip, and complete Radio Tower and Erection for the Battle School Project.

Contractor agrees to begin the work within 15 days after receipt of Notice to Proceed and complete the above work within 15 days after receipt of Purchase Order and Notice to Proceed from the Purchasing Department.

The following contract documents and any applicable Addenda are made a part hereof as fully as if set out herein: Change orders issued subsequent to this contract shall be subject to the terms and conditions of the agreement unless otherwise specified in writing.

- Introduction and General Conditions of Bidding
- Primary Specifications
- Response Presentation and Review
- Response Form
- Statement of Bidder's Qualifications
- Standard Terms and Conditions
- Work Authorization Certification
- Debarment Certification
- Anti-Collusion Statement
- Signature and Identify of Bidder
- Bidder's Acknowledgment
- Annual Wage Order #22, dated 10/20/15
- Insurance Requirements
- Affidavit of Compliance with OSHA
- Affidavit of Compliance with Prevailing Wage Law
- Spectrum Antenna Services, Inc. Bid Response dated 12/07/15

12-2016

The Contractor agrees that he is fully informed regarding all of the conditions affecting the work to be done, and labor and materials to be furnished for the completion of this contract, and that his information was secured by personal investigation and research and not from any estimates of the Owner; and that he will make no claim against the Owner by reason of estimates, tests, or representation of any officer, agent, or employees of the Owner.

The said Contractor agrees further to begin work not later than the authorized date in the Notice to Proceed, and to complete the work within the time specified in the contract documents or such additional time as may be allowed by the Project Manager under the contract.

The work shall be done to complete satisfaction of the Owner and, in the case the Federal Government or any agency thereof is participating in the payment of the cost of construction of the work, the work shall also be subject to inspection and approval at all times by the proper agent or officials of such government agency.

The parties hereto agree that this contract in all things shall be governed by the laws of the State of Missouri.

Contractor agrees it will pay not less than the prevailing hourly rate of wages to all workers performing work under the contract in accordance with the prevailing wage determination issued by the Division of Labor Standards of the Department of Labor and Industrial Relations for the State of Missouri and as maintained on file with Boone County Facilities Maintenance Department.

The Contractor further agrees that it shall forfeit as a penalty to the County of Boone the sum of \$100.00 for each worker employed for each calendar day or portion thereof such worker is paid less than the stipulated rates set forth in the prevailing wage determination for the project for any work done under this contract by the Contractor or by any Subcontractor employed by the Contractor pursuant to the provisions of Section 290.250 RSMo. The Contractor further agrees that it will abide by all provisions of the prevailing wage law as set forth in Chapter 290 RSMo. and rules and regulations issued thereunder and that any penalties assessed may be withheld from sums due to the Contractor by the Owner.

The contractor agrees that he will comply with all federal, state, and local laws and regulations and ordinances and that he/she will comply and cause each of his/her subcontractors, and directives pertaining to nondiscrimination against any person on the grounds of race, color, religion, creed, sex, age, ancestry, or national origin in connection with this contract, including procurement of materials and lease of equipment; therefore, in accordance with the special provisions on that subject attached hereto, incorporated in and made a part of the Contract.

The Contractor expressly warrants that he/she has employed no third person to solicit or obtain this contract in his behalf, or to cause or procure the same to be obtained upon compensation in any way contingent, in whole or in part, upon such procurement; and that he has not paid, or promised or agreed to pay to any third person, in consideration of such procurement, or in compensation for services in connection therewith, any brokerage, commission or percentage upon the amount receivable by him hereunder; and that he has not, in estimating the contract price demand by him, included any sum by reason of such brokerage, commission, or percentage; and that all moneys payable to him hereunder are free from obligation of any other person for services rendered, or supposed to have been rendered, in the procurement of this contract. He further agrees that any breach of this warranty shall constitute adequate cause for the annulment of this contract by the Owner, and that the Owner may retain to its own use from any sums due to or to become due hereunder an amount equal to any brokerage, commission, or percentage so paid, or agreed to be paid.

The Contractor is aware of the provisions of the Overhead Power Line Safety Act, 319.075 to 319.090 RSMo, and agrees to comply with the provisions thereof. Contractor understands that is their duty to

12-2016

notify any utility operating high voltage overhead lines and make appropriate arrangements with said utility if the performance of contract would cause any activity within ten feet of any high voltage overhead line. To the fullest extent permitted by law, Contractor shall indemnify, hold harmless and defend the County, its directors, officers, agents, and employees from and against all claims, damages, losses and expenses (including but not limited to attorney's fees) arising by reason of any act or failure to act, negligent or otherwise, of Contractor, of any subcontractor (meaning anyone, including but not limited to consultants having a contract with contractor or a subcontract for part of the services), of anyone directly or indirectly employed by contractor or by any subcontractor, or of anyone for whose acts the contractor or its subcontractor may be liable, in connection with any claims arising under the Overhead Power Line Safety Act. Contractor expressly waives any action for Contribution against the County on behalf of the Contractor, any subcontractor (meaning anyone, including but not limited to consultants having a contract with contractor or a subcontract for part of the services), anyone directly or indirectly employed by contractor or by any subcontractor, or of anyone for whose acts the contractor or its subcontractor may be liable, and agrees to provide a copy of this waiver to any party affected by this provision.



12-2016

The Owner agrees to pay the Contractor in the amount:

**Eleven Thousand Nine Hundred Twenty Five Dollars and Zero Cents (\$11,925.00)**

as full compensation for the performance of work embraced in this contract, subject to the terms of payment as provided in the contract documents and subject to adjustment as provided for changes in quantities, any delays in project completion and approved change orders.

IN WITNESS WHEREOF, the parties hereto have signed and entered this agreement on 1-7-16  
at Columbia, Missouri. (Date)

CONTRACTOR:  
SPECTRUM ANTENNA SERVICES, INC.

OWNER:  
BOONE COUNTY, MISSOURI

By: Jeff Edwards  
Authorized Representative *Signature*

By: Daniel K. Atwill  
Daniel K. Atwill, Presiding Commissioner

By: Jeff Edwards  
Authorized Representative *Printed Name*  
Title: Vice President

Approved as to Legal Form:

ATTEST:

by: [Signature]  
Boone County Counselor

Wendy S. Noren  
Wendy Noren  
Boone County Clerk

**AUDITOR CERTIFICATION**

In accordance with RSMo 50.660, I hereby certify that a sufficient unencumbered appropriation balance exists and is available to satisfy the obligation(s) arising from this contract. (Note: Certification of this contract is not required if the terms of the contract do not create a measurable county obligation at this time.)

2704-91300- \$11,925.00

Jane P. Pitchford by jz  
Signature Date Appropriation Account



**AFFIDAVIT COMPLIANCE WITH THE PREVAILING WAGE LAW**

Before me, the undersigned Notary Public, in and for the County of \_\_\_\_\_

State of \_\_\_\_\_, personally came and appeared (name and title)

\_\_\_\_\_ of the (name of company)

\_\_\_\_\_ (a corporation) (a partnership) (a proprietorship)

and after being duly sworn did depose and say that all provisions and requirements set out in Chapter 290 Sections 290.210 through and including 290.340, Missouri Revised Statutes, pertaining to the payment of wages to workmen employed on public works projects have been fully satisfied and there has been no exception to the full and complete compliance with said provisions and requirements and with Wage Determination NO. \_\_\_\_\_ issued by the Division of Labor Standards on the \_\_\_\_\_ day of \_\_\_\_\_ 20\_\_\_\_, in carrying out the Contract and work in connection with

(name of project) \_\_\_\_\_ located at

(name of institution) \_\_\_\_\_ in \_\_\_\_\_ County,

Missouri and completed on the \_\_\_\_\_ day of \_\_\_\_\_, 20\_\_\_\_\_.

\_\_\_\_\_  
Signature

Subscribed and sworn to me this \_\_\_\_\_ day of \_\_\_\_\_, 20\_\_\_\_\_.

My commission expires \_\_\_\_\_, 20\_\_\_\_\_.

\_\_\_\_\_  
Notary Public

4. Response Form

Company Name: SPECTRUM ANTENNA SERVICES INC  
 Address: P.O. BOX 201  
 City/Zip: LONE JACK MD 64070  
 Phone Number: 816-697-3600  
 E-Mail: MICHOE@LONAS.NET  
 Fax Number: 65-1266207

Federal Tax I.D. 65-1266207  
 Corporation  
 Partnership - Name \_\_\_\_\_  
 Individual/Proprietorship - Individual Name \_\_\_\_\_  
 Other (Specify) \_\_\_\_\_

4.00 **PRICING**

4.01. Radio Tower Erection Service for Battle School project per the requirements stated herein.

ELEVEN NINE HUNDRED TWENTY-FIVE DOLLARS and 00 CENTS  
 (Quoted cost in print) \$ 11,925.00 /LUMP SUM

4.02. Work will begin on project 15 days after receipt of Notice to Proceed.

4.03. Work will be completed 15 days after receipt of Notice to Proceed.

4.04. **Subcontracting:** If Vendor proposes to use subcontractors for this work, list the names of the firms and the work to be assigned in spaces below.

<u>Subcontractor Name/Address</u>	<u>Work Assigned</u>
<u>Scott's Crane Rental</u> <u>109 E. CENTRAL ST</u> <u>HOLTS SUMMIT, MO 65043</u>	<u>manipulate off load + erection</u>

4.05. The undersigned offers to furnish and deliver the articles or services as specified at the prices and terms stated and in strict accordance with all requirements contained in the Request for Bid which have been read and understood, and all of which are made part of this order. By submission of this bid, the vendor certifies that they are in compliance with Section 34.353 and, if applicable, Section 34.359 (Missouri Domestic Products Procurement Act) of the Revised Statutes of Missouri.

Authorized Representative (Sign By Hand):  Date: 12.7.2015

Print Name and Title of Authorized Representative:  
TERESA C. EDWARDS

## STATEMENT OF BIDDER'S QUALIFICATIONS

Each bidder for the work included in the specifications and plans and the Contract Documents shall submit with their bid the data requested in the following schedule of information. This data must be included in and made a part of each bid document and be contained in the sealed envelope. Failure to comply with this instruction may be regarded as justification for rejecting the Contractor's proposal.

1. Name of Bidder: SPECTRUM ANTENNA SERVICES, INC.
2. Business Address: P.O. BOX 201 LONE JACK MO 64670
3. When Organized: JAN. 19, 2006
4. When Incorporated: 1. 19. 2006. List federal tax identification number: 65-1266207  
If not incorporated, state type of business (sole proprietor, partnership, or other) \_\_\_\_\_
6. Number of years engaged in business under present firm name: 10
7. If you have done business under a different name, please give name and business location under that name: \_\_\_\_\_
8. Percent of work done by own staff: 95%
9. Have you ever failed to complete any work awarded to your company? If so, where and why? NO
10. Have you ever defaulted on a contract? NO If so, give \_\_\_\_\_
11. List of contracts completed within the last three years for work similar in scope to that described in this bid, including value of each. SEE ATTACHED
12. List of projects currently in progress: SEE ATTACHED

\* Attach additional sheets as necessary \*

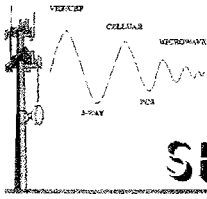

# SPECTRUM ANTENNA SERVICES, INC.

---

December 7, 2015

IN RE: 4.01

Scope:

- 1) MONOPOLE & PLATFORM OFFLOAD
- 2) PLATFORM ASSEMBLY ON GROUND
- 3) MONOPOLE WILL BE STACKED IN PIECES WITH CRANE
- 4) SET PLATFORM WITH CRANE

References:

McGilton Construction  
c/o Tom McGilton  
Parkville, MO  
816-522-9752

City of Lenexa  
c/o Dave Dunford  
816-208-9561



12-07-15

Boone County 911 Center

Scope of Work

1. Operator will drive crane to your site.
2. Operator will set crane up next to your prepared site.
3. Operators then will set mats and counterweights on machine.
4. Operators will level machine and scope out boom.
5. Once tower sections are ready, operator will begin to hoist sections in place.
6. After all sections are installed crane boom will be scoped in.
7. Operators will then remove counterweights and mats.
8. Operator will then drive crane off location.

Tower Erection References:

A&W COMMUNICATIONS

P.O. BOX 66  
EOLIA, MO 63344  
573-485-3500

SPENCER CONTRACTING

3073 ARNOLD TENBROOK RD  
ARNOLD, MO 63010  
314-843-5166

ROGERS TOWER

PO BOX 546  
WARREN, OK 74469  
918-284-3233

FAITH TECHNOLOGIES

1820 N. BARNES  
SPRINGFIELD, MO 65803

MURPHY TOWER SERVICE

20220 HWY 5  
CARLISLE IA 50047  
641-891-3591

**QUESTION 11, PAGE 16**

List of contract completed with in the last three years for work similar in scope to that described in this bid, including value of each:

City of Lenexa – 150’ monopole erection w/ platform - \$4,800

McGilton Construction/City of Lenexa PD – 160’ monopole erection w/ platform - \$10,000

McGilton Construction – 195’ monopole erection w/ platform and A&L - \$13,320

**QUESTION 12, PAGE 16**

List of project currently in progress/under contract: All are A&L upgrades not tower erection and completion dates vary based upon receipt of notice to proceed.

VERIZON WIRELESS:

N. Cameron

Fallbrook

1-435/Quivira

Embassy Suites

CROWN CASTLE

Claycomo

T-MOBILE

A5D0017 BREUER



## INSTRUCTIONS FOR COMPLIANCE WITH HOUSE BILL 1549

House Bill 1549 addresses the Department of Homeland Security's and the Social Security Administration's E-Verify Program (Employment Eligibility Verification Program) that requires the County to verify "lawful presence" of individuals when we contract for work/service; verify that contractor has programs to verify lawful presence of their employees when contracts exceed \$5,000; and a requirement for OSHA safety training for public works projects.

The County is required to obtain certification that the bidder awarded the attached contract participates in a federal work authorization program. To obtain additional information on the Department of Homeland Security's E-Verify program, go to:

[http://www.uscis.gov/portal/site/uscis/menuitem/ep\\_eb1d4c2a3e3b9ac89243e6a7543f6d1a?vgnextoid=75bce2e261405110VgnVCM1000004718190aRCRD&vgnextchannel=75bce2e261405110VgnVCM1000004718190aRCRD](http://www.uscis.gov/portal/site/uscis/menuitem/ep_eb1d4c2a3e3b9ac89243e6a7543f6d1a?vgnextoid=75bce2e261405110VgnVCM1000004718190aRCRD&vgnextchannel=75bce2e261405110VgnVCM1000004718190aRCRD)

Please complete and return form *Work Authorization Certification Pursuant to 285.530 RSMo* if your contract amount is in excess of \$5,000. **Attach to this form the first and last page of the *E-Verify Memorandum of Understanding* that you completed when enrolling.**



N/A

**AFFIDAVIT**  
**(Only Required for Individual Bidder Certification Option #2)**

State of Missouri                    )  
  )SS.  
County of \_\_\_\_\_            )

I, the undersigned, being at least eighteen years of age, swear upon my oath that I am either a United States citizen or am classified by the United States government as being lawfully admitted for permanent residence.

\_\_\_\_\_  
Date

\_\_\_\_\_  
Signature

\_\_\_\_\_  
Social Security Number  
or Other Federal I.D. Number

\_\_\_\_\_  
Printed Name

On the date above written \_\_\_\_\_ appeared before me and swore that the facts contained in the foregoing affidavit are true according to his/her best knowledge, information and belief.

\_\_\_\_\_  
Notary Public

My Commission Expires:

(Please complete and return with Bid)

Certification Regarding  
Debarment, Suspension, Ineligibility and Voluntary Exclusion  
Lower Tier Covered Transactions

This certification is required by the regulations implementing Executive Order 12549, Debarment and Suspension, 29 CFR Part 98 Section 98.510, Participants' responsibilities. The regulations were published as Part VII of the May 26, 1988, Federal Register (pages 19160-19211).

(BEFORE COMPLETING CERTIFICATION, READ INSTRUCTIONS FOR CERTIFICATION)

- (1) The prospective recipient of Federal assistance funds certifies, by submission of this proposal, that neither it nor its principals are presently debarred, suspended, proposed for debarment, declared ineligible, or voluntarily excluded from participation in this transaction by any Federal department or agency.
- (2) Where the prospective recipient of Federal assistance funds is unable to certify to any of the statements in this certification, such prospective participant shall attach an explanation to this proposal.

TERESA C. EDWARDS, PRESIDENT  
Name and Title of Authorized Representative

Teresa C. Edwards  
Signature

12 4 2015  
Date

ANTI-COLLUSION STATEMENT

STATE OF MISSOURI

COUNTY OF Jackson

TERESA C. EDWARDS, being first duly sworn, deposes and

says that he is PRESIDENT  
(Title of Person Signing)

of SPECTRUM ANTENNA SERVICES, INC  
(Name of Bidder)

that all statements made and facts set out in the proposal for the above project are true and correct; and the bidder (person, firm, association, or corporation making said bid) has not, either directly or indirectly, entered into any agreement, participated in any collusion, or otherwise taken any action in restraint of free competitive bidding in connection with said bid or any contract which may result from its acceptance.

Affiant further certifies that bidder is not financially interested in, or financially affiliated with, any other bidder for the above project.

By Teresa C Edwards By \_\_\_\_\_

By \_\_\_\_\_

MAUDE-LOUISE GREGG  
NOTARY PUBLIC-NOTARY SEAL  
STATE OF MISSOURI  
COMMISSIONED FOR JACKSON COUNTY  
COMMISSION EXPIRES MAY 5, 2017  
ID # 13405072

Sworn to before me this 4<sup>th</sup> day of December, 2015

Maude-Louise Gregg  
Notary Public

My Commission Expires May 5, 2017

**SIGNATURE AND IDENTITY OF BIDDER**

The undersigned states that the correct LEGAL NAME and ADDRESS of (1) the individual Bidder, (2) each partner or joint venture (whether individuals or corporations, and whether doing business under fictitious name), or (3) the corporation (with the state in which it is incorporated) are shown below; that (if not signing with the intention of binding himself to become the responsible and sole Contractor) he is the agent of, and duly authorized in writing to sign for the Bidder or Bidders; and that he is signing and executing this (as indicated in the proper spaces below) as the proposal of a:

sole individual                       partnership                       joint venture  
 corporation, incorporated under laws of the state of MISSOURI

Dated 12.4, 20 15

Name of individual, all partners, or joint venturers:

Address of each:

TERESA C EDWARDS

220 LAKOTA LN LS MO 64086

JEFF D. EDWARDS

220 LAKOTA LN LS MO 64086

Address of principal place of business in doing business under the name of:

SPECTRUM ANTENNA SERVICES INC, 220 LAKOTA LN LS MO 64086  
(If using a fictitious name, show this name above in addition to legal names.)

(If a corporation – show its name above)

ATTEST:  
Maudie-Louise Gregg  
(Secretary)

Blue Ridge Bank Asst. Br. Mgr  
(Title)

NOTE: If the Bidder is doing business under a FICTITIOUS NAME, the Proposal shall be executed in the legal name of the individual, partners, joint venturers, or corporation, with the legal address shown, and the REGISTRATION OF FICTITIOUS NAME filed with the Secretary of State, as required by Section 417.200 to 417.230, RS Mo. shall be attached. If the Bidder is a CORPORATION NOT ORGANIZED UNDER THE LAWS OF MISSOURI, it shall procure a CERTIFICATE OF AUTHORITY TO DO BUSINESS IN MISSOURI, as required by Section 351.570 and following, RS Mo. A CERTIFIED COPY of such Registration of Fictitious Name or Certificate of Authority to do Business in Missouri shall be filed with the Engineer.

**BIDDER'S ACKNOWLEDGMENT**

(Complete and fill out all parts applicable, and strike out all parts not applicable.)

State of Missouri County of Jackson

On this 4<sup>th</sup> day of DECEMBER, 20 15

before me appeared TERESA C. EDWARDS to me personally known, who, being by me first duly sworn, did say that he executed the foregoing Proposal with full knowledge and understanding of all its terms and provisions and of the plans and specifications; that the correct legal name and address of the Bidder (including those of all partners of joint ventures if fully and correctly set out above; that all statements made therein by or for the Bidder are true; and (if a sole individual) acknowledged that he executed the same as his free act and deed.

(if a partnership or joint venture) acknowledged that ~~he~~ executed same, with written authority from, and as the free act and deed of, all said partners or joint ventures.

(if a corporation) that he is the PRESIDENT, Teresa C. Edwards  
President or other agent

of SPECTRUM HOTEL SERVICES INC. that the above Proposal was signed and sealed in behalf of said corporation by authority of its board of directors; and he acknowledged said proposal to be the free act and deed of said corporation.

Witness my hand and seal at Blue Ridge Bank the day and year first above written. (SEAL).

Maude Louise Gregg

Notary Public MAUDE-LOUISE GREGG  
NOTARY PUBLIC-NOTARY SEAL  
STATE OF MISSOURI  
COMMISSIONED FOR JACKSON COUNTY  
COMMISSION EXPIRES MAY 5, 20  
ID # 13405072

My Commission expires May 5, 20 17





WORK AUTHORIZATION CERTIFICATION  
PURSUANT TO 285.530 RSMo  
(FOR ALL AGREEMENTS IN EXCESS OF \$5,000.00)

County of Jackson  
State of MO )ss  
)

My name is Teresa Edwards. I am an authorized agent of Spectrum Antenna Services, INC (Bidder). This business is enrolled and participates in a federal work authorization program for all employees working in connection with services provided to the County. This business does not knowingly employ any person that is an unauthorized alien in connection with the services being provided. Documentation of participation in a federal work authorization program is attached hereto.

Furthermore, all subcontractors working on this contract shall affirmatively state in writing in their contracts that they are not in violation of Section 285.530.1, shall not thereafter be in violation and submit a sworn affidavit under penalty of perjury that all employees are lawfully present in the United States.

Teresa C. Edwards 10.13.2015  
Affiant Date

TERESA C. EDWARDS  
Printed Name

Subscribed and sworn to before me this 13 day of October, 2015

Gabriella V. Barrett  
Notary Public



Attach to this form the first and last page of the *E-Verify Memorandum of Understanding* that you completed when enrolling.



Company ID Number: 453610

THE E-VERIFY PROGRAM FOR EMPLOYMENT VERIFICATION  
MEMORANDUM OF UNDERSTANDING

ARTICLE I

PURPOSE AND AUTHORITY

This Memorandum of Understanding (MOU) sets forth the points of agreement between the Department of Homeland Security (DHS) and Spectrum Antenna Services, Inc. (Employer) regarding the Employer's participation in the Employment Eligibility Verification Program (E-Verify). This MOU explains certain features of the E-Verify program and enumerates specific responsibilities of DHS, the Social Security Administration (SSA), and the Employer. E-Verify is a program that electronically confirms an employee's eligibility to work in the United States after completion of the Employment Eligibility Verification Form (Form I-9). For covered government contractors, E-Verify is used to verify the employment eligibility of all newly hired employees and all existing employees assigned to Federal contracts or to verify the entire workforce if the contractor so chooses.

Authority for the E-Verify program is found in Title IV, Subtitle A, of the Illegal Immigration Reform and Immigrant Responsibility Act of 1996 (IIRIRA), Pub. L. 104-208, 110 Stat. 3009, as amended (8 U.S.C. § 1324a note). Authority for use of the E-Verify program by Federal contractors and subcontractors covered by the terms of Subpart 22.18, "Employment Eligibility Verification", of the Federal Acquisition Regulation (FAR) (hereinafter referred to in this MOU as a "Federal contractor with the FAR E-Verify clause") to verify the employment eligibility of certain employees working on Federal contracts is also found in Subpart 22.18 and in Executive Order 12989, as amended.

ARTICLE II

FUNCTIONS TO BE PERFORMED

A. RESPONSIBILITIES OF SSA

1. SSA agrees to provide the Employer with available information that allows the Employer to confirm the accuracy of Social Security Numbers provided by all employees verified under this MOU and the employment authorization of U.S. citizens.
2. SSA agrees to provide to the Employer appropriate assistance with operational problems that may arise during the Employer's participation in the E-Verify program. SSA agrees to provide the Employer with names, titles, addresses, and telephone numbers of SSA representatives to be contacted during the E-Verify process.
3. SSA agrees to safeguard the information provided by the Employer through the E-Verify program procedures, and to limit access to such information, as is appropriate by law, to individuals responsible for the verification of Social Security Numbers and for evaluation of the E-Verify program or such other persons or entities who may be authorized by SSA as governed



Company ID Number: 453610

North American Industry Classification Systems Code:	238
Administrator:	
Number of Employees:	1 to 4
Number of Sites Verified for:	1
<b>Are you verifying for more than 1 site? If yes, please provide the number of sites verified for in each State:</b>	
• MISSOURI	1 site(s)

Information relating to the Program Administrator(s) for your Company on policy questions or operational problems:

Name:	Teresa C Edwards	Fax Number:	(816) 697 - 3681
Telephone Number:	(816) 697 - 3680		
E-mail Address:	monopole@wans.net		

(Please complete and return with Bid)

Certification Regarding  
Debarment, Suspension, Ineligibility and Voluntary Exclusion  
Lower Tier Covered Transactions

This certification is required by the regulations implementing Executive Order 12549, Debarment and Suspension, 29 CFR Part 98 Section 98.510, Participants' responsibilities. The regulations were published as Part VII of the May 26, 1988, Federal Register (pages 19160-19211).

(BEFORE COMPLETING CERTIFICATION, READ INSTRUCTIONS FOR CERTIFICATION)

- (1) The prospective recipient of Federal assistance funds certifies, by submission of this proposal, that neither it nor its principals are presently debarred, suspended, proposed for debarment, declared ineligible, or voluntarily excluded from participation in this transaction by any Federal department or agency.
- (2) Where the prospective recipient of Federal assistance funds is unable to certify to any of the statements in this certification, such prospective participant shall attach an explanation to this proposal.

TERESA C. EDWARDS, PRESIDENT  
Name and Title of Authorized Representative

Teresa C Edwards  
Signature

10.15.2015  
Date





**Boone County Purchasing**  
613 E. Ash Street, Room 110  
Columbia, Mo 65201

## **REQUEST FOR BID (RFB)**

Melinda Bobbitt, CPPO, CPPB  
Director of Purchasing  
(573) 886-4393 – Fax: (573) 886-4390  
Email: [mbobbitt@boonecountymo.org](mailto:mbobbitt@boonecountymo.org)

---

### ***Bid Data***

Bid Number: **77-10DEC15**  
Commodity Title: **Radio Tower Erection for Battle School Project**

### **DIRECT ANY BID FORMAT OR SUBMISSION QUESTIONS TO PURCHASING DEPT.**

### ***Bid Submission Address and Deadline***

Day/Date: Thursday, December 10, 2015  
Time: 1:00 p.m. (Bids received after this time will be returned unopened)  
Location/Mail Address: Boone County Purchasing Department  
Boone County Annex Building  
613 E. Ash, Room 110  
Columbia, Mo 65201  
Directions: Annex Building is located at corner of 7<sup>th</sup> & Ash St.

### ***Bid Opening***

Day/Date: Thursday, December 10, 2015  
Time: 1:30 p.m., Central Time  
Location/Address: Boone County Government Center  
Commission Chambers  
801 E. Walnut Street  
Columbia, MO 65201

### ***Bid Contents***

1.0: Introduction and General Conditions of Bidding  
2.0: Primary Specifications  
3.0: Response Presentation and Review  
4.0: Response Form  
Attachments: Statement of Bidder's Qualifications  
Standard Terms and Conditions  
Instructions for House Bill 1549  
Work Authorization Certification  
Individual Bidder Affidavits  
Debarment Form  
Anti-Collusion Statement

*Bid Contents, continued*

---

Signature & Identify of Bidder  
Bidder's Acknowledgement  
Annual Wage Order #22, dated 10/20/15  
Affidavit of Compliance with OSHA  
Affidavit of Compliance with Prevailing Wage Law  
"No Bid" Response Form

## **1. Introduction and General Conditions of Bidding**

**1.1. INVITATION** – The County of Boone, through its Purchasing Department, invites responses, which offer to provide the goods and/or services identified on the title page, and described in greater detail in Section 2.

### **1.2. DEFINITIONS**

**County** – This term refers to the County of Boone, a duly organized public entity. It may also be used as a pronoun for various subsets of the County organization, including, as the context will indicate:

*Purchasing* – The Purchasing Department, including its Purchasing Director and staff.

*Department/s or Office/s* – The County Department/s or Office/s for which this Bid is prepared, and which will be the end user/s of the goods and/or services sought.

*Designee* – The County employee/s assigned as your primary contact/s for interaction regarding Contract performance.

**Bidder / Contractor / Supplier** – These terms refer generally to businesses having some sort of relations to or with us. The term may apply differently to different classes of entities, as the context will indicate.

*Bidder* – Any business entity submitting a response to this Bid. Suppliers, which may be invited to respond, or which express interest in this bid, but which do not submit a response, have no obligations with respect to the bid requirements.

*Contractor* – The Bidder whose response to this bid is found by Purchasing to meet the best interests of the County. The Contractor will be selected for award, and will enter into a Contract for provision of the goods and/or services described in the Bid.

*Supplier* – All business/entities which may provide the subject goods and/or services.

**Bid** – This entire document, including attachments. A Bid may be used to solicit various kinds of information. The kind of information this Bid seeks is indicated by the title appearing at the top of the first page. A “Request for Bid” is used when the need is well defined. A “Request for Proposal” is used when the County will consider solutions, which may vary significantly from each other or from the County’s initial expectations.

**Response** – The written, sealed document submitted according to the Bid instructions.

**1.3. BID CLARIFICATION** – Questions regarding this Bid should be directed in writing, preferably by e-mail, to the Purchasing Department. Answers, citing the question asked but not identifying the questioner, will be distributed simultaneously to all known prospective Bidders. Note: written requirements in the Bid or its Addenda are binding, but any oral communications between County and Bidder are not.

**1.4. Bidder Responsibility** – The Bidder is expected to be thoroughly familiar with all specifications and requirements of this Bid. Bidder’s failure or omission to examine any relevant form, article, site or document will not relieve them from any obligation regarding this Bid. By submitting a Response, Bidder is presumed to concur with all terms, conditions and specifications of this Bid.

**1.5. Bid Addendum** – If it becomes evident that this Bid must be amended, the Purchasing Department will issue a formal written Addendum to all known prospective Bidders. If necessary, a new due date will be established.

**1.6. AWARD** – Award will be made to the Bidder/s whose offer/s provide the greatest value to the County from the standpoint of suitability to purpose, quality, service, previous experience, price, lifecycle cost, ability to deliver, or for any other reason deemed by Purchasing to be in the best interest of the County. Thus, the result will not be determined by price alone. The County will be seeking the least costly outcome that meets the County needs as interpreted by the County.

**1.7. CONTRACT EXECUTION** – This Bid and the Contractor’s Response will be made part of any resultant Contract and will be incorporated in the Contract as set forth, verbatim.



**Precedence** – In the event of contradictions or conflicts between the provisions of the documents comprising this Contract, they will be resolved by giving precedence in the following order:

- 1) the provisions of the Contract (as it may be amended);
- 2) the provisions of the Bid;
- 3) the provisions of the Bidder's Response.

**1.8. COMPLIANCE WITH STANDARD TERMS AND CONDITIONS** – Bidder agrees to be bound by the County's standard "boilerplate" terms and conditions for Contracts, a sample of which is attached to this Bid.

## **2. Primary Specifications**

### **ITEMS TO BE PROVIDED**

#### **1.00 GENERAL**

1.01 Vendor to provide all materials, machinery, equipment and services to completely assemble and erect a monopole radio tower in accordance with these specifications, manufacturer approved drawings and practices, and all applicable EIA specifications.

1.02 Vendor shall work with County's representative and Sabre Industries to coordinate delivery of monopole tower. Vendor shall be responsible to contract and pay for crane to unload, stow, and erect tower steel at site.

1.03 County will secure necessary FAA, FCC and local zoning clearances and authority.

1.04 Vendor will be responsible for obtaining all required work permits.

1.05 Vendor personnel must satisfy background checking as required by Columbia Public Schools. Vendor shall complete background application forms and receive approval from CPS prior to start of work.

1.06 There is no electrical service at the site. Vendor must furnish generator power if needed for tower erection.

1.07 All parts, materials, supplies and services will meet the minimum construction and erection standards recommended by Sabre Industries, the tower manufacturer.

1.08 Vendor shall utilize tower materials furnished by Sabre Industries, the tower manufacturer. Any other materials, fastenings, hardware or supplies proposed for use on the project shall receive approval by County's representative prior to installation.

1.09 On a daily basis, Vendor shall leave the site clear of construction debris, excess material or unused supplies or equipment including cans, crates, boxes, plastic bags, bolt cartons or any rubbish resulting from the work. Following completion of erection work, Vendor will transport all surplus and excess materials and supplies provided by tower manufacturer to County's storage area.

1.10 Vendor will have free access to the tower site. County will provide list of project contact people for Vendor's use.

1.11 After completion, tower will be jointly inspected by the Vendor and County's representative. Any required corrections shall be made immediately.

1.12 Detailed installation diagrams and documents shall be provided by County to Vendor. Following completion of the tower erection, all documents shall be returned to County.

1.13 Tower shall be designed and fabricated so that erection may be accomplished using tensioning hoists and bolts for slip sections. Any bolt-on section tensioning brackets necessary for manufacturer-

recommended assembly shall be furnished with tower. Erection shall be accomplished using bolts and provided hardware with no field welding, cutting, or drilling required or allowed.

1.14 Any damage to the galvanizing will be touched up with Z.R.C. Cold Galvanizing Compound or approved equivalent.

1.15 Vendor shall be limited to work occurring between 7:00AM and 7:00PM local time.

1.16 The site is presently operating with a temporary ground-mounted antenna. An equipment shelter is in place and an engine-generator and its LP fuel tank serve the compound. Vendor shall ensure that his work will not interfere with ongoing site operations or cause any damage to site components or site equipment.

## **2.00 TOWER COMPONENTS**

2.01 Refer to attached design and erection drawings of the details of the tower.

2.02 The tower is a nominal 170' monopole. Assembly will include (at least) the following major attachments:

- Top-mounted nominal 12' face platform with handrails and antenna pipes
- Side mounted antenna bracket at nominal 100' level
- Side mounted antenna bracket at nominal 75' level
- Side mounted antenna brackets (three) at nominal 20' level

2.03 Safety-climb device will be mounted centered on the tower between climbing pegs.

## **3.00 ATTACHMENTS**

3.01 All attachments shall be considered a part of this specification.

3.02 Attachments include:

- Electronic copy of detailed erection drawings as furnished by tower manufacturer.
- General site layout

## **4.00 SUBMITTALS**

4.01 In addition to required bid documents, Vendor will also submit the following:

- Proposed general approach to project work.
- Demonstrated qualifications to complete the project including references for similar towers.

**5.00 Debarment and Suspension:** By submission of its Bid Response, Vendor agrees to comply with the provisions of Executive Order 12549, regarding Debarment and Suspension. Specifically, the Vendor certifies that neither he/she nor their principals are 1.) presently debarred, suspended, proposed for debarment, declared ineligible or voluntary excluded from covered transactions by a Federal department or agency, 2) have not with a three year period preceding this proposal been convicted of or had a civil judgment rendered against them for commission of fraud or a criminal offense in connection with obtaining, attempting to obtain or performing a public transaction or contract under a public transaction;

violation of Federal or State antitrust statutes or commission of embezzlement, theft, forgery, bribery, falsification or destruction of records, making false statements or receiving stolen property; 3.) are not presently indicted for or otherwise criminal or civilly charged by a government entity with commission of any of the offenses stated above and 4.) have not within a three year period preceding this bid had one or more public transactions terminated for cause or default.

**6.00 Certification of Non-Resident/Foreign Contractors:** If the Contractor is a foreign corporation or nonresident Contractor, it is agreed that the Contractor shall procure and maintain during the life of this contract:

- A. A certificate of authority to transact business in the State of Missouri from the Secretary of State, unless exempt pursuant to the provisions of Section 351.572 RSMo.
- B. A certificate from the Missouri Director of Revenue evidencing compliance with transient employer financial assurance law, unless exempt pursuant to the provisions of Section 285.230 RSMo.

**7.00 Insurance Requirements** - The Contractor shall not commence work under this contract until they have obtained all insurance required under this paragraph and the Certificate of Insurance has been approved by the County, nor shall the Contractor allow any subcontractor to commence work on their subcontract until all similar insurance required of subcontractor has been so obtained and approved. All policies shall be in amounts, form and companies satisfactory to the County which must carry an A-6 or better rating as listed in the A.M. Best or equivalent rating guide. Insurance limits indicated below may be lowered at the discretion of the County.

- A. Employers Liability and Workers Compensation Insurance** - The Contractor shall take out and maintain during the life of this contract, **Employers Liability and Workers Compensation Insurance** for all of its employees employed at the site of work. and in case any work is sublet, the Contractor shall require the subcontractor similarly to provide Workers Compensation Insurance for all of the latter's employees unless such employees are covered by the protection afforded by the Contractor. Workers Compensation coverage shall meet Missouri statutory limits. Employers Liability limits shall be \$500,000.00 each employee, \$500,000.00 each accident, and \$500,000.00 policy limit. In case any class of employees engaged in hazardous work under this Contract at the site of the work is not protected under the Workers Compensation Statute, the Contractor shall provide and shall cause each subcontractor to provide Employers Liability Insurance for the protection of their employees not otherwise protected.
- B. Commercial General Liability Insurance** - The Contractor shall take out and maintain during the life of this contract, such commercial general liability insurance as shall protect it and any subcontractor performing work covered by this contract, from claims for damages for personal injury including accidental death, as well as from claims for property damages, which may arise from operations under this contract, whether such operations be by themselves or for any subcontractor or by anyone directly or indirectly employed by them. The amounts of insurance shall be not less than \$3,000,000.00 combined single limit for any one occurrence covering both bodily injury and property damage, including accidental death. If the Contract involves any underground/digging operations, the general liability certificate shall include X, C, and U (Explosion, Collapse, and Underground) coverage. If providing Commercial General Liability Insurance, then the Proof of Coverage of Insurance shall also be included.
- C.** Contractor may satisfy the minimum liability limits required for Commercial General Liability or Business Auto Liability under an Umbrella or Excess Liability policy. There is no minimum per occurrence limit of liability under the umbrella or Excess Liability; however, the Annual Aggregate limit shall not be less than the highest "Each Occurrence" limit for either Commercial

General Liability or Business Auto Liability. Contractor agrees to endorse the County as an Additional Insured on the umbrella or Excess Liability, unless the Certificate of Insurance state the Umbrella or Excess Liability provides coverage on a "Follow-Form" basis.

- D. Business Automobile Liability** – The Contractor shall maintain during the life of this contract, automobile liability insurance in the amount of not less than \$3,000,000.00 combined single limit for any one occurrence, covering both bodily injury, including accidental death, and property damage, to protect themselves from any and all claims arising from the use of the Contractor's own automobiles, teams and trucks; hired automobiles, teams and trucks; non-owned and both on and off the site of work.
- E. Subcontractors:** Contractor shall cause each Subcontractor to purchase and maintain insurance of the types and amounts specified herein. Limits of such coverage may be reduced only upon written agreement of County. Contractor shall provide to County copies of certificates of insurance evidencing coverage for each Subcontractor. Subcontractors' commercial general liability and business automobile liability insurance shall name County as Additional Insured and have the Waiver of Subrogation endorsements added.
- F. Proof of Carriage of Insurance** - The Contractor shall furnish the County with Certificate(s) of Insurance which name the County as additional insured in an amount as required in this contract, contain a description of the project or work to be performed and provided for Commercial General Liability, Business Auto Liability, and Umbrella or Excess Liability (not on Workers Compensation). The Certificate of Insurance shall provide that there will be no cancellation, non-renewal or reduction of coverage without 30 days prior written notice to the Owner. In addition, such insurance shall be on an occurrence basis and shall remain in effect until such time as the County has made final acceptance of the services provided.
- G. INDEMNITY AGREEMENT:** To the fullest extent permitted by law, Contractor shall indemnify, hold harmless and defend the County, its directors, officers, agents, and employees from and against all claims, damages, losses and expenses (including but not limited to attorney's fees) arising by reason of any act or failure to act, negligent or otherwise, of Contractor, of any subcontractor (meaning anyone, including but not limited to consultants having a contract with contractor or a subcontract for part of the services), of anyone directly or indirectly employed by contractor or by any subcontractor, or of anyone for whose acts the contractor or its subcontractor may be liable, in connection with providing these services. This provision does not, however, require contractor to indemnify, hold harmless, or defend the County of Boone from its own negligence.
- H.** Failure to maintain the required insurance in force may be cause for contract termination. In the event the Agency/Service fails to maintain and keep in force the required insurance or to obtain coverage from its subcontractors, the County shall have the right to cancel and terminate the contract without notice.

**8.00 Sales/Use Tax Exemption:** County will provide the Contractor with a completed Missouri Project Exemption and Missouri Tax Exemption letter for Boone County, Missouri and the Contractor shall be responsible for furnishing the exemption certificate and tax exemption letter to all authorized sub-contractors and suppliers providing materials incorporated in the work. All invoices issued for purchases for such materials, supplies and taxable rentals shall be in the name of Boone County and contain the project number assigned by Boone County for the contract awarded. It shall be the responsibility of the Contractor to insure that no sales or use taxes are included in the invoices and that the County pays no sales/use taxes from which it is exempt. The Contractor shall be responsible for obtaining revised

exemption certificates and revised expiration dates if the work extends beyond the estimated project completion date or a certificate expiration date. The Contractor shall also be responsible for retaining a copy of the project exemption certificate for a period of five years and for compliance with all other terms and conditions of section 144.062 RSMo. Not otherwise herein specified. The Contractor agrees not to use or permit others to use the project exemption certificate for taxable purchases of materials or rentals and supplies not directly incorporated into or used in the work to which it applies and agrees to indemnify and hold the County harmless from all losses, expenses and costs including litigation expenses and attorney fees resulting from the unauthorized use of such project exemption certificates.

**9.00 Warranty & Guarantee** - Contractor warrants and guarantees to Owner that all work will be in accordance with the Contract Documents and will not be defective. All materials provided by the Contractor shall be new material of high quality which shall give long life and reliable operation. The workmanship shall be of high quality in every detail. Prompt notice of all defects shall be given to Contractor. All defective work, whether or not in place, may be rejected, corrected, or accepted as follows:

*Correction or Removal of Defective Work*- If required by Owner, Contractor shall promptly, as directed, either correct all defective Work, whether or not fabricated, installed or completed, or if the Work has been rejected by County Department Designee, remove it from the site and replace it with non-defective Work. Contractor shall bear all direct, indirect, and consequential costs of such correction or removal (including but not limited to fees and charges of engineers, architects, attorneys, and other professionals made necessary thereby).

*One Year Correction Period*- If within one year after the date of Substantial Completion or such longer period of time as may be prescribed by Laws or Regulations or by the terms of any applicable special guarantee required by the Contract Documents or by any specific provision of the Contract Documents, any Work is found to be defective, Contractor shall promptly, without cost to Owner and in accordance with Owner's written instructions, either correct such defective Work, or if it has been rejected by Owner, remove it from the site and replace it with non-defective Work. If Contractor does not promptly comply with the terms of such instructions or in an emergency where delay would cause serious risk of loss or damage, Owner may have the defective Work removed and replaced and all direct, indirect, and consequential costs of removal and replacement (including but not limited to fees and charges of engineers, architects, attorneys, and other professionals) will be paid by the Contractor. In special circumstances where a particular item of equipment is placed in continuous service before Substantial Completion of all the Work, the correction period for that item may start to run from an earlier date if so provided in the Specifications or by Written Amendment.

**10.00 Prevailing Wage:** Contractor agrees that it will pay not less than the prevailing hourly rate of wages to all workmen performing work under the Contract in accordance with the prevailing wage determination issued by the Division of Labor Standards of the Department of Labor and Industrial Relations for the State of Missouri and as maintained on file with the Boone County Purchasing Department. The Contractor shall comply with all requirements of the prevailing wage law of Missouri, Revised Statutes of Missouri, Sections 290.210 to 290.340, including the latest amendments thereto. The prevailing wage law does not prohibit payment of more than the prevailing rate of wages nor does it limit the hours of work which may be performed by any worker in any particular period of time. The Contractor further agrees that it shall forfeit as a penalty to the County of Boone the sum of \$100.00 for each workman employed for each calendar day or portion thereof such workman is paid less than the stipulated rates set forth in the prevailing wage determination for the project for any work done under this contract by the Contractor pursuant to the provisions of Section 290.250 RSMo. The Contractor further agrees that he will abide by all provisions of the prevailing wage law as set forth in Chapter 290 RSMo and rules and regulations issued thereunder and that any penalties assessed may be withheld from sums due to the Contractor by the Owner.

The Contractor and all Subcontractors shall be required to submit to the designated representative of the County using department, certified copies of labor payrolls and statements of compliance (Form WH-347) for each week that work is in progress. If work is temporarily suspended, the last payroll shall be marked appropriately to note that it will be the last payroll until work is resumed.

Contractor shall be responsible for the submittal of payrolls and certifications for all subcontractors. Contractor shall keep an accurate record showing the names, occupations, and crafts of all workers employed, together with the number of hours worked by each worker and the actual wages paid to each worker. At all reasonable hours, such records shall be open to inspection by the representatives of Industrial Commission of Missouri and the County. The payroll records shall not be destroyed or removed from the State for at least one year after completion of the work.

The County will check payrolls, with the following checks being made to insure proper labor compliance:

- a. The employee's full name as shown on his/her social security card, his address and Employee I.D. number shall be entered on each payroll.
- b. Check the payroll for correct employee classification.
- c. Check payroll for correct hourly wage and, if applicable, correct overtime hourly rate.
- d. Check the daily and weekly hours worked in each classification including actual overtime hours worked (not adjusted hours).
- e. All deductions are shown in the net wage shown. The Form WH-437 is to be used if fringe benefits are paid into established programs. However, if fringe benefits are paid in cash to the employee, the amount shall be indicated on the payroll.
- f. All checking by the County will be made in red pencil and initialed by the checker.
- g. Final payroll will be marked "Final" or "last Payroll".
- h. A record of all payrolls will be maintained by the County.

Throughout the life of the Contract, a copy of the wage determination and the rules promulgated by the Industrial Commission of Missouri shall be displayed in at least one conspicuous place on the project under a heading NOTICE with the heading in letters at least one inch high.

After completion of the work and before final payment can be made under this contract, the Contractor must file with the County an affidavit stating that they have fully complied with the provisions and requirements of the prevailing wage law of Missouri, Sections 290.210 to 290.340 RSMo. The prevailing wage rate determination made by the Industrial Commission of Missouri is reproduced verbatim and is applicable to this contract whenever Boone County provides to Contractor a project which is determined to be applicable to prevailing wage law

**11.00 EXTRA AND/OR ADDITIONAL WORK AND CHANGES:** If any extra and/or additional work is to be done or any change in the plans and specifications is deemed necessary, the County may issue to the Contractor a written change order directing that such extra and/or additional work be done or that such change be made, and the Contract shall be modified accordingly. Compensation to the Contractor will be calculated as an addition to or deduction from the Contract price, based upon such written terms as may be established by the owner, either (a) by an acceptable lump sum proposal of the Contractor, (b) on a cost-plus limited basis not to exceed a specified limit, or (c) on basis of bid or mutually agreed upon unit prices. In the event that none of the foregoing methods are agreed upon with the Contractor, the County may perform the work with its own forces or under separate contract with another contractor.

**12.00 DISCHARGE OF EMPLOYEES:** Any employee of the Contractor who is stationed at the site of the work and should prove to be quarrelsome, dishonest, incompetent or inexperienced, or should not work for the good of the job shall, upon written notice from the County, be removed by the Contractor and replaced by an employee with proper qualifications.

**13.00 SUBCONTRACTORS, SUPPLIERS AND OTHERS-** Contractor shall not employ any Subcontractor, Supplier, or other person or organization (including those acceptable to Owner as indicated below), whether initially or as a substitute, against whom Owner may have reasonable objection. Contractor shall not be required to employ any Subcontractor, Supplier, or other person or organization to furnish or perform any of the Work against whom the Contractor has a reasonable objection.

If the Owner requires identity of certain Subcontractors, Suppliers, or other persons or organizations (including those who are to furnish the principal items of material and equipment) to be submitted to Owner in advance of the specified date prior to the Effective Date of the Agreement for acceptance by Owner and if Contractor has submitted a list thereof in accordance with the project Specifications, Owner's acceptance (either in writing or by failing to make written objection thereto by the date indicated for acceptance or objection in the bidding documents or the Contract Documents) of any such Subcontractor, Supplier, or other person or organization so identified may be revoked on the basis of reasonable objection after due investigation, in which case Contractor shall submit an acceptable substitute, the Contract Price will be increased by the difference in the cost occasioned by such substitution and an appropriate Change Order will be issued or Written Amendment signed. No acceptance by Owner of any such Subcontractor, Supplier, or other person or organization shall constitute a waiver of any right of Owner to reject defective Work.

**14.00 ACCIDENT PREVENTION:** Precaution shall be exercised at all times for the protection of persons (including employees) and property. The safety provisions of applicable laws, building and construction codes shall be observed. Machinery, equipment, and all hazards shall be guarded or eliminated in accordance with the safety provisions of the Manual of Accident Prevention in Construction, 8th Edition, 1999, published by the Associated General Contractors of America, to the extent that such provisions are not in contravention of applicable laws. Current standards of the Occupational Safety and Health Act shall be applied, as well as the requirements contained within the current MUTCD.

**15.00 LEGAL REQUIREMENTS:** The Contractor shall do all work in such manner as to comply with all County ordinances, and laws of the County, State, and Nation as apply to the work herein outlined. The Contractor shall also obtain all necessary licenses and permits and keep necessary records as required.

**16.00 EQUAL OPPORTUNITY:** The County of Boone is an equal opportunity affirmative action employer, pursuant to federal and state law, and all respondents submitting bids shall be considered to be EEO/AA employers in compliance with federal and state laws, unless otherwise stipulated by the bidders herein.

The Contractor agrees that he will comply with all federal and state laws and regulations and local ordinances and that he will comply and cause each of his subcontractors, and directives pertaining to nondiscrimination against any person on the grounds of race, color, religion, creed, sex, age, ancestry, or national origin in connection with this Contract, including procurement of materials and lease of equipment; therefore, in accordance with the special provisions on that subject attached hereto, incorporated in and made a part of the Contract.



**17.00 DOMESTIC PURCHASING POLICY:** Contractors are encouraged to select and use materials manufactured, assembled, or produced in the United States in the performance of this contract whenever the quality and price are comparable with other goods. By submission of this bid, the vendor certifies that they are in compliance with section 34.353 and, if applicable, section 34.359 (“Missouri Domestic Products Procurement Act”) of the Revised Statutes of Missouri, 1987.

**18.00 TRANSIENT EMPLOYERS:** Every transient employer, as defined in Section 285.230 RSMo, must post in a prominent and easily accessible place at the work site a clearly legible copy of the following: (1) the notice of registration for employer withholding issued to such transient employer by the director of revenue; (2) proof of coverage for workers' compensation insurance or self-insurance signed by the transient employer and verified by the department of revenue through the records of the division of workers' compensation; and (3) the notice of registration for unemployment insurance issued to such transient employer by the division of employment security. Any transient employer failing to comply with these requirements shall, under Section 285.234 RSMo, be liable for a penalty of five hundred dollars per day until the notices required by this section are posted as required by law.

**19.00 PROTECTION OF WORK:** The Contractor shall take all necessary steps to protect his own workers, the utility personnel, and the public from unnecessary danger or hazard during the prosecution of this work. Danger signs, warning signs, flares, lanterns, railings, barriers, sheeting, shoring, etc, shall be erected to prevent accidents from construction, falling objects, rotating machinery, electric lines and other conditions which might prevent unusual hazard.

**20.00 OVERHEAD LINE PROTECTION:** The Contractor is aware of the provisions of the Overhead Power Line Safety Act, 319.075 to 319.090 RSMo, and agrees to comply with the provisions thereof. Contractor understands that it is their duty to notify any utility operating high voltage overhead lines and make appropriate arrangements with said utility if the performance of contract would cause any activity within ten feet of any high voltage overhead line. To the fullest extent permitted by law, Contractor shall indemnify, hold harmless and defend the County, its directors, officers, agents, and employees from and against all claims, damages, losses and expenses (including but not limited to attorney’s fees) arising by reason of any act or failure to act, negligent or otherwise, of Contractor, of any subcontractor (meaning anyone, including but not limited to consultants having a contract with contractor or a subcontract for part of the services), of anyone directly or indirectly employed by contractor or by any subcontractor, or of anyone for whose acts the contractor or its subcontractor may be liable, in connection with any claims arising under the Overhead Power Line Safety Act. Contractor expressly waives any action for Contribution against the County on behalf of the Contractor, any subcontractor (meaning anyone, including but not limited to consultants having a contract with contractor or a subcontract for part of the services), anyone directly or indirectly employed by contractor or by any subcontractor, or of anyone for whose acts the contractor or its subcontractor may be liable, and agrees to provide a copy of this waiver to any party affected by this provision.

**21.00 OSHA PROGRAM REQUIREMENTS:** The Contractor is familiar with the requirements of 292.675 RSMo. The Contractor shall provide a ten-hour Occupational Safety and Health Administration (OSHA) construction safety program for their on-site employees, subcontractors, or others acting on behalf of Contractor on-site which meets the requirements of 292.675 RSMo.

The Contractor and each subcontractor shall keep accurate records of those employees who are working on-site and a record of each such employee’s completion of the OSHA program, and certify compliance by affidavit at the conclusion of the project.

The Contractor shall forfeit as a penalty to the County the sum of Two Thousand Five Hundred Dollars (\$2,500.00) plus One Hundred Dollars (\$100.00) for each employee employed by the Contractor or

subcontractor, for each calendar day, or portion thereof, such employee is found to be employed in violation of 292.675 RSMo. Said amounts shall be withheld from all sums and amounts due under this provision when making payments to the Contractor.

**22.00 PAYMENT:** This will be a lump sum payment contract upon acceptance by Boone County. Contractor must submit an invoice and charges must only include prices listed in the vendor's bid response. No additional fees or taxes shall be included as additional charges. The County's purchase order must appear on the invoice. The County agrees to pay the invoice within thirty (30) days from receipt of a correct invoice and all other required documents.

**23.00 INVOICES:** Invoices should be submitted to Boone County Joint Communications, Attn: Pat Schreiner for payment 30 days after receipt of a correct and valid invoice. The billing address is Boone County Joint Communications, 17 N 7th Street, Suite A, Columbia, MO 65201.

**24.00 Bid Clarification:** Any questions or clarifications concerning bid documents should be addressed in writing, PRIOR TO BID OPENING, to Melinda Bobbitt, Director of Purchasing, 613 E. Ash Street, Room 110, Columbia, Missouri 65201. Phone: (573) 886-4391 Fax: (573) 886-4390 or Email: [mbobbitt@boonecountymo.org](mailto:mbobbitt@boonecountymo.org).

### 3. Response Presentation and Review

- 3.1. **RESPONSE CONTENT** – In order to enable direct comparison of competing Responses, Bidder must submit Response in strict conformity to the requirements stated herein. Failure to adhere to all requirements may result in Bidder's Response being disqualified as non-responsive. All Responses must be submitted using the provided Response Sheet. Every question must be answered and if not applicable, the section must contain "N/A". Manufacturer's published specifications for the items requested shall be included with the response.
- 3.2. **SUBMITTAL OF RESPONSES** – Responses **MUST** be received by the date and time notes on the title page under "Bid Submission Information and Deadline". **NO EXCEPTIONS**. The County is not responsible for late or incorrect deliveries from the US Postal Service or any other mail carrier.
- 3.3. **Advice of Award** – If you wish to be advised of the outcome of this Bid, the results may be viewed on the County's web page at [www.showmeboone.com](http://www.showmeboone.com).
- 3.4. **BID OPENING** – On the date and time and at the location specified on the title page, all Responses will be opened in public. Brief summary information from each will be read aloud, and any person present will be allowed, under supervision, to scan any Response. In the event only one bid is received by the date and time of the bid opening, County reserves the right to not open the bid and extend the Closing Date for the purpose of inviting bid responses from more vendors in the interest of establishing competition.
- 3.5. **Removal from Vendor Database** – If any prospective Bidder currently in our Vendor Database to whom the Bid was sent elects not to submit a Response and fails to reply in writing stating reason for not bidding, that Bidder's name may be removed from our database. Other reasons for removal include unwillingness or inability to show financial responsibility, reported poor performance, unsatisfactory service, or repeated inability to meet delivery requirements.
- 3.6. **RESPONSE CLARIFICATION** – The County reserves the right to request additional written or oral information from Bidders in order to obtain clarification of their Responses.
- 3.7. **Rejection or Correction of Responses** – The County reserves the right to reject any or all Responses. Minor irregularities or informalities in any Response which are immaterial or inconsequential in nature, and are neither affected by law nor at substantial variance with Bid conditions, may be waived at our discretion whenever it is determined to be in the County's best interest.
- 3.8. **EVALUATION PROCESS** – The County's sole purpose in the evaluation process is to determine from among the Responses received which one is best suited to meet the County's needs at the lowest possible cost. Any final analysis or weighted point score does not imply that one Bidder is superior to another, but simply that in our judgment the Contract selected appears to offer the best overall solution for our current and anticipated needs at the lowest possible cost.
- 3.9. **Method of Evaluation** – The County will evaluate submitted Responses in relation to all aspects of this Bid.
- 3.10. **Acceptability** – The County reserves the sole right to determine whether goods and/or services offered are acceptable for County use.
- 3.11. **Endurance of Pricing** – Bidder's pricing must be held until contract execution or 60 days, whichever comes first.

4. Response Form

Company Name: \_\_\_\_\_
Address: \_\_\_\_\_
City/Zip: \_\_\_\_\_
Phone Number: \_\_\_\_\_
E-Mail: \_\_\_\_\_
Fax Number: \_\_\_\_\_

Federal Tax I.D. \_\_\_\_\_
( ) Corporation
( ) Partnership - Name \_\_\_\_\_
( ) Individual/Proprietorship - Individual Name \_\_\_\_\_
( ) Other (Specify) \_\_\_\_\_

4.00 PRICING

4.01. Radio Tower Erection Service for Battle School project per the requirements stated herein.
\_\_\_\_\_ DOLLARS and \_\_\_\_\_ CENTS
(Quoted cost in print)
\$/\_\_\_\_\_ /LUMP SUM

4.02. Work will begin on project \_\_\_\_\_ days after receipt of Notice to Proceed.

4.03. Work will be completed \_\_\_\_\_ days after receipt of Notice to Proceed.

4.04. Subcontracting: If Vendor proposes to use subcontractors for this work, list the names of the firms and the work to be assigned in spaces below.

Table with 2 columns: Subcontractor Name/Address, Work Assigned. Includes two rows of blank lines for entry.

4.05. The undersigned offers to furnish and deliver the articles or services as specified at the prices and terms stated and in strict accordance with all requirements contained in the Request for Bid which have been read and understood, and all of which are made part of this order. By submission of this bid, the vendor certifies that they are in compliance with Section 34.353 and, if applicable, Section 34.359 (Missouri Domestic Products Procurement Act) of the Revised Statutes of Missouri.

Authorized Representative (Sign By Hand): \_\_\_\_\_ Date: \_\_\_\_\_

Print Name and Title of Authorized Representative: \_\_\_\_\_

## STATEMENT OF BIDDER'S QUALIFICATIONS

Each bidder for the work included in the specifications and plans and the Contract Documents shall submit with their bid the data requested in the following schedule of information. This data must be included in and made a part of each bid document and be contained in the sealed envelope. Failure to comply with this instruction may be regarded as justification for rejecting the Contractor's proposal.

1. Name of Bidder: \_\_\_\_\_
2. Business Address: \_\_\_\_\_
3. When Organized: \_\_\_\_\_
4. When Incorporated: \_\_\_\_\_
5. List federal tax identification number: \_\_\_\_\_  
If not incorporated, state type of business (sole proprietor, partnership, or other) \_\_\_\_\_
6. Number of years engaged in business under present firm name: \_\_\_\_\_
7. If you have done business under a different name, please give name and business location under that name: \_\_\_\_\_
8. Percent of work done by own staff: \_\_\_\_\_
9. Have you ever failed to complete any work awarded to your company? If so, where and why? \_\_\_\_\_
10. Have you ever defaulted on a contract? \_\_\_\_\_ If so, give \_\_\_\_\_
11. List of contracts completed within the last three years for work similar in scope to that described in this bid, including value of each. \_\_\_\_\_
12. List of projects currently in progress: \_\_\_\_\_

**\* Attach additional sheets as necessary \***

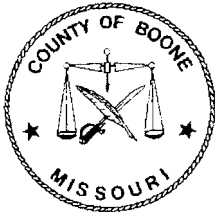

**Boone County Purchasing**  
613 E. Ash, Room 110  
Columbia, MO 65201

### ***Standard Terms and Conditions***

Melinda Bobbitt, CPPO, CPPB, Director of Purchasing  
Phone: (573) 886-4391 – Fax: (573) 886-4390

---

1. Contractor shall comply with all applicable federal, state, and local laws and failure to do so, in County's sole discretion, shall give County the right to terminate this Contract.
2. Responses shall include all charges for packing, delivery, installation, etc., (unless otherwise specified) to the Boone County Department identified in the Request for Bid and/or Proposal.
3. The Boone County Commission has the right to accept or reject any part or parts of all bids, to waive technicalities, and to accept the offer the County Commission considers the most advantageous to the County. Boone County reserves the right to award this bid on an item-by-item basis, or an "all or none" basis, whichever is in the best interest of the County.
4. Bidders must use the bid forms provided for the purpose of submitting bids, must return the bid and bid sheets comprised in this bid, give the unit price, extended totals, and sign the bid. The Purchasing Director reserves the right, when only one bid has been received by the bid closing date, to delay the opening of bids to another date and time in order to revise specifications and/or establish further competition for the commodity or service required. The one (1) bid received will be retained unopened until the new Closing date, or at request of bidder, returned unopened for re-submittal at the new date and time of bid closing.
5. When products or materials of any particular producer or manufacturer are mentioned in our specifications, such products or materials are intended to be descriptive of type or quality and not restricted to those mentioned.
6. Do not include Federal Excise Tax or Sales and Use Taxes in bid process, as law exempts the County from them.
7. The delivery date shall be stated in definite terms, as it will be taken into consideration in awarding the bid.
8. The County Commission reserves the right to cancel all or any part of orders if delivery is not made or work is not started as guaranteed. In case of delay, the Contractor must notify the Purchasing Department.
9. In case of default by the Contractor, the County of Boone will procure the articles or services from other sources and hold the Bidder responsible for any excess cost occasioned thereby.
10. Failure to deliver as guaranteed may disqualify Bidder from future bidding.
11. Prices must be as stated in units of quantity specified, and must be firm. Bids qualified by escalator clauses may not be considered unless specified in the bid specifications.

12. No bid transmitted by fax machine or e-mail will be accepted.
13. The County of Boone, Missouri expressly denies responsibility for, or ownership of any item purchased until same is delivered to the County and is accepted by the County.
14. The County reserves the right to award to one or multiple respondents. The County also reserves the right to not award any item or group of items if the services can be obtained from a state or other governmental entities contract under more favorable terms.
15. The County, from time to time, uses federal grant funds for the procurement of goods and services. Accordingly, the provider of goods and/or services shall comply with federal laws, rules and regulations applicable to the funds used by the County for said procurement, and contract clauses required by the federal government in such circumstances are incorporated herein by reference. These clauses can generally be found in the Federal Transit Administration's Best Practices Procurement Manual – Appendix A. Any questions regarding the applicability of federal clauses to a particular bid should be directed to the Purchasing Department prior to bid opening.
16. In the event of a discrepancy between a unit price and an extended line item price, the unit price shall govern.
17. Should an audit of Contractor's invoices during the term of the Agreement, and any renewals thereof, indicate that the County has remitted payment on invoices that constitute an over-charging to the County above the pricing terms agreed to herein, the Contractor shall issue a refund check to the County for any over-charges within 30-days of being notified of the same.
18. **For all titled vehicles and equipment the dealer must use the actual delivery date to the County on all transfer documents** including the Certificate of Origin (COO,) Manufacturer's Statement of Origin (MSO,) Bill of Sale (BOS,) and Application for Title.
19. **Equipment and serial and model numbers** - The contractor is strongly encouraged to include equipment serial and model numbers for all amounts invoiced to the County. If equipment serial and model numbers are not provided on the face of the invoice, such information may be required by the County before issuing payment.

## INSTRUCTIONS FOR COMPLIANCE WITH HOUSE BILL 1549

House Bill 1549 addresses the Department of Homeland Security's and the Social Security Administration's E-Verify Program (Employment Eligibility Verification Program) that requires the County to verify "lawful presence" of individuals when we contract for work/service; verify that contractor has programs to verify lawful presence of their employees when contracts exceed \$5,000; and a requirement for OSHA safety training for public works projects.

The County is required to obtain certification that the bidder awarded the attached contract participates in a federal work authorization program. To obtain additional information on the Department of Homeland Security's E-Verify program, go to:

<http://www.uscis.gov/portal/site/uscis/menuitem.eb1d4c2a3e5b9ac89243c6a7543f6d1a/?vgnextoid=75bce2e261405110VgnVCM1000004718190aRCRD&vgnextchannel=75bce2e261405110VgnVCM1000004718190aRCRD>

Please complete and return form *Work Authorization Certification Pursuant to 285.530 RSMo* if your contract amount is in excess of \$5,000. **Attach to this form the first and last page of the *E-Verify Memorandum of Understanding* that you completed when enrolling.**







**AFFIDAVIT**  
**(Only Required for Individual Bidder Certification Option #2)**

State of Missouri                    )  
  )SS.  
County of \_\_\_\_\_            )

I, the undersigned, being at least eighteen years of age, swear upon my oath that I am either a United States citizen or am classified by the United States government as being lawfully admitted for permanent residence.

\_\_\_\_\_  
Date

\_\_\_\_\_  
Signature

\_\_\_\_\_  
Social Security Number  
or Other Federal I.D. Number

\_\_\_\_\_  
Printed Name

On the date above written \_\_\_\_\_ appeared before me and swore that the facts contained in the foregoing affidavit are true according to his/her best knowledge, information and belief.

\_\_\_\_\_  
Notary Public

My Commission Expires:

**(Please complete and return with Bid)**

Certification Regarding  
Debarment, Suspension, Ineligibility and Voluntary Exclusion  
Lower Tier Covered Transactions

This certification is required by the regulations implementing Executive Order 12549, Debarment and Suspension, 29 CFR Part 98 Section 98.510, Participants' responsibilities. The regulations were published as Part VII of the May 26, 1988, Federal Register (pages 19160-19211).

(BEFORE COMPLETING CERTIFICATION, READ INSTRUCTIONS FOR CERTIFICATION)

- (1) The prospective recipient of Federal assistance funds certifies, by submission of this proposal, that neither it nor its principals are presently debarred, suspended, proposed for debarment, declared ineligible, or voluntarily excluded from participation in this transaction by any Federal department or agency.
- (2) Where the prospective recipient of Federal assistance funds is unable to certify to any of the statements in this certification, such prospective participant shall attach an explanation to this proposal.

---

Name and Title of Authorized Representative

---

Signature

---

Date

**ANTI-COLLUSION STATEMENT**

STATE OF MISSOURI

COUNTY OF \_\_\_\_\_

\_\_\_\_\_, being first duly sworn, deposes and

says that he is \_\_\_\_\_

(Title of Person Signing)

of \_\_\_\_\_

(Name of Bidder)

that all statements made and facts set out in the proposal for the above project are true and correct; and the bidder (person, firm, association, or corporation making said bid) has not, either directly or indirectly, entered into any agreement, participated in any collusion, or otherwise taken any action in restraint of free competitive bidding in connection with said bid or any contract which may result from its acceptance.

Affiant further certifies that bidder is not financially interested in, or financially affiliated with, any other bidder for the above project

By \_\_\_\_\_ By \_\_\_\_\_

By \_\_\_\_\_

Sworn to before me this \_\_\_\_\_ day of \_\_\_\_\_, 20 \_\_\_\_\_

\_\_\_\_\_  
Notary Public

My Commission Expires \_\_\_\_\_

**SIGNATURE AND IDENTITY OF BIDDER**

The undersigned states that the correct LEGAL NAME and ADDRESS of (1) the individual Bidder, (2) each partner or joint venture (whether individuals or corporations, and whether doing business under fictitious name), or (3) the corporation (with the state in which it is incorporated) are shown below; that (if not signing with the intention of binding himself to become the responsible and sole Contractor) he is the agent of, and duly authorized in writing to sign for the Bidder or Bidders; and that he is signing and executing this (as indicated in the proper spaces below) as the proposal of a:

- sole individual                       partnership                       joint venture  
 corporation, incorporated under laws of the state of \_\_\_\_\_

Dated \_\_\_\_\_, 20 \_\_\_\_\_

Name of individual, all partners, or joint venturers:

Address of each:

_____	_____
_____	_____
_____	_____
_____	_____

Address of principal place of business in doing business under the name of:

\_\_\_\_\_  
(If using a fictitious name, show this name above in addition to legal names.)

\_\_\_\_\_  
(If a corporation – show its name above)

ATTEST:

\_\_\_\_\_  
(Secretary)

\_\_\_\_\_  
(Title)

NOTE: If the Bidder is doing business under a FICTITIOUS NAME, the Proposal shall be executed in the legal name of the individual, partners, joint venturers, or corporation, with the legal address shown, and the REGISTRATION OF FICTITIOUS NAME filed with the Secretary of State, as required by Section 417.200 to 417.230, RS Mo. shall be attached. If the Bidder is a CORPORATION NOT ORGANIZED UNDER THE LAWS OF MISSOURI, it shall procure a CERTIFICATE OF AUTHORITY TO DO BUSINESS IN MISSOURI, as required by Section 351.570 and following, RS Mo. A CERTIFIED COPY of such Registration of Fictitious Name or Certificate of Authority to do Business in Missouri shall be filed with the Engineer.

**BIDDER'S ACKNOWLEDGMENT**

(Complete and fill out all parts applicable, and strike out all parts not applicable.)

State of \_\_\_\_\_ County of \_\_\_\_\_

On this \_\_\_\_\_ day of \_\_\_\_\_, 20 \_\_\_\_\_

before me appeared \_\_\_\_\_ to me personally known, who, being by me first duly sworn, did say that he executed the foregoing Proposal with full knowledge and understanding of all its terms and provisions and of the plans and specifications; that the correct legal name and address of the Bidder (including those of all partners of joint ventures if fully and correctly set out above; that all statements made therein by or for the Bidder are true; and (if a sole individual) acknowledged that he executed the same as his free act and deed.

(if a partnership or joint venture) acknowledged that his executed same, with written authority from, and as the free act and deed of, all said partners or joint ventures.

(if a corporation) that he is the \_\_\_\_\_  
President or other agent

of \_\_\_\_\_; that the above Proposal was signed and sealed in behalf of said corporation by authority of its board of directors; and he acknowledged said proposal to be the free act and deed of said corporation.

Witness my hand and seal at, \_\_\_\_\_ the day and year first above written. (SEAL).

\_\_\_\_\_  
Notary Public

My Commission expires \_\_\_\_\_, 20\_\_\_\_\_.

# Missouri Division of Labor Standards

WAGE AND HOUR SECTION

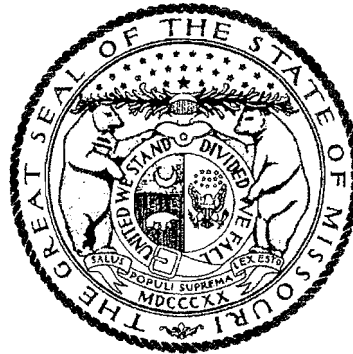

JEREMIAH W. (JAY) NIXON, Governor

## Annual Wage Order No. 22

Section 010  
BOONE COUNTY

In accordance with Section 290.262 RSMo 2000, within thirty (30) days after a certified copy of this Annual Wage Order has been filed with the Secretary of State as indicated below, any person who may be affected by this Annual Wage Order may object by filing an objection in triplicate with the Labor and Industrial Relations Commission, P.O. Box 599, Jefferson City, MO 65102-0599. Such objections must set forth in writing the specific grounds of objection. Each objection shall certify that a copy has been furnished to the Division of Labor Standards, P.O. Box 449, Jefferson City, MO 65102-0449 pursuant to 8 CSR 20-5.010(1). A certified copy of the Annual Wage Order has been filed with the Secretary of State of Missouri.

Original Signed by

John E. Lindsey, Director  
Division of Labor Standards

This Is A True And Accurate Copy Which Was Filed With The Secretary of State: March 10, 2015

Last Date Objections May Be Filed: April 9, 2015

Prepared by Missouri Department of Labor and Industrial Relations



OCCUPATIONAL TITLE	** Date of Increase	*	Basic Hourly Rates	Over-Time Schedule	Holiday Schedule	Total Fringe Benefits
Asbestos Worker (H & F) Insulator			\$32.06	55	60	\$20.71
Boilermaker	8/15		\$34.76	57	7	\$28.00
Bricklayer and Stone Mason	6/15		\$28.95	59	7	\$16.25
Carpenter	6/15		\$24.75	60	15	\$15.55
Cement Mason	6/15		\$26.83	9	3	\$11.95
Communication Technician	6/15		\$31.35	28	7	\$12.70 + 13%
Electrician (Inside Wireman)	6/15		\$31.35	28	7	\$12.70 + 13%
Electrician (Outside-Line Construction\Lineman)	9/15		\$42.52	43	45	\$5.00 + 36.5%
Lineman Operator	9/15		\$36.70	43	45	\$5.00 + 36.5%
Groundman	9/15		\$28.38	43	45	\$5.00 + 36.5%
Elevator Constructor		a	\$44.37	26	54	\$28.385
Glazier	10/15		\$26.57	122	76	\$11.33
Ironworker	8/15		\$28.41	11	8	\$24.04
Laborer (Building):						
General			\$21.71	42	44	\$12.84
First Semi-Skilled			\$23.71	42	44	\$12.84
Second Semi-Skilled			\$22.71	42	44	\$12.84
Lather			USE CARPENTER RATE			
Linoleum Layer and Cutter	6/15		\$24.63	60	15	\$15.55
Marble Mason	10/15		\$21.66	124	74	\$12.68
Marble Finisher	10/15		\$14.14	124	74	\$9.08
Millwright	6/15		\$25.75	60	15	\$15.55
Operating Engineer						
Group I	6/15		\$28.66	86	66	\$24.01
Group II	6/15		\$28.66	86	66	\$24.01
Group III	6/15		\$27.41	86	66	\$24.01
Group III-A	6/15		\$28.66	86	66	\$24.01
Group IV	6/15		\$26.43	86	66	\$24.01
Group V	6/15		\$29.36	86	66	\$24.01
Painter	6/15		\$22.94	18	7	\$11.33
Pile Driver	6/15		\$25.75	60	15	\$15.55
Pipe Fitter	7/15	b	\$37.00	91	69	\$26.68
Plasterer	6/15		\$25.40	94	5	\$12.00
Plumber	7/15	b	\$37.00	91	69	\$26.68
Roofer \ Waterproofer	10/15		\$29.30	12	4	\$14.87
Sheet Metal Worker	7/15		\$31.14	40	23	\$16.24
Sprinkler Fitter - Fire Protection	6/15		\$32.39	33	19	\$19.05
Terrazzo Worker			\$28.73	124	74	\$14.38
Terrazzo Finisher			\$18.68	124	74	\$14.38
Tile Setter	10/15		\$21.66	124	74	\$12.68
Tile Finisher	10/15		\$14.14	124	74	\$9.08
Traffic Control Service Driver			\$26.415	22	55	\$9.045
Truck Driver-Teamster						
Group I			\$25.30	101	5	\$10.70
Group II			\$25.95	101	5	\$10.70
Group III			\$25.45	101	5	\$10.70
Group IV			\$25.95	101	5	\$10.70

Fringe Benefit Percentage is of the Basic Hourly Rate

\*\*Annual Incremental Increase



**REPLACEMENT PAGE  
BOONE COUNTY  
BUILDING CONSTRUCTION OVERTIME SCHEDULE**

**FED:** Minimum requirement per Fair Labor Standards Act means time and one-half (1 ½) shall be paid for all work in excess of forty (40) hours per work week.

**NO. 9:** Means the regular workday starting time of 8:00 a.m. (and resulting quitting time of 4:30 p.m.) may be moved forward to 6:00 a.m. or delayed one hour to 9:00 a.m. All work performed in excess of the regular work day and on Saturday shall be compensated at one and one-half (1½) times the regular pay. In the event time is lost during the work week due to weather conditions, the Employer may schedule work on the following Saturday at straight time. All work accomplished on Sunday and holidays shall be compensated for at double the regular rate of wages. The work week shall be Monday through Friday, except for midweek holidays.

**NO. 11:** Means eight (8) hours shall constitute a day's work, with the starting time to be established between 6:00 a.m. and 8:00 a.m. from Monday to Friday. Time and one-half (1½) shall be paid for first two (2) hours of overtime Monday through Friday and the first eight (8) hours on Saturday. All other overtime hours Monday through Saturday shall be paid at double (2) time rate. Double (2) time shall be paid for all time on Sunday and recognized holidays or the days observed in lieu of these holidays.

**NO. 12:** Means the work week shall commence on Monday at 12:01 a.m. and shall continue through the following Friday, inclusive of each week. All work performed by employees anywhere in excess of forty (40) hours in one (1) work week, shall be paid for at the rate of one and one-half (1½) times the regular hourly wage scale. All work performed within the regular working hours which shall consist of a ten (10) hour work day except in emergency situations. Overtime work and Saturday work shall be paid at one and one-half (1½) times the regular hourly rate. Work on recognized holidays and Sundays shall be paid at two (2) times the regular hourly rate.

**NO. 18:** Means the regular work day shall be eight (8) hours. Working hours are from six (6) hours before Noon (12:00) to six (6) hours after Noon (12:00). The regular work week shall be forty (40) hours, beginning between 6:00 a.m. and 12:00 Noon on Monday and ending between 1:00 p.m. and 6:00 p.m. on Friday. Saturday will be paid at time and one-half (1½). Sunday and Holidays shall be paid at double (2) time. Saturday can be a make-up day if the weather has forced a day off, but only in the week of the day being lost. Any time before six (6) hours before Noon or six (6) hours after Noon will be paid at time and one-half (1½).

**NO. 22:** Means a regular work week of forty (40) hours will start on Monday and end on Friday. The regular work day shall be either eight (8) or ten (10) hours. If a crew is prevented from working forty (40) hours Monday through Friday, or any part thereof by reason of inclement weather, Saturday or any part thereof may be worked as a make-up day at the straight time rate. Employees who are part of a regular crew on a make-up day, notwithstanding the fact that they may not have been employed the entire week, shall work Saturday at the straight time rate. A workday is to begin between 6:00 a.m. and 9:00 a.m. However, the project starting time may be advanced or delayed if mutually agreed to by the interest parties. For all time worked on recognized holidays, or days observed as such, double (2) time shall be paid.

**NO. 26:** Means that the regular working day shall consist of eight (8) hours worked between 6:00 a.m., and 5:00 p.m., five (5) days per week, Monday to Friday, inclusive. Hours of work at each jobsite shall be those established by the general contractor and worked by the majority of trades. (The above working hours may be changed by mutual agreement). Work performed on Construction Work on Saturdays, Sundays and before and after the regular working day on Monday to Friday, inclusive, shall be classified as overtime, and paid for at double (2) the rate of single time. The employer may establish hours worked on a jobsite for a four (4) ten (10) hour day work week at straight time pay for construction work; the regular working day shall consist of ten (10) hours worked consecutively, between 6:00 a.m. and 6:00 p.m., four (4) days per week, Monday to Thursday, inclusive. Any work performed on Friday, Saturday, Sunday and holidays, and before and after the regular working day on Monday to Thursday where a four (4) ten (10) hour day workweek has been established, will be paid at two times (2) the single time rate of pay. The rate of pay for all work performed on holidays shall be at two times (2) the single time rate of pay.

**REPLACEMENT PAGE  
BOONE COUNTY  
BUILDING CONSTRUCTION OVERTIME SCHEDULE**

**NO. 28:** Means a regular workday shall consist of eight (8) hours between 7:00 a.m. and 5:30 p.m., with at least a thirty (30) minute period to be taken for lunch. Five (5) days a week, Monday through Friday inclusive, shall constitute a work week. The Employer has the option for a workday/workweek of four (4) ten (10) hour days (4-10's) provided:

- The project must be for a minimum of four (4) consecutive days.
- Starting time may be within one (1) hour either side of 8:00 a.m.
- Work week must begin on either a Monday or Tuesday: If a holiday falls within that week it shall be a consecutive work day. (Alternate: If a holiday falls in the middle of a week, then the regular eight (8) hour schedule may be implemented).
- Any time worked in excess of any ten (10) hour work day (in a 4-10 hour work week) shall be at the appropriate overtime rate.

All work outside of the regular working hours as provided, Monday through Saturday, shall be paid at one & one-half (1½) times the employee's regular rate of pay. All work performed from 12:00 a.m. Sunday through 8:00 a.m. Monday and recognized holidays shall be paid at double (2) the straight time hourly rate of pay. Should employees work in excess of twelve (12) consecutive hours they shall be paid double time (2X) for all time after twelve (12) hours. Shift work performed between the hours of 4:30 p.m. and 12:30 a.m. (second shift) shall receive eight (8) hours pay at the regular hourly rate of pay plus ten (10%) percent for seven and one-half (7½) hours work. Shift work performed between the hours of 12:30 a.m. and 8:00 a.m. (third shift) shall receive eight (8) hours pay at the regular hourly rate of pay plus fifteen (15%) percent for seven (7) hours work. A lunch period of thirty (30) minutes shall be allowed on each shift. All overtime work required after the completion of a regular shift shall be paid at one and one-half (1½) times the shift hourly rate.

**NO. 33:** Means the standard work day and week shall be eight (8) consecutive hours of work between the hours of 6:00 a.m. and 6:00 p.m., excluding the lunch period Monday through Friday, or shall conform to the practice on the job site. Four (4) days at ten (10) hours a day may be worked at straight time, Monday through Friday and need not be consecutive. All overtime, except for Sundays and holidays shall be at the rate of time and one-half (1½). Overtime worked on Sundays and holidays shall be at double (2) time.

**NO. 40:** Means the regular working week shall consist of five (5) consecutive (8) hour days' labor on the job beginning with Monday and ending with Friday of each week. Four (4) 10-hour days may constitute the regular work week. The regular working day shall consist of eight (8) hours labor on the job beginning as early as 6:00 a.m. and ending as late as 5:30 p.m. All full or part time labor performed during such hours shall be recognized as regular working hours and paid for at the regular hourly rate. All hours worked on Saturday and all hours worked in excess of eight (8) hours but not more than twelve (12) hours during the regular working week shall be paid for at time and one-half (1½) the regular hourly rate. All hours worked on Sundays and holidays and all hours worked in excess of twelve (12) hours during the regular working day shall be paid at two (2) times the regular hourly rate. In the event of rain, snow, cold or excessively windy weather on a regular working day, Saturday may be designated as a "make-up" day. Saturday may also be designated as a "make-up" day, for an employee who has missed a day of work for personal or other reasons. Pay for "make-up" days shall be at regular rates.

**REPLACEMENT PAGE  
BOONE COUNTY  
BUILDING CONSTRUCTION OVERTIME SCHEDULE**

**NO. 42:** Means eight (8) hours between the hours of 8:00 a.m. and 4:30 p.m. shall constitute a work day. The starting time may be advanced one (1) or two (2) hours. Employees shall have a lunch period of thirty (30) minutes. The Employer may provide a lunch period of one (1) hour, and in that event, the workday shall commence at 8:00 a.m. and end at 5:00 p.m. The workweek shall commence at 8:00 a.m. on Monday and shall end at 4:30 p.m. on Friday (or 5:00 p.m. on Friday if the Employer grants a lunch period of one (1) hour), or as adjusted by starting time change as stated above. All work performed before 8:00 a.m. and after 4:30 p.m. (or 5:00 p.m. where one (1) hour lunch is granted for lunch) or as adjusted by starting time change as stated above or on Saturday, except as herein provided, shall be compensated at one and one-half (1½) times the regular hourly rate of pay for the work performed. All work performed on Sunday and on recognized holidays shall be compensated at double (2) the regular hourly rate of pay for the work performed. When working a five 8-hour day schedule and an Employer is prevented from working forty (40) hours, Monday through Friday, or any part thereof by reason of inclement weather (rain or mud), Saturday or any part thereof may be worked as a make-up day at the straight time rate. The Employer shall have the option of working five eight (8) hour days or four ten (10) hour days Monday through Friday. If an Employer elects to work five (5) eight (8) hour days during any work week, hours worked more than eight (8) per day or forty (40) hours per week shall be paid at time and one-half (1½) the hourly rate Monday through Friday. If an Employer elects to work four (4) ten (10) hour days in any week, work performed more than ten (10) hours per day or forty (40) hours per week shall be paid at time and one-half (1½) the hourly rate Monday through Friday. If an Employer is working ten (10) hour days and loses a day due to inclement weather, they may work ten (10) hours Friday at straight time. All hours worked over the forty (40) hours Monday through Friday will be paid at time and one-half (1½) overtime rate. Overtime shall be computed at half-hour intervals. Shift Work: Two (2) or three (3) shifts shall be permitted, provided such shifts are scheduled for a minimum of three (3) consecutive days. The second shift shall begin at 4:30 p.m. and end at 12:30 a.m. with one-half (1/2) hour for lunch between 7:30 p.m. and 9:00 p.m. and shall received eighty (8) hours' pay. The third shift shall begin at 12:30 a.m. and end at 8:00 a.m. with one-half (1/2) hour for lunch between 3:30 a.m. and 5:00 a.m. and shall received (8) hour's: pay. There shall be at least one (1) foreman on each shift on jobs where more than one shift is employed, provided that there are two (2) or more employees on second and on the third shifts. All shifts shall arrange to interchange working hours at the end of each week. When three shifts are used, the applicable rate must be paid from Saturday at 8:00 a.m. until the following Monday at 8:00 a.m. When three shifts are employed, the second and third shifts shall contain at least one-half (1/2) as many employees as the first shift.

**NO. 43:** Eight (8) hours shall constitute a work day between the hours of 7:00 a.m. and 4:30 p.m. Forty (40) hours within five (5) days, Monday through Friday inclusive, shall constitute the work week. Work performed in the 9th and 10th hour, Monday through Friday, shall be paid at time and one-half (1½) the regular straight time rate of pay. Contractor has the option to pay two (2) hours per day at the time and one-half (1½) the regular straight time rate of pay between the hours of 6:00 a.m. and 5:30 p.m., Monday through Friday. Work performed outside the regularly scheduled working hours and on Saturdays, Sundays and recognized legal holidays, or days celebrated as such, shall be paid for at the rate of double (2) time.

**NO. 55:** Means the regular work day shall be eight (8) hours between 6:00 a.m. and 4:30 p.m. The first two (2) hours of work performed in excess of the eight (8) hour work day, Monday through Friday, and the first ten (10) hours of work on Saturday, shall be paid at one & one-half (1½) times the straight time rate. All work performed on Sunday, observed holidays and in excess of ten (10) hours a day, Monday through Saturday, shall be paid at double (2) the straight time rate.

**NO. 57:** Means eight (8) hours per day shall constitute a day's work and forty (40) hours per week, Monday through Friday, shall constitute a week's work. The regular starting time shall be 8:00 a.m. If a second or third shift is used, the regular starting time of the second shift shall be 4:30 p.m. and the regular starting period for the third shift shall be 12:30 a.m. These times may be adjusted by the employer. The day shift shall work a regular eight (8) hours shift as outlined above. Employees working a second shift shall receive an additional \$0.25 above the regular hourly rate and perform seven and one-half (7½) hours work for eight (8) hours pay. Third shift employees shall be paid an additional \$0.50 above the regular hourly rate and work seven (7) hours for eight (8) hours pay. When circumstances warrant, the Employer may change the regular workweek to four (4) ten-hour days at the regular time rate of pay. All time worked before and after the established workday of eight (8) hours, Monday through Friday, and all time worked on Saturday shall be paid at the rate of time and one-half (1½) except in cases where work is part of an employee's regular Friday shift. All time worked on Sunday and recognized holidays shall be paid at the double (2) time rate of pay except in cases where work is part of an employee's previous day's shift. For all overtime hours worked \$26.71 of the fringe benefits portion of the prevailing wage shall be paid at the same overtime rate at which the cash portion of the prevailing wage is to be paid. The remaining \$1.29 of the fringe benefit portion of the prevailing wage may be paid at straight time.

**REPLACEMENT PAGE  
BOONE COUNTY  
BUILDING CONSTRUCTION OVERTIME SCHEDULE**

**NO. 59:** Means that except as herein provided, eight (8) hours a day shall constitute a standard work day, and forty (40) hours per week shall constitute a week's work. All time worked outside of the standard eight (8) hour work day and on Saturday shall be classified as overtime and paid the rate of time and one-half (1½). All time worked on Sunday and holidays shall be classified as overtime and paid at the rate of double (2) time. The Employer has the option of working either five (5) eight hour days or four (4) ten hour days to constitute a normal forty (40) hour work week. When the four (4) ten-hour work week is in effect, the standard work day shall be consecutive ten (10) hour periods between the hours of 6:30 a.m. and 6:30 p.m. Forty (40) hours per week shall constitute a week's work, Monday through Thursday, inclusive. In the event the job is down for any reason beyond the Employer's control, then Friday and/or Saturday may, at the option of the Employer, be worked as a make-up day; straight time not to exceed ten (10) hours or forty (40) hours per week. When the five day eight (8) hour work week is in effect, forty (40) hours per week shall constitute a week's work, Monday through Friday, inclusive. In the event the job is down for any reason beyond the Employer's control, then Saturday may, at the option of the Employer, be worked as a make-up day; straight time not to exceed eight (8) hours or forty (40) hours per week. The regular starting time (and resulting quitting time) may be moved to 6:00 a.m. or delayed to 9:00 a.m. Make-up days shall not be utilized for days lost due to holidays.

**NO. 60:** Means the Employer shall have the option of working five 8-hour days or four 10-hour days Monday through Friday. If an Employer elects to work five 8-hour days during any work week, hours worked more than eight (8) per day or forty (40) per week shall be paid at time and one-half (1½) the hourly wage rate plus fringe benefits Monday through Friday. **SATURDAY MAKE-UP DAY:** If an Employer is prevented from working forty (40) hours, Monday through Friday, or any part thereof by reason of inclement weather (rain or mud), Saturday or any part thereof may be worked as a make-up day at the straight time rate. It is agreed by the parties that the make-up day is not to be used to make up time lost due to recognized holidays. If an Employer elects to work four 10-hour days, between the hours of 6:30 a.m. and 6:30 p.m. in any week, work performed more than ten (10) hours per day or forty (40) hours per week shall be paid at time and one half (1½) the hourly wage rate plus fringe benefits Monday through Friday. If an Employer is working 10-hour days and loses a day due to inclement weather, the Employer may work ten (10) hours on Friday at straight time. All hours worked over the forty (40) hours Monday through Friday will be paid at time and one-half (1½) the hourly wage rate plus fringe benefits. All Millwright work performed in excess of the regular work day and on Saturday shall be compensated for at time and one-half (1½) the regular Millwright hourly wage rate plus fringe benefits. The regular work day starting at 8:00 a.m. (and resulting quitting time of 4:30 p.m.) may be moved forward to 6:00 a.m. or delayed one (1) hour to 9:00 a.m. All work accomplished on Sundays and recognized holidays, or days observed as recognized holidays, shall be compensated for at double (2) the regular hourly rate of wages plus fringe benefits. **NOTE:** All overtime is computed on the hourly wage rate plus an amount equal to the fringe benefits.

**NO. 86:** The regular workday shall consist of eight (8) consecutive hours, exclusive of a thirty (30) minute lunch period, with pay at the straight time rate with all hours in excess of eight (8) hours in any one day to be paid at the applicable overtime rate at time and one-half (1½). The regular workday shall begin between the hours of 6:00 a.m. and 8:00 a.m. The Employer may have the option to schedule the work week from Monday through Thursday at ten (10) hours per day at the straight time rate of pay with all hours in excess of ten (10) hours in any one day to be paid at the applicable overtime rate at time and one-half (1½). If the Employer elects to work from Monday through Thursday and is stopped due to inclement weather, holiday or other conditions beyond the control of the Employer, they shall have the option to work Friday at the straight time rate of pay to complete the forty (40) hours for the workweek. All overtime work performed on Monday through Saturday shall be paid at time and one-half (1½) the hourly rate. Fringe benefits shall be paid at the one and one half the hourly rate. All work performed on Sundays and recognized holidays shall be paid at double (2) the hourly rate. Fringe benefits shall be paid at double the hourly rate. Shifts may be established when considered necessary by the Employer. Shift hours and rates will be as follows. If shifts are established, work on the First Shift will begin between 6:00 a.m. and 9:00 a.m. and consist of eight (8) hours of work plus one-half hour unpaid lunch. Hours worked during the first shift will be paid at the straight time rate of pay. The second shift shall start eight hours after the start of the first shift and consist of eight (8) hours of work plus one-half hour unpaid lunch. Work on the second shift will begin between 2:00 p.m. and 5:00 p.m. and be paid the straight time rate plus \$2.50 per hour. The third shift shall start eight hours after the start of the second shift and consist of eight (8) hours plus one-half hour unpaid lunch. Work on the third shift will begin between 10:00 p.m. and 1:00 a.m. and be paid the straight time rate plus \$3.50 per hour. The additional amounts that are to be paid are only applicable when working shifts. Shifts that begin on Saturday morning through those shifts which end on Sunday morning will be paid at time and one-half these rates. Shifts that begin on Sunday morning through those shifts which end on Monday morning will be paid at double time these rates.

**REPLACEMENT PAGE  
BOONE COUNTY  
BUILDING CONSTRUCTION OVERTIME SCHEDULE**

**NO. 87:** Means eight (8) hours starting between 6:00 a.m. and 8:00 a.m. and ending between 2:30 p.m. and 4:30 p.m. at the Employers discretion shall constitute a day's work. Any work prior to 6:00 a.m. or after eight (8) hours shall be paid at the overtime rate. Five (5) days from Monday through Friday inclusive shall constitute a regular work week. All hours before and after these regular hours shall be considered overtime and shall be paid for at the rate of double (2) time. All work on Saturday and Sunday shall be paid at double (2) the prevailing scale of wages.

**NO. 91:** Means eight (8) hours shall constitute a day's work commencing at 7:00 a.m. and ending at 3:30 p.m., allowing one-half (½) hour for lunch. The option exists for the Employer to use a flexible starting time between the hours of 6:00 a.m. and 9:00 a.m. The regular workweek shall consist of forty (40) hours of five (5) workdays, Monday through Friday. The workweek may consist of four (4) ten (10) hour days from Monday through Thursday, with Friday as a make-up day. If the make-up day is a holiday, the employee shall be paid at the double (2) time rate. The employees shall be paid time and one-half (1½) for work performed on Saturdays, before the regular starting time or after the regular quitting time or over eight (8) hours per work day (unless working a 10-hour work day, then time and one-half (1½) is paid for work performed over ten (10) hours a day) or over forty (40) hours per work week. Work performed on Sundays and recognized holidays shall be paid at the double (2) time rate of pay. **SHIFT WORK:** When it is necessary for the project to operate in shifts, there will be three (3) eight (8) hour shifts commencing at 8:00 a.m. Shift work must continue for a period of not less than three (3) consecutive work days, two (2) days which must be regular work days (Monday through Friday). In the event the second or third shift of any regular work day shall fall into a Saturday or a holiday, such extension into a Saturday or holiday shall be considered as part of the previous workday and employees shall be paid at the regular shift rate. The first day shift shall work a regular eight (8) hour day at regular rates. The second shift shall be eight (8) hours regular time pay plus \$2.50 per hour premium for eight (8) hours work. Third shift will be for eight (8) hours regular time pay plus \$3.00 per hour premium for eight (8) hours work.

**NO. 94:** Means eight (8) hours shall constitute a day's work between the hours of 8:00 a.m. and 5:00 p.m. The regular workday starting time of 8:00 a.m. (and resulting quitting time of 4:30 p.m.) may be moved forward to 6:00 a.m. or delayed one (1) hour to 9:00 a.m. All work performed in excess of the regular work day and on Saturday shall be compensated at one and one-half (1½) times the regular pay. In the event time is lost during the work week due to weather conditions, the Employer may schedule work on the following Saturday at straight time. All work accomplished on Sunday and holidays shall be compensated at double the regular rate of wages.

**NO. 101:** Means that except as provided below, eight (8) hours a day shall constitute a standard work day, and forty (40) hours per week shall constitute a week's work, which shall begin on Monday and end on Friday. All time worked outside of the standard work day and on Saturday shall be classified as overtime and paid the rate of time and one-half (1½) (except as herein provided). All time worked on Sunday and recognized holidays shall be classified as overtime and paid at the rate of double (2) time. The regular starting time of 8:00 a.m. (and resulting quitting time of 4:30 p.m.) may be moved forward to 6:00 a.m. or delayed one (1) hour to 9:00 a.m. The Employer has the option of working either five (5) eight-hour days or four (4) ten-hour days to constitute a normal forty (40) hour work week. When a four (4) ten-hour day work week is in effect, the standard work day shall be consecutive ten (10) hour periods between the hours of 6:30 a.m. and 6:30 p.m. Forty (40) hours per week shall constitute a week's work Monday through Thursday, inclusive. In the event the job is down for any reason beyond the Employer's control, then Friday and/or Saturday may, at the option of the Employer, be worked as a make-up day; straight time not to exceed ten (10) hours per day or forty (40) hours per week. Starting time will be designated by the employer. When the five (5) day eight (8) hour work week is in effect, forty (40) hours per week shall constitute a week's work, Monday through Friday, inclusive. In the event the job is down for any reason beyond the Employer's control, then Saturday may, at the option of the Employer, be worked as a make-up day; straight time not to exceed eight (8) hours per day or forty (40) hours per week. Make-up days shall not be utilized for days lost due to holidays.

**NO. 122:** Means forty (40) hours between Monday and Friday shall constitute the normal work week. Work shall be scheduled between the hours of 6:00 a.m. and 6:30 p.m., with one-half hour for lunch. Work in excess of eight (8) hours per day and forty (40) hours per week, and on Saturdays, shall be paid at the rate of one and one-half times the normal rate. Due to inclement weather during the week, Saturday shall be a voluntary make up day.

**REPLACEMENT PAGE  
BOONE COUNTY  
BUILDING CONSTRUCTION OVERTIME SCHEDULE**

**NO. 124:** Means eight (8) hours shall constitute a day's work on all classes of work between the hours of 6:00 a.m. and 5:30 p.m., Monday through Friday. The pay for time worked during these hours shall be at the regular wage rate. The regular workweek shall be Monday through Friday. Employment from 4:30 p.m. to 12:00 midnight, Monday through Friday, shall be paid for at one and one-half (1½) times the regular hourly rate. From 12:00 midnight until 8:00 a.m. on any day shall be paid for at twice the regular hourly rate. All time worked on Sundays and the recognized holidays shall be paid at the rate of double (2) time. It is understood that forty (40) hours shall constitute a regular workweek, (5-8's) Sunday Midnight through Friday Midnight, understanding anything over eight (8) hours is one and one-half (1½) times the hourly wage rate.



## BOONE COUNTY HOLIDAY SCHEDULE – BUILDING CONSTRUCTION

**NO. 3:** All work done on New Year's Day, Decoration Day, July 4th, Labor Day, Veteran's Day, Thanksgiving and Christmas shall be compensated at the double (2) time rate of pay. When any of these holidays fall on a Sunday, the following Monday shall be observed.

**NO. 4:** All work done on New Year's Day, Memorial Day, Independence Day, Labor Day, Thanksgiving and Christmas Day shall be paid at the double time rate of pay. If any of the above holidays fall on Sunday, Monday will be observed as the recognized holiday. If any of the above holidays fall on Saturday, Friday will be observed as the recognized holiday.

**NO. 5:** All work that shall be done on New Year's Day, Memorial Day, Fourth of July, Labor Day, Veteran's Day, Thanksgiving Day, and Christmas Day shall be paid at the double (2) time rate of pay.

**NO. 7:** The following days are assigned days and are recognized as holidays: New Year's Day, Memorial Day, Independence Day, Labor Day, Veteran's Day, Thanksgiving Day, and Christmas Day. If a holiday falls on a Sunday, it shall be observed on the following Monday. If a holiday falls on a Saturday, it shall be observed on the preceding Friday. No work shall be performed on Labor Day except in case of jeopardy to work under construction. This is applied to protect Labor Day. When a holiday falls during the normal workweek, Monday through Friday, it shall be counted as eight (8) hours toward the forty (40) hour week. However, no reimbursement for these eight (8) hours is to be paid to the workman unless worked. If workman are required to work the above enumerated holidays or days observed as such, or on Sunday, they shall receive double (2) the regular rate of pay for such work.

**NO. 8:** All work performed on New Year's Day, Memorial Day, Independence Day, Labor Day, Veteran's Day, Thanksgiving Day, and Christmas Day, or the days observed in lieu of these holidays, shall be paid at the double time rate of pay.

**NO. 15:** All work accomplished on the recognized holidays of New Year's Day, Decoration Day (Memorial Day), Independence Day (Fourth of July), Labor Day, Veteran's Day, Thanksgiving Day and Christmas Day, or days observed as these named holidays, shall be compensated for at double (2) the regular hourly rate of wages plus fringe benefits. If a holiday falls on Saturday, it shall be observed on the preceding Friday. If a holiday falls on a Sunday, it shall be observed on the following Monday. No work shall be performed on Labor Day, Christmas Day, Decoration Day or Independence Day except to preserve life or property.

**NO. 19:** All work done on New Year's Day, Memorial Day, July 4th, Labor Day, Thanksgiving Day, and Christmas Day shall be paid at the double time rate of pay. The employee may take off Friday following Thanksgiving Day. However, the employee shall notify his or her Foreman, General Foreman or Superintendent on the Wednesday preceding Thanksgiving Day. When one of the above holidays falls on Sunday, the following Monday shall be considered a holiday and all work performed on either day shall be at the double (2) time rate. When one of the holidays falls on Saturday, the preceding Friday shall be considered a holiday and all work performed on either day shall be at the double (2) time rate.

**NO. 23:** All work done on New Year's Day, Memorial Day, Independence Day, Labor Day, Veteran's Day, Thanksgiving Day, Christmas Day and Sundays shall be recognized holidays and shall be paid at the double time rate of pay. When a holiday falls on Sunday, the following Monday shall be considered a holiday. When a holiday falls on Saturday, Friday is recognized as a holiday.

**NO. 31:** All work done on New Year's Day, Presidents Day, Good Friday, Memorial Day, Fourth of July, Labor Day, Veteran's Day, Thanksgiving Day, Friday after Thanksgiving Day, Christmas Day, and Employee's Birthday shall be paid at the double time rate of pay. If a holiday falls on Sunday, the following Monday will be observed as the recognized holiday. If a holiday falls on Saturday, the preceding Friday will be observed as the recognized holiday.

## **BOONE COUNTY HOLIDAY SCHEDULE – BUILDING CONSTRUCTION**

**NO. 44:** All work done on New Year's Day, Memorial Day, Independence Day, Veteran's Day, Thanksgiving Day, and Christmas Day shall be paid at the double time rate of pay. If a holiday falls on a Sunday, it shall be observed on the Monday following. If a holiday falls on a Saturday, it shall be observed on the preceding Friday. No work shall be performed on these days except in emergency to protect life or property. All work performed on these holidays shall be compensated at double the regular hourly rate for the work performed. Overtime shall be computed at half-hour intervals.

**NO. 45:** All work performed on New Year's Day, Memorial Day, Independence Day, Labor Day, Veteran's Day, Thanksgiving Day, the day after Thanksgiving, the day before Christmas, and Christmas Day, shall be paid at the double time rate of pay.

**NO. 54:** All work performed on New Year's Day, Memorial Day, Independence Day, Labor Day, Veteran's Day, Thanksgiving Day, the Friday after Thanksgiving Day, and Christmas Day shall be paid at the double (2) time rate of pay. When a holiday falls on Saturday, it shall be observed on Friday. When a holiday falls on Sunday, it shall be observed on Monday.

**NO. 55:** The following days are recognized as holidays: New Year's Day, Memorial Day, Independence Day, Labor Day, Thanksgiving Day and Christmas Day. If a holiday falls on a Sunday, it shall be observed on the following Monday. No work shall be performed on Labor Day except in case of jeopardy to work under construction. This rule is applied to protect Labor Day. When a holiday falls during the normal work week, Monday through Friday, it shall be counted as eight (8) hours toward the forty (40) hour week; however, no reimbursement for this eight (8) hours is to be paid the workmen unless worked. An Employer working a four (4) day, ten (10) hour schedule may use Friday as a make up day when an observed holiday occurs during the work week. Employees have the option to work that make up day. If workmen are required to work the above enumerated holidays, or days observed as such, they shall receive double (2) the regular rate of pay for such work.

**NO. 60:** All work performed on New Year's Day, Armistice Day (Veteran's Day), Decoration Day (Memorial Day), Independence Day (Fourth of July), Thanksgiving Day and Christmas Day shall be paid at the double time rate of pay. No work shall be performed on Labor Day except when triple (3) time is paid. When a holiday falls on Saturday, Friday will be observed as the holiday. When a holiday falls on Sunday, the following Monday shall be observed as the holiday.

**NO. 66:** All work performed on Sundays and the following recognized holidays, or the days observed as such, of New Year's Day, Decoration Day, Fourth of July, Labor Day, Veteran's Day, Thanksgiving Day and Christmas Day, shall be paid at double (2) the hourly rate plus an amount equal to the hourly Total Indicated Fringe Benefits. Whenever any such holidays fall on a Sunday, the following Monday shall be observed as a holiday.

**NO. 69:** All work performed on New Year's Day, Memorial Day, July Fourth, Labor Day, Veteran's Day, Thanksgiving Day or Christmas Day shall be compensated at double (2) their straight-time hourly rate of pay. Friday after Thanksgiving and the day before Christmas are also holidays, however, if the employer chooses to work the normal work hours on these days, the employee will be paid at straight -time rate of pay. If a holiday falls on a Saturday, the holiday will be observed on Saturday; if a holiday falls on a Sunday, the holiday will be observed on the following Monday.

**NO. 74:** All work performed on New Year's Day, Memorial Day, Fourth of July, Labor Day, Veteran's Day, Thanksgiving Day and Christmas Day, shall be paid at double (2) time of the hourly rate of pay. In the event one of the above holiday's falls on Saturday, the holiday shall be celebrated on Saturday. If the holiday falls on Sunday, the holiday will be celebrated on Monday.

**NO. 76:** Work performed on Holidays shall be paid at the rate of two times the normal rate. Holidays are: New Years Day, Memorial Day, Independence Day, Labor Day, Thanksgiving Day, Day after Thanksgiving, Christmas Day. If a holiday falls on a Sunday, it shall be celebrated on the following Monday, if it falls on Saturday, it shall be celebrated on the preceding Friday.

OCCUPATIONAL TITLE	* Date of Increase	Basic Hourly Rates	Over-Time Schedule	Holiday Schedule	Total Fringe Benefits
Carpenter	6/15	\$30.41	23	16	\$15.55
Electrician (Outside-Line Construction)\Lineman)	9/15	\$42.52	9	12	\$5.00 + 36.5%
Lineman Operator	9/15	\$36.70	9	12	\$5.00 + 36.5%
Lineman - Tree Trimmer	10/15	\$23.90	32	31	\$9.73 + 3%
Groundman	9/15	\$28.38	9	12	\$5.00 + 36.5%
Groundman - Tree Trimmer	10/15	\$17.64	32	31	\$7.72 + 3%
Laborer					
General Laborer	6/15	\$27.36	2	4	\$12.82
Skilled Laborer	6/15	\$27.36	2	4	\$12.82
Millwright	6/15	\$30.41	23	16	\$15.55
Operating Engineer					
Group I	6/15	\$27.74	21	5	\$23.91
Group II	6/15	\$27.39	21	5	\$23.91
Group III	6/15	\$27.19	21	5	\$23.91
Group IV	6/15	\$23.54	21	5	\$23.91
Oiler-Driver	6/15	\$23.54	21	5	\$23.91
Pile Driver	6/15	\$30.41	23	16	\$15.55
Traffic Control Service Driver		\$26.415	28	27	\$9.045
Truck Driver-Teamster					
Group I	6/15	\$28.87	25	21	\$12.05
Group II	6/15	\$29.03	25	21	\$12.05
Group III	6/15	\$29.02	25	21	\$12.05
Group IV	6/15	\$29.14	25	21	\$12.05

Use Heavy Construction Rates on Highway and Heavy construction in accordance with the classifications of construction work established in 8 CSR 30-3.040(3).

Use Building Construction Rates on Building construction in accordance with the classifications of construction work established in 8 CSR 30-3.040(2).

If a worker is performing work on a heavy construction project within an occupational title that is not listed on the Heavy Construction Rate Sheet, use the rate for that occupational title as shown on the Building Construction Rate sheet.

**REPLACEMENT PAGE  
BOONE COUNTY  
OVERTIME SCHEDULE - HEAVY CONSTRUCTION**

**FED:** Minimum requirement per Fair Labor Standards Act means time and one-half (1 ½) shall be paid for all work in excess of forty (40) hours per work week.

**NO. 2:** Means a regular workweek shall be forty (40) hours and will start on Monday and end on Friday. The Employer shall have the option of working five 8-hour days or four 10-hour days Monday through Friday. If an Employer elects to work five 8-hour days during any workweek, hours worked more than eight (8) per day or 40 per week shall be paid at time and one-half the hourly rate Monday through Friday. If an Employer elects to work four 10-hour days in a week, work performed more than ten (10) hours per day or 40 hours per week shall be paid at time and one-half the hourly rate Monday through Friday. When working a five 8-hour day schedule and an Employer is prevented from working forty (40) hours Monday through Friday, or any part thereof, by reason of inclement weather, Saturday or any part thereof may be worked as a make-up day at the straight time rate. If an Employer is working a four 10-hour day schedule and loses a day due to inclement weather, he may work 10 hours Friday at straight time. All hours worked over the 40 hours Monday through Friday will be paid at 1 ½ overtime rate. A workday shift is to begin at the option of the Employer, between 6:00 a.m. and not later than 9:00 a.m. However, the project starting time may be advanced or delayed if required. If workmen are required to work the enumerated holidays or days observed as such or Sundays, they shall receive double (2) the regular rate of pay for such work. Overtime shall be computed at one-half (1/2) hour intervals. Shift: The Contractor may elect to work one, two or three shifts on any work. When operating on more than one shift, the shifts shall be known as the day shift, swing shift, and graveyard shift as such terms are recognized in the industry. When two shifts are worked on any operation, the shifts will consist of eight (8) or ten (10) hours exclusive of lunchtime. When three shifts are worked the first day or day shift will consist of eight (8) hours exclusive of lunchtime. The second or swing shift shall consist of seven and one-half (7 1/2) hours work for eight hours pay, exclusive of lunchtime, and the third or the graveyard shift shall consist of seven (7) hours work for eight (8) hours pay, exclusive of the lunchtime. All time in excess of normal shifts shall be considered overtime. Multiple shift (the two or three shift) operation will not be construed on the entire project if at anytime it is deemed advisable and necessary for the Employer to multiple shift a specific operation. However, no shift shall be started between midnight and six a.m. except the graveyard shift on a three-shift operation, or except in an unusual or emergency situation. If an Employer starts a shift between midnight and 6 a.m. except the graveyard shift on a three-shift operation, he shall reimburse all employees for the entire shift at the double time rate. Completion of the second shift on a two-shift operation or completion of the graveyard shift on a three-shift operation that carries over into Saturday morning, shall be at the straight time rate. Overtime shall be computed at ½ hour intervals.

**NO. 9:** Eight (8) hours shall constitute a work day between the hours of 7:00 a.m. and 4:30 p.m. Forty (40) hours within five (5) days, Monday through Friday inclusive, shall constitute the work week. Work performed in the 9th and 10th hour, Monday through Friday, shall be paid at time and one-half (1½) the regular straight time rate of pay. Contractor has the option to pay two (2) hours per day at the time and one-half (1½) the regular straight time rate of pay between the hours of 6:00 a.m. and 5:30 p.m., Monday through Friday. Work performed in the first eight (8) hours on Saturday shall be paid at the rate of one and eight tenths (1.8) the regular straight time rate. Work performed outside these hours and on Sundays and recognized legal holidays, or days celebrated as such, shall be paid for at the rate of double (2) time.

**NO. 21:** Means the regular workday for which employees shall be compensated at straight time hourly rate of pay shall, unless otherwise provided for, begin at 8:00 a.m. and end at 4:30 p.m. However, the project starting time may be advanced or delayed at the discretion of the Employer. At the discretion of the Employer, when working a five (5) day eight (8) hour schedule, Saturday may be used for a make-up day. If an Employer is prohibited from working on a holiday, that employer may work the following Saturday at the straight time rate. However, the Employer may have the option to schedule his work from Monday through Thursday at ten (10) hours per day at the straight time rate of pay with all hours in excess of ten (10) hours in any one day to be paid at the applicable overtime rate. If the Employer elects to work from Monday through Thursday and is stopped due to circumstances beyond his control, he shall have the option to work Friday or Saturday at the straight time rate of pay to complete his forty (40) hours. If an Employer is prohibited from working on a holiday, that Employer may work the following Friday or Saturday at the straight time rate. Overtime will be at one and one-half (1½) times the regular rate. If workmen are required to work the enumerated holidays or days observed as such, or Sundays, they shall receive double (2) the regular rate of pay for such work.

**REPLACEMENT PAGE  
BOONE COUNTY  
OVERTIME SCHEDULE - HEAVY CONSTRUCTION**

**NO. 23:** Means the regular workweek shall start on Monday and end on Friday, except where the Employer elects to work Monday through Thursday, (10) hours per day. All work over ten (10) hours in a day or forty (40) hours in a week shall be at the overtime rate of one and one-half (1½) times the regular hourly rate. The regular workday shall be either eight (8) or ten (10) hours. If a job can't work forty (40) hours Monday through Friday because of inclement weather or other conditions beyond the control of the Employer, Friday or Saturday may be worked as a make-up day at straight time (if working 4-10's). Saturday may be worked as a make-up day at straight time (if working 5-8's). An Employer, who is working a four (4) ten (10) hour day work schedule may use Friday as a make-up day when a workday is lost due to a holiday. A workday is to begin at the option of the Employer but not later than 11:00 a.m. except when inclement weather, requirements of the owner or other conditions beyond the reasonable control of the Employer prevent work. Except as worked as a make-up day, time on Saturday shall be worked at one and one-half (1½) times the regular rate. Work performed on Sunday shall be paid at two (2) times the regular rate. Work performed on recognized holidays or days observed as such, shall also be paid at the double (2) time rate of pay. **For all overtime hours worked during the week or on Saturday \$14.55 of the fringe benefits portion of the prevailing wage shall be paid at time and one-half (1½). For all overtime hours worked on Sundays or recognized holidays \$14.55 of the fringe benefits portion of the prevailing wage shall be paid double time. The remaining \$.50 of the fringe benefit portion of the prevailing wage shall be paid at straight time.**

**NO. 25:** Means a regular work week of forty (40) hours, starting on Monday and ending on Friday. The regular work day shall be either eight (8) or ten (10) hours. If a crew is prevented from working forty (40) hours Monday through Friday, or any part thereof by reason of inclement weather, Saturday or any part thereof maybe worked as a make-up day at the straight time rate. Employees who are part of a regular crew on a make-up day, notwithstanding the fact that they may not have been employed the entire week, shall work Saturday at the straight time rate. A work day is to begin between 6:00 a.m. and 9:00 a.m. However, the project starting time maybe advanced or delayed if mutually agreed to by the interest parties. All hours worked on recognized holidays, or days observed as such, double (2) time shall be paid.

**NO. 28:** Means a regular work week of forty (40) hours will start on Monday and end on Friday. The regular work day shall be either eight (8) or ten (10) hours. If a crew is prevented from working forty (40) hours Monday through Friday, or any part thereof by reason of inclement weather, Saturday or any part thereof may be worked as a make-up day at the straight time rate. Employees who are part of a regular crew on a make-up day, notwithstanding the fact that they may not have been employed the entire week, shall work Saturday at the straight time rate. A workday is to begin between 6:00 a.m. and 9:00 a.m. However, the project starting time may be advanced or delayed if mutually agreed to by the interest parties. For all time worked on recognized holidays, or days observed as such, double (2) time shall be paid.

**NO. 32:** Means the overtime rate shall be time and one-half the regular rate for work over forty (40) hours per week. Sundays and Holidays shall be paid at double the straight time rate.

**BOONE COUNTY  
HOLIDAY SCHEDULE – HEAVY CONSTRUCTION**

**NO. 4:** All work performed on New Year's Day, Memorial Day, Independence Day, Labor Day, Thanksgiving Day, Christmas Day, or observed as such, shall be paid at the double time rate of pay. When a Holiday falls on a Sunday, Monday shall be observed. No work shall be performed on Labor Day, except in case of jeopardy to life or property. This is applied to protect Labor Day.

**NO. 5:** The following days are recognized as holidays: New Year's Day, Memorial Day, Fourth of July, Labor Day, Thanksgiving Day and Christmas Day. If a holiday falls on a Sunday, it shall be observed on the following Monday. If a holiday falls on a Saturday, it shall be observed on the preceding Friday. No work shall be performed on Labor Day except in case of jeopardy to work under construction. This rule is applied to protect Labor Day. When a holiday falls during the normal work week, Monday through Friday, it shall be counted as eight (8) hours toward a forty (40) hour week; however, no reimbursement for this eight (8) hours is to be paid the workman unless worked. If workmen are required to work the above recognized holidays or days observed as such, or Sundays, they shall receive double (2) the regular rate of pay for such work. The above shall apply to the four 10's Monday through Friday work week. The ten (10) hours shall be applied to the forty (40) hour work week.

**NO. 12:** All work performed on New Year's Day, Memorial Day, Fourth of July, Labor Day, Veteran's Day, Thanksgiving Day, Christmas Day, or days celebrated as such, shall be paid at the double time rate of pay. When one of the foregoing holidays falls on Sunday, it shall be celebrated on the following Monday. When one of the foregoing holidays falls on Saturday, it shall be celebrated on the Friday before the holiday.

**NO. 16:** The following days are recognized as holidays: New Year's Day, Memorial Day, Fourth of July, Labor Day, Thanksgiving Day and Christmas Day. If a holiday falls on Sunday, it shall be observed on the following Monday. If a holiday falls on Saturday, it shall be observed on the preceding Friday. No work shall be performed on Labor Day except in case of jeopardy to work under construction. This rule is applied to protect Labor Day. When a holiday falls during the normal work week, Monday through Friday, it shall be counted as eight (8) hours toward the forty (40) hour week; however, no reimbursement for this eight (8) hours is to be paid to the worker unless worked. If workers are required to work the above recognized holidays or days observed as such, they shall receive double (2) the regular rate of pay for such work.

**NO. 21:** The following days are recognized as holidays: New Year's Day, Memorial Day, Independence Day, Labor Day, Thanksgiving Day and Christmas Day. If a holiday falls on a Sunday, it shall be observed on the following Monday. No work shall be performed on Labor Day except in case of jeopardy to work under construction. This rule is applied to protect Labor Day. When a holiday falls during the normal work week, Monday through Friday, it shall be counted as eight (8) hours toward the forty (40) hour week; however, no reimbursement for this eight (8) hours is to be paid the workman unless worked. An Employer working a four (4) day, ten (10) hour schedule may use Friday as a make-up day when an observed holiday occurs during the work week. Employees have the option to work that make-up day. If workmen are required to work the above enumerated holidays, or days observed as such, they shall receive double (2) the regular rate of pay for such work.

**NO. 27:** The following days are recognized as holidays: New Year's Day, Memorial Day, Independence Day, Labor Day, Thanksgiving Day and Christmas Day. If a holiday falls on a Sunday, it shall be observed on the following Monday. No work shall be performed on Labor Day except in case of jeopardy to work under construction. This rule is applied to protect Labor Day. When a holiday falls during the normal work week, Monday through Friday, it shall be counted as eight (8) hours toward the forty (40) hour week; however, no reimbursement for this eight (8) hours is to be paid the workmen unless worked. An Employer working a four (4) day, ten (10) hour schedule may use Friday as a make up day when an observed holiday occurs during the work week. Employees have the option to work that make up day. If workmen are required to work the above enumerated holidays, or days observed as such, they shall receive double (2) the regular rate of pay for such work.

**NO. 31:** All work performed on New Year's Day, Presidents' Day, Veterans' Day, Good Friday, Decoration Day, Fourth of July, Labor Day, Christmas Eve Day, Christmas Day, Thanksgiving Day and Day after Thanksgiving or days celebrated for the same.



**AFFIDAVIT OF COMPLIANCE WITH THE PREVAILING WAGE LAW**  
**(To be returned at end of project)**

Before me, the undersigned Notary Public, in and for the County of \_\_\_\_\_

State of \_\_\_\_\_, personally came and appeared (name and title)

\_\_\_\_\_ of the (name of company)

\_\_\_\_\_ (a corporation) (a partnership) (a proprietorship)

and after being duly sworn did depose and say that all provisions and requirements set out in Chapter 290 Sections 290.210 through and including 290.340, Missouri Revised Statutes, pertaining to the payment of wages to workmen employed on public works projects have been fully satisfied and there has been no exception to the full and complete compliance with said provisions and requirements and with Wage Determination NO. \_\_\_\_\_ issued by the Division of Labor Standards on the \_\_\_\_\_ day of \_\_\_\_\_ 20\_\_\_\_, in carrying out the Contract and work in connection with

(name of project) \_\_\_\_\_ located at

(name of institution) \_\_\_\_\_ in \_\_\_\_\_ County,

Missouri and completed on the \_\_\_\_\_ day of \_\_\_\_\_, 20\_\_\_\_\_.

\_\_\_\_\_  
Signature

Subscribed and sworn to me this \_\_\_\_\_ day of \_\_\_\_\_, 20\_\_\_\_\_.

My commission expires \_\_\_\_\_, 20\_\_\_\_\_.

\_\_\_\_\_  
Notary Public





***“No Bid” Response Form***

**Boone County Purchasing**  
613 E. Ash, Room 110  
Columbia, MO 65201

Melinda Bobbitt, Director of Purchasing  
(573) 886-4391 – Fax: (573) 886-4390

**“NO BID RESPONSE FORM”**

**NOTE: COMPLETE AND RETURN THIS FORM ONLY IF YOU DO NOT WANT TO  
SUBMIT A BID**

If you do not wish to respond to this bid request, but would like to remain on the Boone County vendor list for this service/commodity, please remove form and return to the Purchasing Department by mail or fax.

If you would like to FAX this “No Bid” Response Form to our office, the FAX number is (573) 886-4390.

**Bid: 77-10DEC15 – Radio Tower Erection at Battle School Project**

Business Name: \_\_\_\_\_

Address: \_\_\_\_\_  
\_\_\_\_\_  
\_\_\_\_\_

Telephone: \_\_\_\_\_

Contact: \_\_\_\_\_

Date: \_\_\_\_\_

Reason(s) for not bidding:

\_\_\_\_\_  
\_\_\_\_\_  
\_\_\_\_\_

**NOTICE: ALL PARTS ARE TO BE INVENTORIED AND ANY SHORTAGES REPORTED WITHIN 48 HOURS OF DELIVERY. SHORTAGES REPORTED AFTER THIS TIME PERIOD WILL BE CHARGED TO THE CONTRACTOR.**

**CALL 800/369-6690 ASK FOR THE CONTRACTS DEPARTMENT**

**DRAWING LIST**

MONOPOLE ERECTION	130727-MM
MONOPOLE FOUNDATION(S)	130727-F1 130727-F2
MONOPOLE FABRICATION	130727-01
MOUNTS: TRI-COLLAR	C10112300 C10112301
12' LP PLATFORM WITH HANDRAIL	C10851001 C10116813
3' SIDEARM	C10119103 C10151103
BILL OF MATERIALS	BOM-1

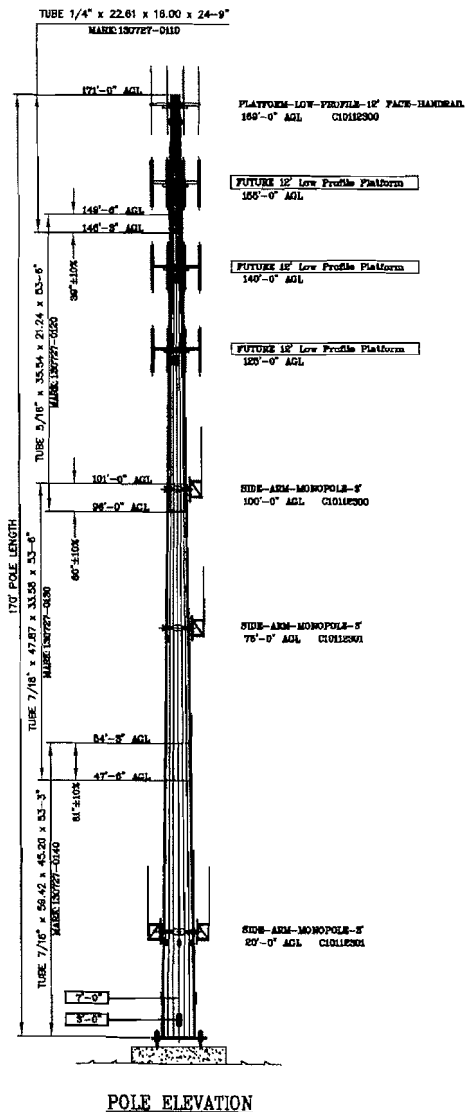

PLATFORM-LOW-PROFILE-12' FACE-HANDRAIL  
168'-0" AGL C10112300

FUTURE 12' Low Profile Platform  
155'-0" AGL

FUTURE 12' Low Profile Platform  
140'-0" AGL

FUTURE 12' Low Profile Platform  
120'-0" AGL

SIDE-ARM-MONOPOLE-F  
100'-0" AGL C10112300

SIDE-ARM-MONOPOLE-F  
75'-0" AGL C10112301

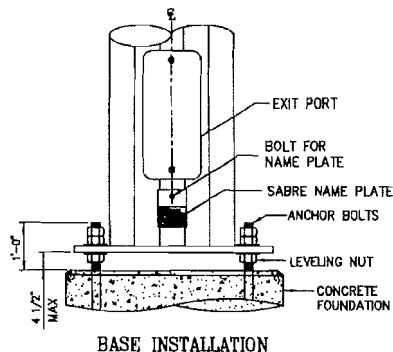
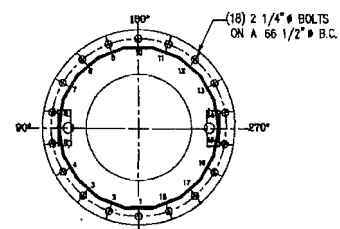
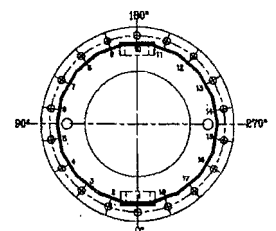

**BOLT INSTALLATION DETAILS**

1. INSTALLATION OF BOLTS: BOLTS FOR TOWERS AND ANTENNAS SHALL BE INSTALLED WITH THE NUTS FACING TO THE OUTSIDE AND/OR TO THE TOP OF THE TOWER, UNLESS PROHIBITED BY LACK OF CLEARANCE.
2. TIGHTENING OF BOLTS: ALL HIGH STRENGTH BOLTS SHALL BE TIGHTENED TO A SNUG-TIGHT CONDITION, AS DEFINED BY AISC.
3. NUT LOCKING DEVICE: ALL NUTS SHALL BE EQUIPPED WITH SOME TYPE OF NUT LOCKING DEVICE. SEE THE INDIVIDUAL DRAWINGS FOR THE TYPE OF NUT LOCKING DEVICE TO BE USED FOR EACH INDIVIDUAL APPLICATION.

UNLESS OTHERWISE SPECIFIED ALL DIMENSIONS INCLUDE FINISHES AND ARE IN INCHES		MATERIAL:		<p>Towers and Poles</p>	BOONE COUNTY Battle School, MO	
TOLERANCES: FRACTIONS ± 1/16" ANGLES ± 1/2 DEG DECIMALS ± .010"		TOLERANCES DO NOT APPLY TO RAW MATERIAL			171.00 MONOPOLE	
<p><b>CONFIDENTIAL</b></p> <p>This Document and the information contained herein is the confidential trade secret property of Sabre Communication Corporation ("Sabre") and must not be reproduced, copied or used, in whole or in part, for any purpose without the prior written consent of Sabre. ©2015 Sabre Communications Corporation. All rights reserved.</p>				<p><b>CONFIDENTIAL</b></p> <p>This Document and the information contained herein is the confidential trade secret property of Sabre Communication Corporation ("Sabre") and must not be reproduced, copied or used, in whole or in part, for any purpose without the prior written consent of Sabre. ©2015 Sabre Communications Corporation. All rights reserved.</p>		
JOB 130727		SIZE B	DRAWING NO. 130727-MM		REV 1	
DATE 27Oct15		DRAWN BY DLK		SCALE N.T.S.		
CHECKED BY WJ		130727-E		PAGE 1 of 1		

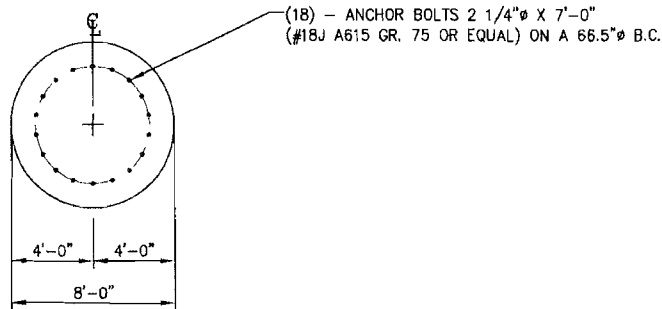

(18) - ANCHOR BOLTS 2 1/4"φ X 7'-0"  
 (#18J A615 GR. 75 OR EQUAL) ON A 66.5"φ B.C.

PLAN VIEW

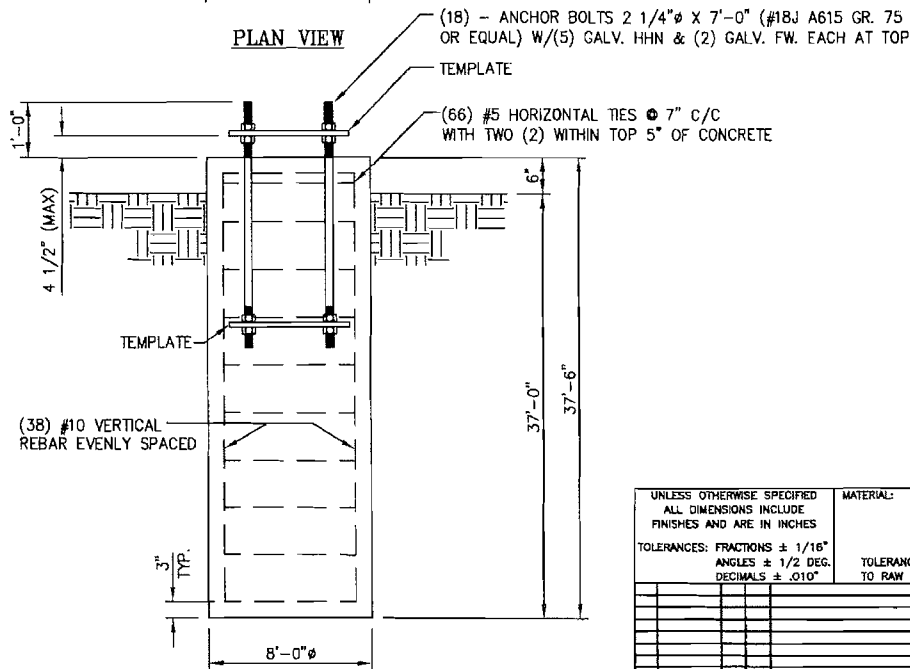

(18) - ANCHOR BOLTS 2 1/4"φ X 7'-0" (#18J A615 GR. 75 OR EQUAL) W/(5) GALV. HHN & (2) GALV. FW. EACH AT TOP

TEMPLATE

(66) #5 HORIZONTAL TIES φ 7" C/C WITH TWO (2) WITHIN TOP 5" OF CONCRETE

(38) #10 VERTICAL REBAR EVENLY SPACED

ELEVATION VIEW

REINFORCING STEEL SCHEDULE

LOCATION	NO REQ'D.	BAR SPC'G.	SIZE	CUT LGTH.	TOTAL LGTH.	TOTAL WT.	SHAPE
PIER VERTICAL REINFORCING	38	NOTED ON DWG.	#10	37'-0"	1406'-0"	6050 LBS.	STRAIGHT
PIER TIES	66	NOTED ON DWG.	#5	25'-2"	1661'-0"	1732 LBS.	
TOTAL REBAR WT.						7782 LBS.	

TOP & BOTTOM TEMPLATES  
 PART NO.: 130727-9001

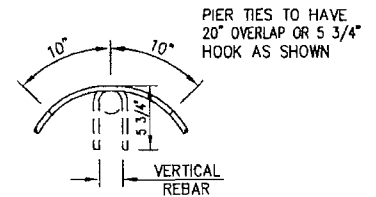

PIER TIES TO HAVE 20" OVERLAP OR 5 3/4" HOOK AS SHOWN

PIER TIE HOOK DETAIL

GENERAL NOTES:

- ALL ANCHOR BOLTS AND VERTICAL REINFORCING BARS ARE TO BE SECURELY TIED BEFORE CONCRETE IS PLACED SO THEY WILL REMAIN PARALLEL TO THE CENTERLINE OF THE PIER.
- THE GROUND ELEVATION SHALL BE A MAXIMUM OF 6" BELOW THE TOP OF THE PIER.
- ALL EXPOSED CONCRETE CORNERS ARE TO BE CHAMFERED 3/4 INCH.
- ALL REINFORCING STEEL SHALL CONFORM TO ASTM A615 GRADE 60 DEFORMED BARS.
- CONCRETE SHALL HAVE A MINIMUM 28 DAY COMPRESSIVE STRENGTH OF 4000 PSI, IN ACCORDANCE WITH ACI 318-05.
- REINFORCING STEEL TO HAVE A 3" MINIMUM CONCRETE COVER.
- FOUNDATION DESIGN IS BASED ON THE GEOTECHNICAL REPORT BY CROCKETT, PROJECT NO. C15046, DATED JULY 20, 2015.
- ANCHOR BOLTS 2 1/4"φ X 7'-0" (#18J A615 GR. 75 OR EQUAL) ON A 66.5"φ BOLT CIRCLE (18 REQ'D).
- CONCRETE REQUIRED 69.81 CUBIC YARDS.
- SEE THE GEOTECHNICAL REPORT FOR DRILLED PIER INSTALLATION REQUIREMENTS, IF SPECIFIED.
- THE FOUNDATION IS BASED ON THE FOLLOWING FACTORED LOADS:  
 MOMENT (KIP-FT) = 6107.2  
 AXIAL (KIPS) = 63.28  
 SHEAR (KIPS) = 48.63

UNLESS OTHERWISE SPECIFIED ALL DIMENSIONS INCLUDE FINISHES AND ARE IN INCHES		MATERIAL:	
TOLERANCES: FRACTIONS ± 1/16" ANGLES ± 1/2 DEG. DECIMALS ± .010"		TOLERANCES DO NOT APPLY TO RAW MATERIAL	
REV	DATE	DRW/CHK	DESCRIPTION
1	11/9/15	DLK/WJ	REVISED POLE HEIGHT AND NOTE 11



**CONFIDENTIAL**  
 This document and the information contained herein is the confidential trade secret property of Sabre Communications Corporation ("Sabre") and must not be reproduced, copied or used, in whole or in part, for any purpose without the prior written consent of Sabre.  
 © 2015 Sabre Communications Corporation. All rights reserved.

BOONE COUNTY  
 BATTLE SCHOOL, MO  
 171.00 MONOPOLE

JOB NO. 130727	SIZE B	DRAWING NO. 130727-F1	REV 1
DATE 10/27/15	DRAWN BY DLK	CHECKED BY WJ	SCALE None
PAGE 1 OF 1			

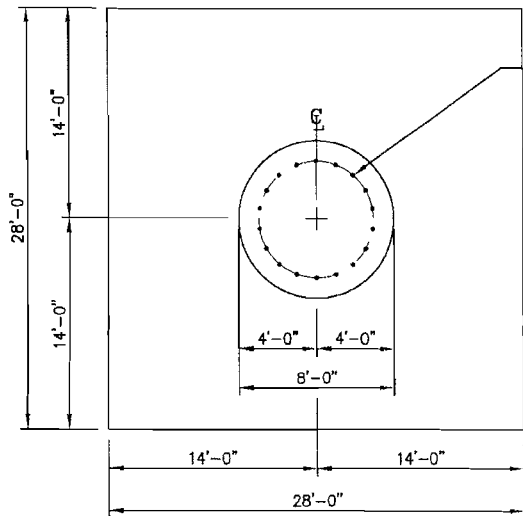

(18) - ANCHOR BOLTS 2 1/4"φ X 7'-0"  
 (#18J A615 GR. 75 OR EQUAL) ON A 66.5"φ B.C.

TOP & BOTTOM TEMPLATES  
 PART NO.: 130727-9001

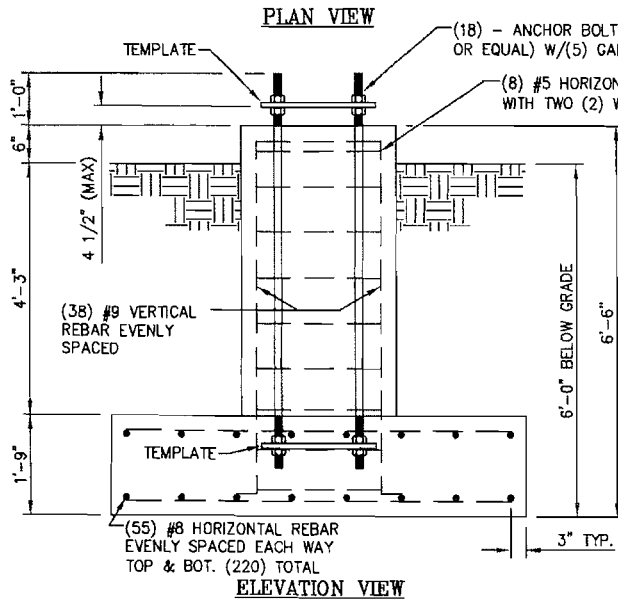

(18) - ANCHOR BOLTS 2 1/4"φ X 7'-0" (#18J A615 GR. 75 OR EQUAL) W/(5) GALV. H.H.N. & (2) GALV. FW. EACH AT TOP  
 (8) #5 HORIZONTAL TIES @ 12" C/C WITH TWO (2) WITHIN TOP 5" OF CONCRETE

(55) #8 HORIZONTAL REBAR  
 EVENLY SPACED EACH WAY  
 TOP & BOT. (220) TOTAL

ELEVATION VIEW

REINFORCING STEEL SCHEDULE

LOCATION	NO REQ'D.	BAR SPC'G.	SIZE	CUT LGTH.	TOTAL LGTH.	TOTAL WT.	SHAPE
PAD HORIZONTAL REINFORCING	220	NOTED ON DWG.	#8	27'-6"	6050'-0"	16154 LBS.	STRAIGHT
PIER VERTICAL REINFORCING	38	NOTED ON DWG.	#9	7'-4"	278'-8"	947 LBS.	SEE REBAR DETAIL
PIER TIES	8	NOTED ON DWG.	#5	25'-2"	201'-4"	210 LBS.	
TOTAL REBAR WT.						17311 LBS.	

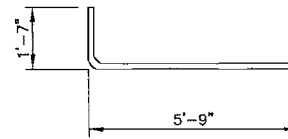

REBAR DETAIL "A"

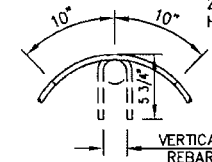

PIER TIE HOOK DETAIL

PIER TIES TO HAVE 20" OVERLAP OR 5 3/4" HOOK AS SHOWN

GENERAL NOTES:

- ALL ANCHOR BOLTS AND VERTICAL REINFORCING BARS ARE TO BE SECURELY TIED BEFORE CONCRETE IS PLACED SO THEY WILL REMAIN PARALLEL TO THE CENTERLINE OF THE PIER.
- THE GROUND ELEVATION SHALL BE A MAXIMUM OF 6" BELOW THE TOP OF THE PIER.
- ALL EXPOSED CONCRETE CORNERS ARE TO BE CHAMFERED 3/4 INCH.
- ALL REINFORCING STEEL SHALL CONFORM TO ASTM A615 GRADE 60 DEFORMED BARS.
- CONCRETE SHALL HAVE A MINIMUM 28 DAY COMPRESSIVE STRENGTH OF 4500 PSI, IN ACCORDANCE WITH ACI 318-05.
- REINFORCING STEEL TO HAVE A 3" MINIMUM CONCRETE COVER.
- FOUNDATION DESIGN IS BASED ON THE GEOTECHNICAL REPORT BY CROCKETT, PROJECT NO. G15045, DATED JULY 20, 2015.
- ANCHOR BOLTS 2 1/4"φ X 7'-0" (#18J A615 GR. 75 OR EQUAL) ON A 66.5"φ BOLT CIRCLE (18 REQ'D).
- CONCRETE REQUIRED 59.66 CUBIC YARDS.
- SEE THE GEOTECHNICAL REPORT FOR COMPACTION REQUIREMENTS, IF SPECIFIED.
- THE FOUNDATION IS BASED ON THE FOLLOWING FACTORED LOADS:  
 MOMENT (KIP-FT) = 6107.2  
 AXIAL (KIPS) = 63.28  
 SHEAR (KIPS) = 48.63
- 4.25 FT OF SOIL COVER IS REQUIRED OVER THE ENTIRE AREA OF THE FOUNDATION SLAB.

UNLESS OTHERWISE SPECIFIED ALL DIMENSIONS INCLUDE FINISHES AND ARE IN INCHES		MATERIAL:	
TOLERANCES: FRACTIONS ± 1/16" ANGLES ± 1/2 DEG. DECIMALS ± .010"		TOLERANCES DO NOT APPLY TO RAW MATERIAL	
REV	DATE	DRW/CHK	DESCRIPTION
	11/07/15	DLK/WJ	REVISED POLE HEIGHT AND NOTE 11

**Sabre Industries**  
Towers and Poles

**CONFIDENTIAL**  
This document and the information contained herein is the confidential trade secret property of Sabre Communications Corporation ("Sabre") and must not be reproduced, copied or used, in whole or in part, for any purpose without the prior written consent of Sabre.  
© 2015 Sabre Communications Corporation. All rights reserved.

BOONE COUNTY  
 BATTLE SCHOOL, MO  
 171.00 MONOPOLE

JOB NO. 130727	SIZE B	DRAWING NO. 130727-F2	REV 1
DATE 10/27/15			
DRAWN BY DLK			
CHECKED BY WJ		SCALE None	PAGE 1 OF 1

ITEM	QTY	MARK NO.	REL. OF MATERIAL DESCRIPTION	UNIT	MARK	REMARKS
1	1	130727-010	BASE PLATE	1	130727-010	
2	1	130727-011	ACCESS PORT	1	130727-011	
3	1	130727-012	CLIMBING SYSTEM	1	130727-012	
4	1	130727-013	SAFETY CLAMP	1	130727-013	
5	1	130727-014	STEP BOLTS	1	130727-014	
6	1	130727-015	CLIMBING SYSTEM	1	130727-015	
7	1	130727-016	SAFETY CLAMP	1	130727-016	
8	1	130727-017	STEP BOLTS	1	130727-017	
9	1	130727-018	CLIMBING SYSTEM	1	130727-018	
10	1	130727-019	SAFETY CLAMP	1	130727-019	
11	1	130727-020	STEP BOLTS	1	130727-020	
12	1	130727-021	CLIMBING SYSTEM	1	130727-021	
13	1	130727-022	SAFETY CLAMP	1	130727-022	
14	1	130727-023	STEP BOLTS	1	130727-023	
15	1	130727-024	CLIMBING SYSTEM	1	130727-024	
16	1	130727-025	SAFETY CLAMP	1	130727-025	
17	1	130727-026	STEP BOLTS	1	130727-026	
18	1	130727-027	CLIMBING SYSTEM	1	130727-027	
19	1	130727-028	SAFETY CLAMP	1	130727-028	
20	1	130727-029	STEP BOLTS	1	130727-029	
21	1	130727-030	CLIMBING SYSTEM	1	130727-030	
22	1	130727-031	SAFETY CLAMP	1	130727-031	
23	1	130727-032	STEP BOLTS	1	130727-032	
24	1	130727-033	CLIMBING SYSTEM	1	130727-033	
25	1	130727-034	SAFETY CLAMP	1	130727-034	
26	1	130727-035	STEP BOLTS	1	130727-035	
27	1	130727-036	CLIMBING SYSTEM	1	130727-036	
28	1	130727-037	SAFETY CLAMP	1	130727-037	
29	1	130727-038	STEP BOLTS	1	130727-038	
30	1	130727-039	CLIMBING SYSTEM	1	130727-039	
31	1	130727-040	SAFETY CLAMP	1	130727-040	
32	1	130727-041	STEP BOLTS	1	130727-041	
33	1	130727-042	CLIMBING SYSTEM	1	130727-042	
34	1	130727-043	SAFETY CLAMP	1	130727-043	
35	1	130727-044	STEP BOLTS	1	130727-044	
36	1	130727-045	CLIMBING SYSTEM	1	130727-045	
37	1	130727-046	SAFETY CLAMP	1	130727-046	
38	1	130727-047	STEP BOLTS	1	130727-047	
39	1	130727-048	CLIMBING SYSTEM	1	130727-048	
40	1	130727-049	SAFETY CLAMP	1	130727-049	
41	1	130727-050	STEP BOLTS	1	130727-050	
42	1	130727-051	CLIMBING SYSTEM	1	130727-051	
43	1	130727-052	SAFETY CLAMP	1	130727-052	
44	1	130727-053	STEP BOLTS	1	130727-053	
45	1	130727-054	CLIMBING SYSTEM	1	130727-054	
46	1	130727-055	SAFETY CLAMP	1	130727-055	
47	1	130727-056	STEP BOLTS	1	130727-056	
48	1	130727-057	CLIMBING SYSTEM	1	130727-057	
49	1	130727-058	SAFETY CLAMP	1	130727-058	
50	1	130727-059	STEP BOLTS	1	130727-059	
51	1	130727-060	CLIMBING SYSTEM	1	130727-060	
52	1	130727-061	SAFETY CLAMP	1	130727-061	
53	1	130727-062	STEP BOLTS	1	130727-062	
54	1	130727-063	CLIMBING SYSTEM	1	130727-063	
55	1	130727-064	SAFETY CLAMP	1	130727-064	
56	1	130727-065	STEP BOLTS	1	130727-065	
57	1	130727-066	CLIMBING SYSTEM	1	130727-066	
58	1	130727-067	SAFETY CLAMP	1	130727-067	
59	1	130727-068	STEP BOLTS	1	130727-068	
60	1	130727-069	CLIMBING SYSTEM	1	130727-069	
61	1	130727-070	SAFETY CLAMP	1	130727-070	
62	1	130727-071	STEP BOLTS	1	130727-071	
63	1	130727-072	CLIMBING SYSTEM	1	130727-072	
64	1	130727-073	SAFETY CLAMP	1	130727-073	
65	1	130727-074	STEP BOLTS	1	130727-074	
66	1	130727-075	CLIMBING SYSTEM	1	130727-075	
67	1	130727-076	SAFETY CLAMP	1	130727-076	
68	1	130727-077	STEP BOLTS	1	130727-077	
69	1	130727-078	CLIMBING SYSTEM	1	130727-078	
70	1	130727-079	SAFETY CLAMP	1	130727-079	
71	1	130727-080	STEP BOLTS	1	130727-080	
72	1	130727-081	CLIMBING SYSTEM	1	130727-081	
73	1	130727-082	SAFETY CLAMP	1	130727-082	
74	1	130727-083	STEP BOLTS	1	130727-083	
75	1	130727-084	CLIMBING SYSTEM	1	130727-084	
76	1	130727-085	SAFETY CLAMP	1	130727-085	
77	1	130727-086	STEP BOLTS	1	130727-086	
78	1	130727-087	CLIMBING SYSTEM	1	130727-087	
79	1	130727-088	SAFETY CLAMP	1	130727-088	
80	1	130727-089	STEP BOLTS	1	130727-089	
81	1	130727-090	CLIMBING SYSTEM	1	130727-090	
82	1	130727-091	SAFETY CLAMP	1	130727-091	
83	1	130727-092	STEP BOLTS	1	130727-092	
84	1	130727-093	CLIMBING SYSTEM	1	130727-093	
85	1	130727-094	SAFETY CLAMP	1	130727-094	
86	1	130727-095	STEP BOLTS	1	130727-095	
87	1	130727-096	CLIMBING SYSTEM	1	130727-096	
88	1	130727-097	SAFETY CLAMP	1	130727-097	
89	1	130727-098	STEP BOLTS	1	130727-098	
90	1	130727-099	CLIMBING SYSTEM	1	130727-099	
91	1	130727-100	SAFETY CLAMP	1	130727-100	
92	1	130727-101	STEP BOLTS	1	130727-101	
93	1	130727-102	CLIMBING SYSTEM	1	130727-102	
94	1	130727-103	SAFETY CLAMP	1	130727-103	
95	1	130727-104	STEP BOLTS	1	130727-104	
96	1	130727-105	CLIMBING SYSTEM	1	130727-105	
97	1	130727-106	SAFETY CLAMP	1	130727-106	
98	1	130727-107	STEP BOLTS	1	130727-107	
99	1	130727-108	CLIMBING SYSTEM	1	130727-108	
100	1	130727-109	SAFETY CLAMP	1	130727-109	
101	1	130727-110	STEP BOLTS	1	130727-110	
102	1	130727-111	CLIMBING SYSTEM	1	130727-111	
103	1	130727-112	SAFETY CLAMP	1	130727-112	
104	1	130727-113	STEP BOLTS	1	130727-113	
105	1	130727-114	CLIMBING SYSTEM	1	130727-114	
106	1	130727-115	SAFETY CLAMP	1	130727-115	
107	1	130727-116	STEP BOLTS	1	130727-116	
108	1	130727-117	CLIMBING SYSTEM	1	130727-117	
109	1	130727-118	SAFETY CLAMP	1	130727-118	
110	1	130727-119	STEP BOLTS	1	130727-119	
111	1	130727-120	CLIMBING SYSTEM	1	130727-120	
112	1	130727-121	SAFETY CLAMP	1	130727-121	
113	1	130727-122	STEP BOLTS	1	130727-122	
114	1	130727-123	CLIMBING SYSTEM	1	130727-123	
115	1	130727-124	SAFETY CLAMP	1	130727-124	
116	1	130727-125	STEP BOLTS	1	130727-125	
117	1	130727-126	CLIMBING SYSTEM	1	130727-126	
118	1	130727-127	SAFETY CLAMP	1	130727-127	
119	1	130727-128	STEP BOLTS	1	130727-128	
120	1	130727-129	CLIMBING SYSTEM	1	130727-129	
121	1	130727-130	SAFETY CLAMP	1	130727-130	
122	1	130727-131	STEP BOLTS	1	130727-131	
123	1	130727-132	CLIMBING SYSTEM	1	130727-132	
124	1	130727-133	SAFETY CLAMP	1	130727-133	
125	1	130727-134	STEP BOLTS	1	130727-134	
126	1	130727-135	CLIMBING SYSTEM	1	130727-135	
127	1	130727-136	SAFETY CLAMP	1	130727-136	
128	1	130727-137	STEP BOLTS	1	130727-137	
129	1	130727-138	CLIMBING SYSTEM	1	130727-138	
130	1	130727-139	SAFETY CLAMP	1	130727-139	
131	1	130727-140	STEP BOLTS	1	130727-140	
132	1	130727-141	CLIMBING SYSTEM	1	130727-141	
133	1	130727-142	SAFETY CLAMP	1	130727-142	
134	1	130727-143	STEP BOLTS	1	130727-143	
135	1	130727-144	CLIMBING SYSTEM	1	130727-144	
136	1	130727-145	SAFETY CLAMP	1	130727-145	
137	1	130727-146	STEP BOLTS	1	130727-146	
138	1	130727-147	CLIMBING SYSTEM	1	130727-147	
139	1	130727-148	SAFETY CLAMP	1	130727-148	
140	1	130727-149	STEP BOLTS	1	130727-149	
141	1	130727-150	CLIMBING SYSTEM	1	130727-150	
142	1	130727-151	SAFETY CLAMP	1	130727-151	
143	1	130727-152	STEP BOLTS	1	130727-152	
144	1	130727-153	CLIMBING SYSTEM	1	130727-153	
145	1	130727-154	SAFETY CLAMP	1	130727-154	
146	1	130727-155	STEP BOLTS	1	130727-155	
147	1	130727-156	CLIMBING SYSTEM	1	130727-156	
148	1	130727-157	SAFETY CLAMP	1	130727-157	
149	1	130727-158	STEP BOLTS	1	130727-158	
150	1	130727-159	CLIMBING SYSTEM	1	130727-159	
151	1	130727-160	SAFETY CLAMP	1	130727-160	
152	1	130727-161	STEP BOLTS	1	130727-161	
153	1	130727-162	CLIMBING SYSTEM	1	130727-162	
154	1	130727-163	SAFETY CLAMP	1	130727-163	
155	1	130727-164	STEP BOLTS	1	130727-164	
156	1	130727-165	CLIMBING SYSTEM	1	130727-165	
157	1	130727-166	SAFETY CLAMP	1	130727-166	
158	1	130727-167	STEP BOLTS	1	130727-167	
159	1	130727-168	CLIMBING SYSTEM	1	130727-168	
160	1	130727-169	SAFETY CLAMP	1	130727-169	
161						



C10112300 TRI-COLLAR ASSEMBLY (10"-40" MONOPOLE)

ITEM	QTY.	PART. NO.	DESCRIPTION	WEIGHT
1.	3	CW00835	WELDMENT, TRI-COLLAR (10"-40" MONOPOLE)	151
2.	6	C40094012	THREADED ROD ASSEMBLY 5/8 X 2'-9"	25
3.	6	C40094002	THREADED ROD ASSEMBLY 5/8 X 1'-6"	17
TOTAL WEIGHT				193

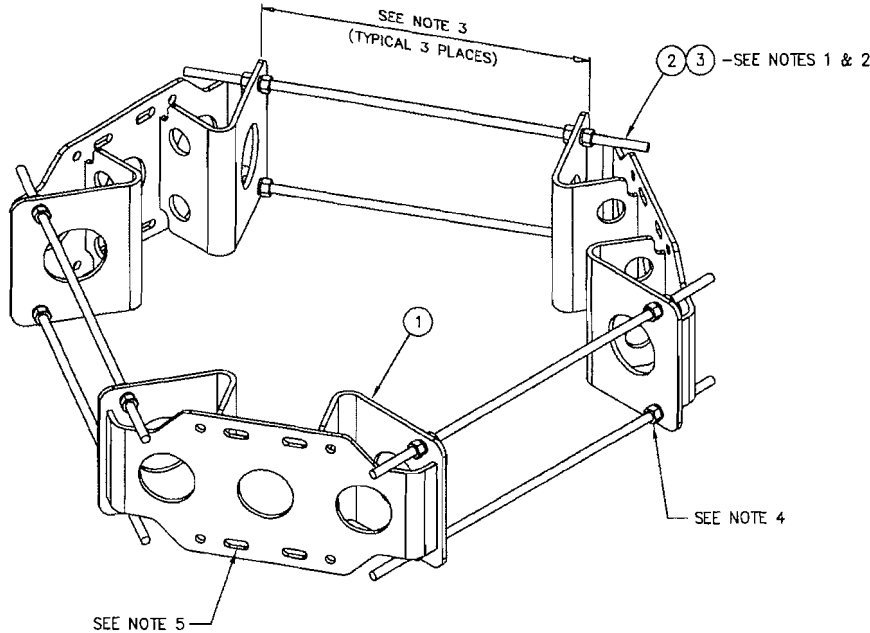

ISOMETRIC VIEW

NOTES:

1. THERE ARE (2) LENGTHS OF THREADED ROD SUPPLIED TO ACCOMMODATE DIAMETERS LISTED BELOW  
 USE 5/8 X 1'-6" THREADED ROD ASSEMBLY FOR 10"-24" MONOPOLE DIAMETERS  
 USE 5/8 X 2'-9" THREADED ROD ASSEMBLY FOR 24"-40" MONOPOLE DIAMETERS (SEE NOTE 2)
2. THREADED ROD MAY BE SHORTENED IF REQUIRED, FIELD CUT AND COLD GALV SPRAY TO SUIT.
3. THIS DISTANCE MUST BE EQUAL IN ALL (3) THREE LOCATIONS TO ENSURE THE STRUCTURAL INTEGRITY OF THE THREADED RODS AS WELL AS 120° SEPARATION.
4. FOR MONOPOLES 13" DIA. OR SMALLER, ONLY (1) ONE NUT AND (1) ONE LOCKWASHER ARE REQUIRED BETWEEN THE TRI-COLLAR BRACKETS.  
 FOR MONOPOLES LARGER THAN 13" DIA., (2) TWO NUTS AND (2) TWO LOCKWASHERS ARE REQUIRED BETWEEN THE TRI-COLLAR BRACKETS.
5. THE MOUNTING SLOTS NOTED WILL ACCOMMODATE 2 3/8"-4 1/2" O.D. MOUNTING PIPES.

UNLESS OTHERWISE SPECIFIED ALL DIMENSIONS INCLUDE FINISHES AND ARE IN INCHES		MATERIAL:
TOLERANCES: FRACTIONS ± 1/16" ANGLES ± 1/2 DEG. DECIMALS ± .010"		TOLERANCES DO NOT APPLY TO RAW MATERIAL
REV	DATE	DESCRIPTION
2	8/11/10	MLC WELDED ASSEMBLY 5/8 X 1'-6" THREADED ROD
1	1/26/10	MLC MLC REDRAWN IN AUTOCAD

**Sabre Industries**  
Towers and Poles

**CONFIDENTIAL**  
This document and the information contained herein is the confidential trade secret property of Sabre Communications Corporation ("Sabre") and must not be reproduced, copied or used, in whole or in part, for any purpose without the prior written consent of Sabre.  
© 2014 Sabre Communications Corporation. All rights reserved.

TRI-COLLAR BRACKET ASSEMBLY  
FOR MONOPOLES (10"-40" DIA.)  
(CIRCUMFERENCE 31.4" TO 125.7")

DATE	8/21/09	SIZE	B	DRAWING NO.	C10112300	REV	2
DRAWN BY	JV	SCALE	None	PAGE	1	OF 1	
CHECKED BY	MLC						



C10112301 TRI-COLLAR ASSEMBLY (12"-60" MONOPOLE)

ITEM	QTY.	PART. NO.	DESCRIPTION	WEIGHT
1.	3	CW00843	WELDMENT, TRI-COLLAR (12"-60" MONOPOLE)	294
2.	6	C40094010	THREADED ROD ASSEMBLY 3/4 X 4'-4"	36
TOTAL WEIGHT				330

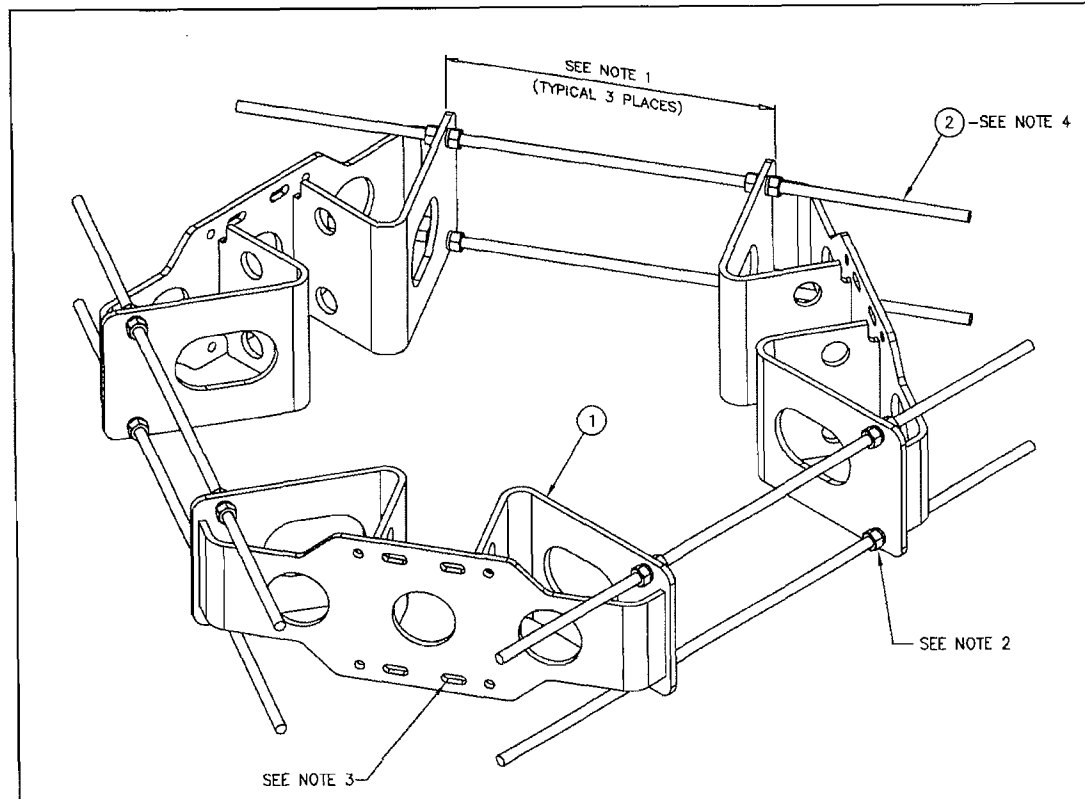

**NOTES:**

1. THIS DISTANCE MUST BE EQUAL IN ALL (3) THREE LOCATIONS TO ENSURE THE STRUCTURAL INTEGRITY OF THE THREADED RODS AS WELL AS 120° SEPARATION.
2. FOR MONOPOLES 13" DIA. OR SMALLER, ONLY (1) ONE NUT AND (1) ONE LOCKWASHER ARE REQUIRED BETWEEN THE TRI-COLLAR BRACKETS. FOR MONOPOLES LARGER THAN 13" DIA., (2) TWO NUTS AND (2) TWO LOCKWASHERS ARE REQUIRED BETWEEN THE TRI-COLLAR BRACKETS.
3. THE MOUNTING SLOTS NOTED WILL ACCOMMODATE 2 3/8"-4 1/2" O.D. MOUNTING PIPES.
4. THREADED ROD MAY BE SHORTENED IF REQUIRED, FIELD CUT AND COLD GALV SPRAY TO SUIT.

ISOMETRIC VIEW

UNLESS OTHERWISE SPECIFIED ALL DIMENSIONS INCLUDE FINISHES AND ARE IN INCHES		MATERIAL:
TOLERANCES: FRACTIONS ± 1/16" ANGLES ± 1/2 DEG. DECIMALS ± .010"		TOLERANCES DO NOT APPLY TO RAW MATERIAL
REV	DATE	DESCRIPTION
1	1/8/10	WILSON REMBRAN N AUTOCAD



**CONFIDENTIAL**  
This document and the information contained herein is the confidential trade secret property of Sabre Communications Corporation ("Sabre") and must not be reproduced, copied or used, in whole or in part, for any purpose without the prior written consent of Sabre.  
© 2014 Sabre Communications Corporation. All rights reserved.

TRI-COLLAR BRACKET ASSEMBLY  
FOR MONOPOLES (12"-60" DIA.)  
(CIRCUMFERENCE 37.7" TO 188.5")

DATE	8/21/09	SIZE	B	DRAWING NO.	C10112301	REV	1
DRAWN BY	JV	SCALE	None	PAGE	1 OF 1		
CHECKED BY	MLC						



C10851001 10'-12' PLATFORM W/MOUNTING PIPE HARDWARE

ITEM	QTY.	PART NO.	DESCRIPTION	WEIGHT
1.	3	CW00885	WELDMENT, CORNER PLATFORM	413
2.	3	CW00886	WELDMENT, PLATFORM ARM	309
3.	3	CS03276	CHANNEL, PLATFORM SPLICE	77
4.	3	CS02248	SADDLE CLAMP, PLATFORM	5
5.	12	C40026024	BOLT ASSEMBLY, 5/8 $\phi$ X 2 1/4 A325	6
6.	6	C40026023	BOLT ASSEMBLY, 5/8 $\phi$ X 2 A325	3
7.	24	C40026022	BOLT ASSEMBLY, 5/8 $\phi$ X 1 3/4 A325	11
8.	24	C40034023	U-BOLT ASSEMBLY, 5/8 $\phi$ X 3 1/16 C-C	40
9.	6	CS02317	PLATE, U-BOLT SPACER	14
TOTAL WEIGHT				878

NOTE:  
HARDWARE KIT CK00378 CONSISTS  
OF ITEMS 4 THRU 9 LISTED ABOVE

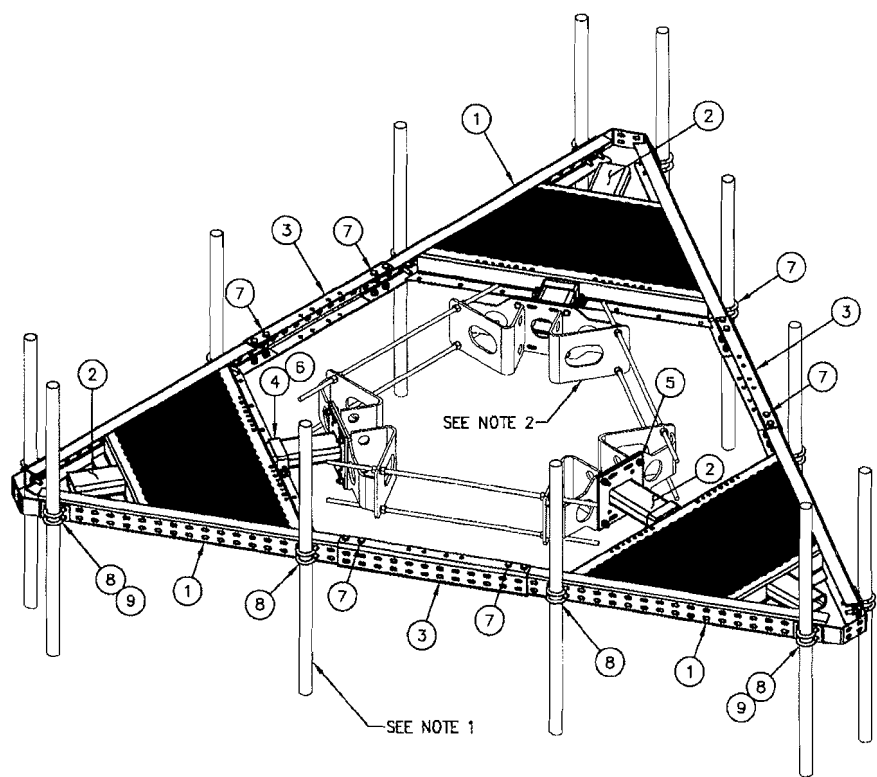

ISOMETRIC VIEW  
12' PLATFORM SHOWN

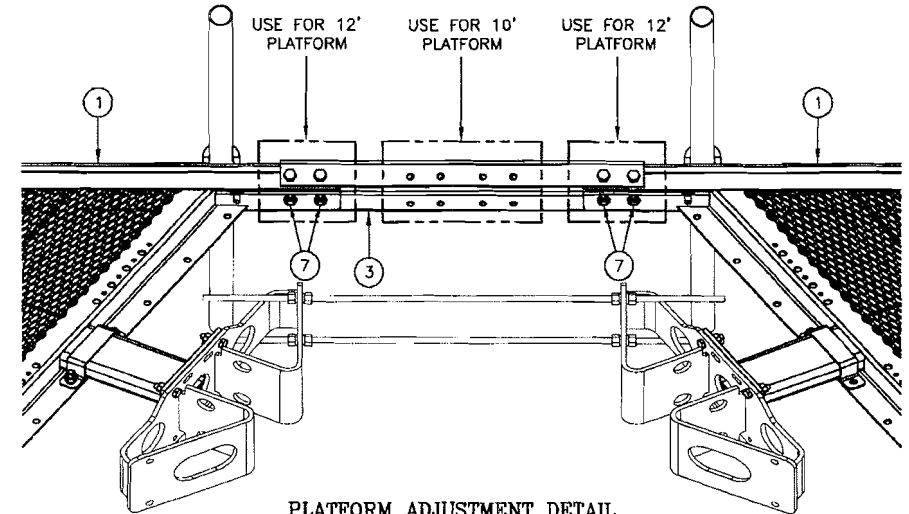

PLATFORM ADJUSTMENT DETAIL  
TO ADJUST THE PLATFORM FACE WIDTH, SLIDE THE CORNER WELDMENTS IN  
OR OUT TO THE CORRESPONDING HOLES ON THE PLATFORM CHANNEL SPLICE

UNLESS OTHERWISE SPECIFIED ALL DIMENSIONS INCLUDE FINISHES AND ARE IN INCHES		MATERIAL:
TOLERANCES: FRACTIONS $\pm 1/16$ " ANGLES $\pm 1/2$ DEG. DECIMALS $\pm .010$ "		TOLERANCES DO NOT APPLY TO RAW MATERIAL
REV	DATE	DESCRIPTION
1	07/23/15	WIRE FILE ITEM 3 WAS CS02247
2	07/21/15	NUMBER REVISIONS PER QTY QUANTITIES AND NOTE 2
3	12/29/10	QTY REVISED PART NUMBERS ON HANDRAIL BY NOTE 3
4	2/23/10	REVISION: RE-DRAWN IN AUTOCAD

**Sabre Industries**  
Towers and Poles

**CONFIDENTIAL**  
This document and the information  
contained herein is the confidential trade  
secret property of Sabre Communications  
Corporation ("Sabre") and must not be  
reproduced, copied or used, in whole or in  
part, for any purpose without the prior  
written consent of Sabre.  
© 2015 Sabre Communications Corporation.  
All rights reserved.

<b>10'-12' LOW PROFILE PLATFORM W/ANTENNA MOUNTING PIPE HARDWARE NO ANTENNA MOUNTING PIPES</b>			
DATE	10/22/09	SIZE	B
DRAWN BY	JV	DRAWING NO.	C10851001
CHECKED BY	WMN	SCALE	None
		PAGE	1 OF 1
		REV	4





C10116813 12' LOW PROFILE PLATFORM HANDRAIL KIT

ITEM	QTY.	PART NO.	DESCRIPTION	WEIGHT
1.	3	CS01533	PLATE, HANDRAIL SUPPORT	38#
2.	3	CS02229	PIPE, 1.90" O.D. (.145" WALL) X 12'-6"	106#
3.	3	C10981204	PIPE, 2 3/8" O.D. (.134" WALL) X 4'-0"	38#
4.	12	C40204100	CROSSOVER CLAMP (1.90" O.D. TO 2 3/8" O.D.)	48#
5.	12	C4003406D	U-BOLT ASSEMBLY, 1/2" Ø X 2 9/16" C/C	9#
6.	6	C40034023	U-BOLT ASSEMBLY, 5/8" Ø X 3 1/16" C/C	10#
TOTAL WEIGHT				249#

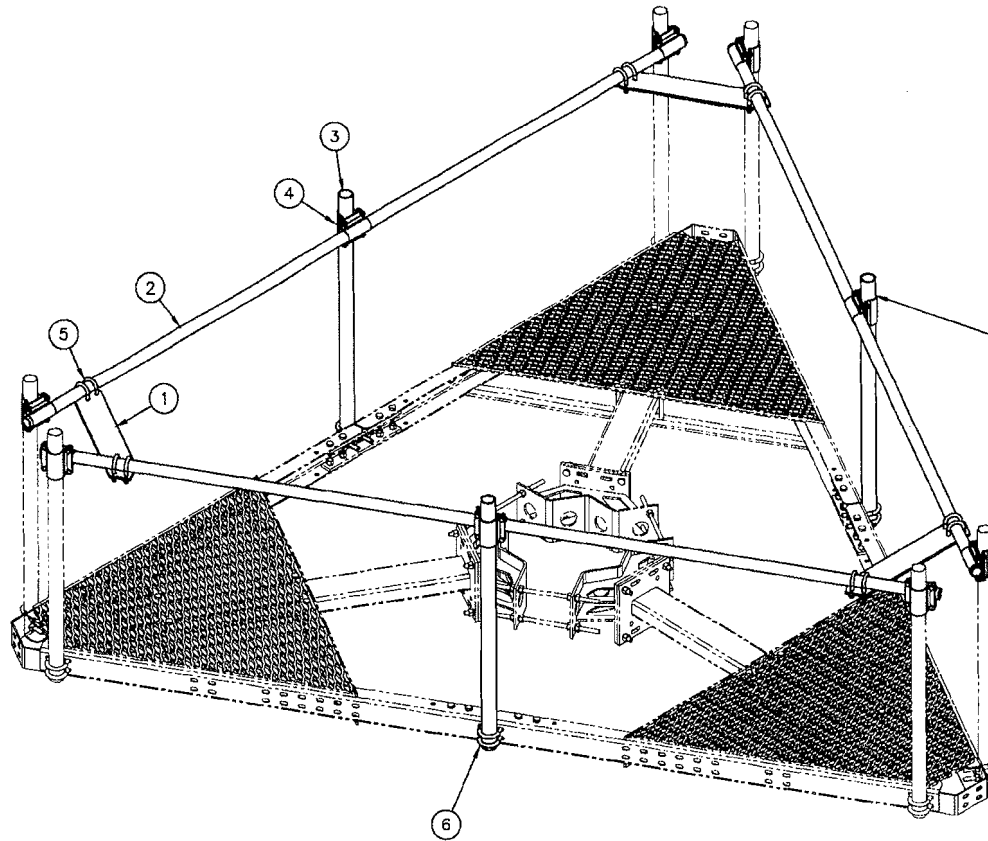

THIS PIPE MAY BE REPLACED WITH A LONGER PIPE IF NEEDED FOR ANTENNA MOUNTING (NOT REQ'D WITH 3 OR MORE MOUNTING PIPES PER FACE)

THERE ARE ENOUGH CLAMPS SUPPLIED TO ACCOMMODATE (12) ANTENNA MOUNTING PIPES - (4) PER FACE

ANTENNA MOUNTING PIPES TO BE PURCHASED SEPARATELY

ISOMETRIC VIEW

UNLESS OTHERWISE SPECIFIED ALL DIMENSIONS INCLUDE FINISHES AND ARE IN INCHES  
 TOLERANCES: FRACTIONS ± 1/16"  
 ANGLES ± 1/2 DEG.  
 DECIMALS ± .010"

MATERIAL:  
 TOLERANCES DO NOT APPLY TO RAW MATERIAL



**CONFIDENTIAL**  
 This document and the information contained herein is the confidential trade secret property of Sabre Communications Corporation ("Sabre") and must not be reproduced, copied or used, in whole or in part, for any purpose without the prior written consent of Sabre.  
 © 2014 Sabre Communications Corporation. All rights reserved.

12' LOW PROFILE PLATFORM HANDRAIL KIT  
 (12'-0" MAXIMUM ANTENNA SEPARATION)

REV	DATE	DRW/CHK	DESCRIPTION
5	6/27/11	MLC/MLC	ITEM 2 WAS CORRECTED (QTY PER REQUEST)
4	3/4/09	MLC/MLC	REVISED QUANTITY OF ITEM 4
3	1/15/08	MLC/MLC	REVISED ITEM 3
2	6/3/08	MLC/MLC	REVISED ITEM 4
1	10/11/07	MLC/MLC	12' LOW PROFILE PLATFORM DESIGN

DATE	7/31/07	SIZE	B	DRAWING NO.	C10116813	REV	5
DRAWN BY	MLC	SCALE	None	PAGE	1 OF 1		
CHECKED BY	MC						



**C10119103 3 FT. SIDEARM FOR MONOPOLE**

ITEM	QTY.	PART NO.	DESCRIPTION	WEIGHT
1.	1	C10151103	3 FT. SIDEARM KIT	82
2.	1	C10981405	PIPE, 4 1/2" Ø X .180 X 5'-3"	44
3.	6	C40034032	U-BOLT ASSEMBLY, 5/8" Ø X 5 3/16" C-C	17
<b>TOTAL WEIGHT</b>				<b>143</b>

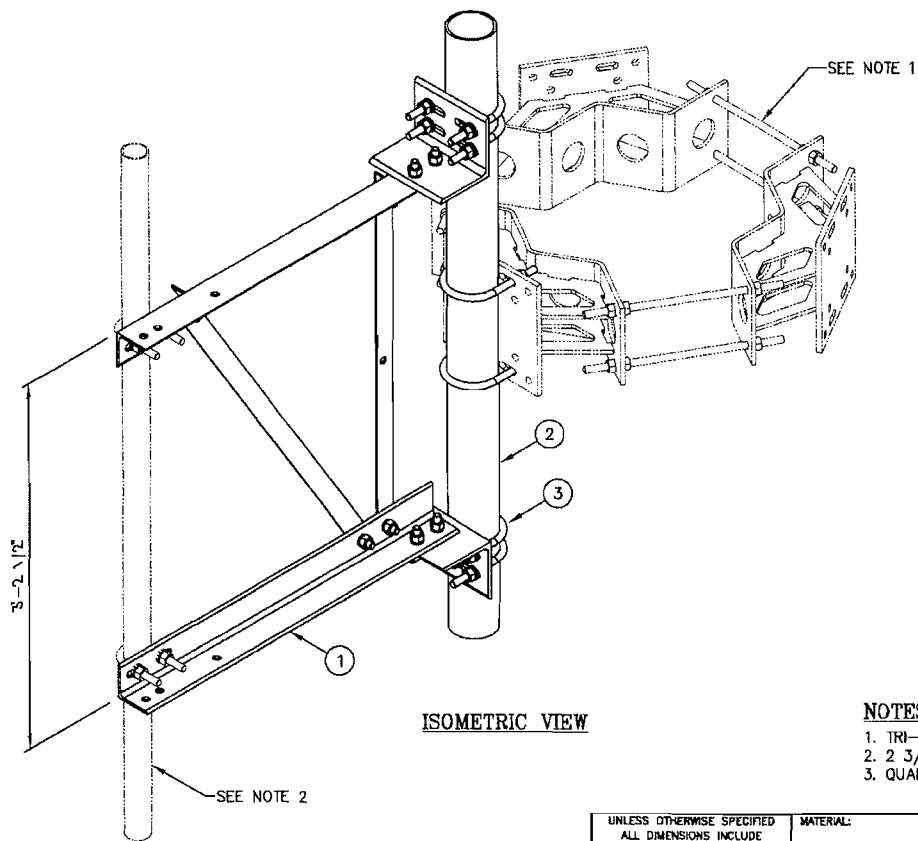

**ISOMETRIC VIEW**

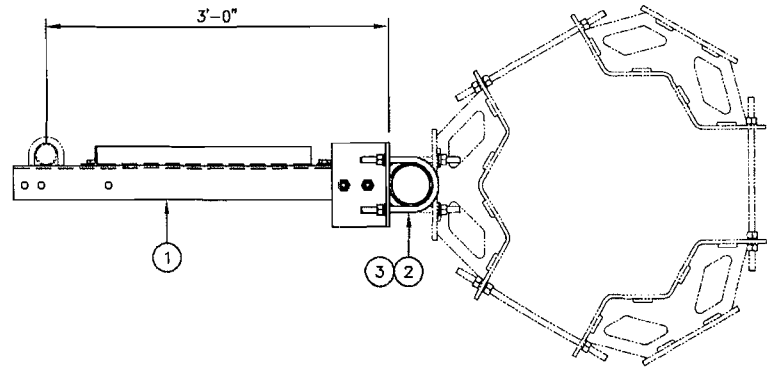

**PLAN VIEW**

**NOTES:**

1. TRI-COLLAR MOUNTS ARE SHOWN TYPICAL AND MUST BE ORDERED SEPARATELY.
2. 2 3/8" THRU 4" O.D. MOUNTING PIPE & U-BOLTS MUST BE PURCHASED SEPARATELY.
3. QUANTITIES SHOWN ARE FOR ONE (1) SIDEARM ONLY.

UNLESS OTHERWISE SPECIFIED ALL DIMENSIONS INCLUDE FINISHES AND ARE IN INCHES		MATERIAL:	
TOLERANCES: FRACTIONS ± 1/16" ANGLES ± 1/2 DEG. DECIMALS ± .010"		TOLERANCES DO NOT APPLY TO RAW MATERIAL	
REV	DATE	DRW/CHK	DESCRIPTION
1	11/14/08	MJC/MJC	REVISED PIPE (ITEM 2)
2	11/20/08	TRP/PAW	ADDED ISOMETRIC VIEW
3	01/12/08	MJC/MJC	UPDATED DRAWING

**Sabre Industries™**  
Towers and Poles

**CONFIDENTIAL**  
This document and the information contained herein is the confidential trade secret property of Sabre Communications Corporation ("Sabre") and must not be reproduced, copied or used, in whole or in part, for any purpose without the prior written consent of Sabre.  
© 2014 Sabre Communications Corporation. All rights reserved.

**3 FT. SIDEARM FOR MONOPOLE  
(FOR MTG. PIPES 2 3/8" O.D. THRU 4" O.D.)**

DATE	01/05/06	SIZE	B	DRAWING NO.	C10119103	REV	3
DRAWN BY	JKW	CHECKED BY	WJ	SCALE	None	PAGE	1 OF 1

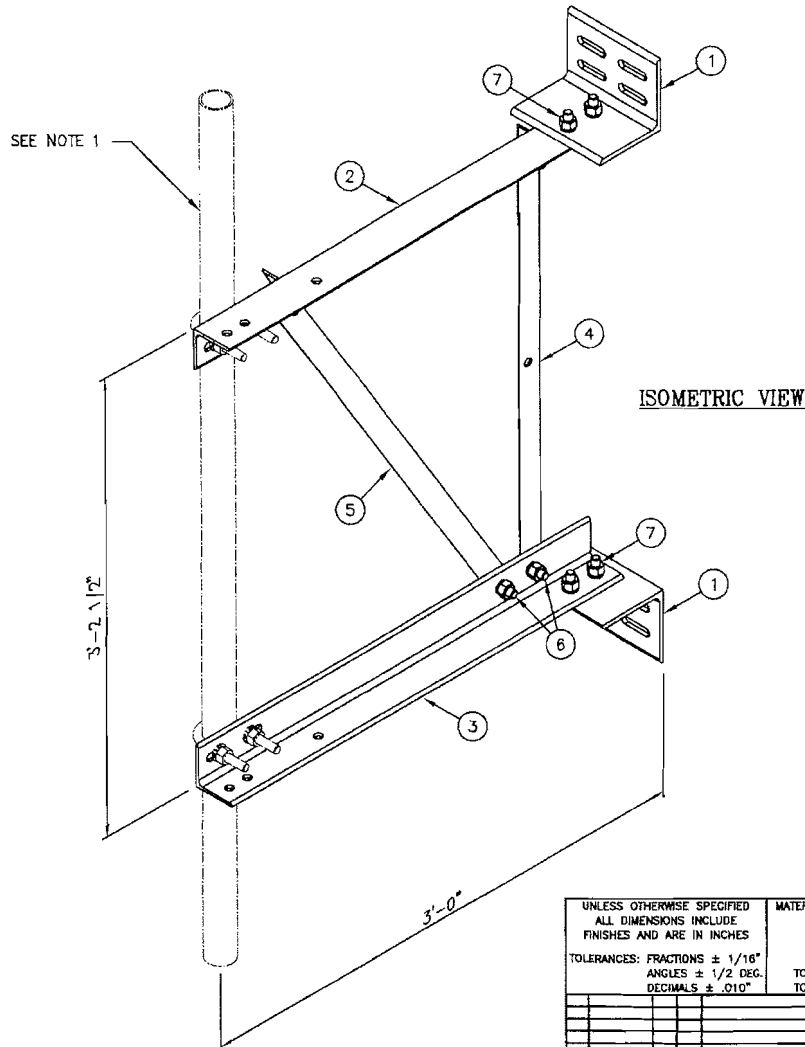

**C10151103 3 FT. SIDEARM ASSEMBLY**

(1)	CK00060	SIDEARM ANGLE KIT	78
(1)	---	MISC HARDWARE (FRAMING)	4
TOTAL WEIGHT			82

**CK00060 KIT LIST OF MATERIAL**

ITEM	QTY.	PART NO.	DESCRIPTION	WEIGHT
1.	2	CS00067	ANGLE, BOOM SUPPORT	23
2.	1	CS01223	ANGLE, TOP CHORD	19
3.	1	CS01224	ANGLE, BOTTOM CHORD	19
4.	1	CS00065	ANGLE, VERTICAL	8
5.	1	CS01228	ANGLE, DIAGONAL	9
TOTAL WEIGHT				78

**MISC HARDWARE (FRAMING)**

ITEM	QTY.	PART NO.	DESCRIPTION	WEIGHT
6.	4	C40026022	BOLT ASSEMBLY, 5/8 $\phi$ X 1 3/4 A325	2
7.	4	C40026023	BOLT ASSEMBLY, 5/8 $\phi$ X 2 A325	2
TOTAL WEIGHT				4

**NOTES:**

- 2 3/8" O.D. THRU 4" O.D. MOUNTING PIPE & U-BOLTS MUST BE PURCHASED SEPARATELY.
- QUANTITIES SHOWN ARE FOR ONE (1) SIDEARM ONLY.

UNLESS OTHERWISE SPECIFIED ALL DIMENSIONS INCLUDE FINISHES AND ARE IN INCHES		MATERIAL:
TOLERANCES: FRACTIONS $\pm 1/16"$ ANGLES $\pm 1/2$ DEG. DECIMALS $\pm .010"$		TOLERANCES DO NOT APPLY TO RAW MATERIAL
REV	DATE	DRW/CHK
1	11/10/08	WRP/WMN
		ADDED ISOMETRIC VIEW
		DESCRIPTION

**Sabre Industries**  
Towers and Poles

**CONFIDENTIAL**  
This document and the information contained herein is the confidential trade secret property of Sabre Communications Corporation ("Sabre") and must not be reproduced, copied or used, in whole or in part, for any purpose without the prior written consent of Sabre.  
© 2013 Sabre Communications Corporation. All rights reserved.

**3 FT. SIDEARM  
(FOR MTG. PIPES 2 3/8" O.D. THRU 4" O.D.)**

DATE	12/16/05	SIZE	B	DRAWING NO.	C10151103	REV	1
DRAWN BY	RWM	SCALE	None	PAGE	1 OF 1		
CHECKED BY	MWR						



CUSTOMER: **BOONE COUNTY**  
 SITE: **Battle School, MO**  
 SITE NO:  
 DESC: **171.00 ft. WIRELESS MONOPOLE**  
 P.O. NO:

**1**

PC=PIECE OR=ORANGE  
 PLT=PALLET WH=WHITE  
 BDL=BUNDLE O/W=OR & WH  
 CRT=CRATE B=BARE  
 D=DRUM N/R=NOT REQ'D  
 BOX=BOX SP=SPECIAL

**PACKING**

Item	Qty	DRAWING		Part No.	Description	Total Weight	FINISH	Qty/ PKG'S	Qty of PKG'S	PKG. NO.
		NUMBER	REV.							
<b>POLE SECTIONS</b>										
1	1			MR1307270110	24'-9 Top Section	1543	G			
2	1			MR1307270120	53'-6 Top Mid Section	5653	G			
3	1			MR1307270130	53'-6 Bottom Mid Section	10834	G			
4	1			MR1307270140	53'-3 Bottom Section w/ Base	15680	G			
						<b>TOTAL POLE SHAFT WEIGHT:</b>	<b>33,710</b>	<b>lbs</b>		
<b>ANCHOR BOLTS &amp; TEMPLATES</b>										
5	18			C40041007	2-1/4" X 7'-0" (ASTM A615 GRADE 75) OR EQUAL	2239	G			
6	2			130727-9001	ANCHOR BOLT TEMPLATES (w/ 66.5" Bolt Circle)	206	Black			
<b>MISCELLANEOUS ITEMS</b>										
7	161			C40044002	5/8"-11 X 7" STEP BOLT (GALV)	178	A-307			
8	7			C40011001	STEP BOLT ANCHOR BRACKET	1	A-36			
9	8			C30136002	6.5" X 12.5" X 0.1875PL ACCESS COVER (GALV)	38	A-36			
10	9			C30136021	8.5" X 20.5" X 0.1875PL ACCESS COVER (GALV)	90	A-36			
11	4			C30136001	11.0" X 26.0" X 0.1875PL ACCESS COVER (GALV)	60	A-36			
12	1			C30170011	TOP COVER KIT 12" TO 16"	39	A-36			
13	1			C40068001	13OZ CAN OF COLD GALV SPRAY	1	--			
14	1			CS00500	NAME PLATE	1	--			

REV	DATE	DRF	CHK	DESCRIPTION
1	11/9/15	DLK	WJ	CHANGED POLE HEIGHT AND DESIGN

DATE: <b>27-Oct-15</b>	JOB NO: <b>130727</b>
DRAWN BY: <b>DLK</b>	DRAW NO: <b>BOM-1</b>
CHK'D BY: <b>WJ</b>	PAGE: <b>1 of 2</b>





**MALICOAT - WINSLOW ENGINEERS, P.C.**  
 MISSOURI STATE CONTRACT & ARCHITECT FIRM #1  
 5640 N. CLEARVIEW ROAD  
 COLUMBIA, MISSOURI 65202  
 TEL: 573-675-1300  
 FAX: 573-675-1305  
 FREDDIE MALCOAT, P.E.

**JOINT COMMUNICATIONS**  
 2600 BATTLE AVENUE  
 COLUMBIA, BOONE COUNTY, MISSOURI, 65202

CONTRACTOR SHALL CHECK ALL VENT ALL DIMENSIONS & CONDITIONS AT JOB SITE.  
 DATE: 06-29-15  
 REVISIONS:  
 10-20-15  
 TITLE: MECHANICAL/ELECTRICAL PLAN  
 SHEET: ME1 of ME1  
 PROJECT: 15171

### ELECTRICAL SYMBOL SCHEDULE

HOME RUN CIRCUIT TO PANEL, P1, CIRCUITS 22,24  
 EACH HATCH INDICATES ONE CIRCUIT  
 SHORT HATCH MARKS INDICATE # OF PHASE CONDUCTORS  
 LONG HATCH MARKS INDICATE # OF NEUTRAL CONDUCTORS  
 NO HATCH MARK INDICATES TWO CONDUCTORS

ELECTRICAL SYMBOL FOR TYPICAL WIRING

WIRING IN WALL OR CEILING - WIRING IN FLOOR

RECEPTACLE CABLE (EXCEPT - DISCONNECTS - SPLIT WIRING - SPECIAL POWER)  
 COMMUNICATIONS CABLE (TELEPHONE - DATA - DATA/PHONE)

WALL SWITCH SINGLE POLE (3-WAY - DIMMER - 4-WAY - PUT - SPEED - KEYS - TRIP)  
 INCANDESCENT OR HID LIGHT FIXTURE (CEILING MOUNTED - WALL MOUNTED)  
 FLUORESCENT LIGHT FIXTURE (ENCLOSURED - STRIP) (S INDICATES SPRAY WIRE)  
 EXIT LIGHT - EMERGENCY LIGHT - EMERGENCY/EXIT LIGHT

CLOCK RECEPTACLE  
 ELECTRIC PANO.  
 SPEAKER - PUSH TO TALK

FUNCTION BOX - FULL BOX  
 DISCONNECT SWITCH - HANGING  
 SWITCH

OUTLET HEIGHT INDICATES INCHES - OR PROTECTED - WEATHER PROOF GFI

### MECHANICAL SYMBOL SCHEDULE

PIPE FITTINGS (ALL DOWN - SEE DOWN - TEE UP)  
 VALVE - CHECK VALVE  
 UNION - STRAINER  
 GAS COCK - BALANCING COCK

### P1

VOLTS	120/240	PHASE	1	NEUTRAL	2	WIRE CAPACITY	200A MLO	A WATS	6500	B WATS	6400
WIRE											
AC											
								100A	WATS	13,000	

CIRC	LOCATION / DESCRIPTION	SECTOR	WATS	#	SECTOR	LOCATION / DESCRIPTION	CIRC
1	RECEPTACLES	20-1	1,000	A	2,500	20-2	2
3	RECEPTACLES	20-1	720	B	2,500		4
3	LIGHTS	20-1	300	A	2,500	20-2	6
3	RECEPTACLE	20-1	180	B	2,500		8
3	RECEPTACLE	20-1	540	A	0		10
11	RECEPTACLE	20-1	540	B	0		12
13		0	A	0			14
15		0	B	0			16
17		0	A	0			18
19		0	B	0			20
21		0	A	0			22
23		0	B	0			24
25		0	A	0			26
27		0	B	0			28
29		0	A	0			30

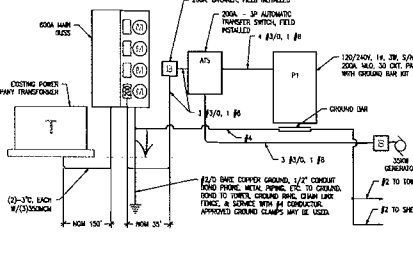

**3 ELECTRIC RISER DIAGRAM**  
 NOT TO SCALE

- ### GENERAL MECHANICAL-ELECTRICAL SPECIFICATIONS
- ALL WORK SHALL BE DONE IN STRICT ACCORDANCE TO THE BUILDING CODES OF THE CITY OF COLUMBIA, MO.
  - ALL MATERIALS SHALL BE NEW, FIRST CLASS, AND INSTALLED TO MANUFACTURER'S WRITTEN SPECIFICATIONS.
  - ALL SYSTEMS SHALL BE COMPLETE AND OPERABLE IN EVERY WAY.
  - ON ALL EXCAVATION, DRILLING, CUTTING, FITTING, OPERATING, ADJUSTING AND PAINTING AS REQUIRED TO COMPLETE THE JOB.
  - SPECIAL MEASURES ARE PROVIDED TO GUARANTEE QUALITY ONLY. WORKER'S DISCRETION SHALL BE FINAL ON ALL NATIONAL SPECIFICATIONS OR SPECIFICATIONS.
  - MAINTAIN SAFETY SIGNS AND BARRELS AS REQUIRED TO ASSURE SAFE WORKING CONDITIONS.
  - CHARITATE ALL WORKMANSHIP AND MATERIALS FOR ONE YEAR FROM FINAL ACCEPTANCE.
  - EACH CONTRACTOR SHALL BE RESPONSIBLE FOR CLEANING UP HIS OWN DEBRIS.
  - CONTRACTOR SHALL NOT BE RESPONSIBLE FOR PROPER OPERATION OF OWNER-FURNISHED MATERIALS.
  - INSPECT JOB SITE PRIOR TO BEGINNING TO DETERMINE EXACT JOB REQUIREMENTS.
  - ONE POINT ABOVE OR BELOW GRADE SHALL BE CORRECT TYPING OR MEAN DENSITY POLYETHYLENE DISCREPANCY, 6500 OR 1000.

- ### PLUMBING SPECIFICATIONS
- SEE GENERAL MECHANICAL-ELECTRICAL SPECIFICATIONS.
  - ONE POINT ABOVE OR BELOW GRADE SHALL BE CORRECT TYPING OR MEAN DENSITY POLYETHYLENE DISCREPANCY, 6500 OR 1000.

- ### ELECTRICAL SPECIFICATIONS
- SEE GENERAL MECHANICAL-ELECTRICAL SPECIFICATIONS.
  - ALL CONDUCTORS SHALL BE COPPER UNLESS #12 OR LARGER AS REQUIRED OR SHOWN.
  - ALL EQUIPMENT SHALL BE RATED FOR 75 C CONDUCTORS.
  - ALL SCHEMATIC WIRING, BEING EXPOSED TO WEATHER OR BEING BELOW GRADE, SHALL BE IN RIGID GALVANIZED CONDUIT OR SCH 40 PVC.
  - ALL WIRING IN NON-FIRE-RATED CONSTRUCTION MAY BE NON-METALLIC SHEATHED CABLE (NMCA).
  - ALL OTHER WIRING SHALL BE IN LIFT OR MC CABLE.
  - WALL SWITCHES SHALL BE LEVON #1100 SERIES, OR APPROVED EQUAL, 20A.
  - SWITCH CONDUIT RECEPTACLES SHALL BE LEVON #300 SERIES OR APPROVED EQUAL, 20A. CHANGING TYPE, CHANGING TYPE RECEPTACLES SHALL BE LEVON #300A-18 SERIES, USE SCORING ONLY, NOT DUCKTAIL.
  - SPECIAL OUTLETS SHALL BE AS REQUIRED OR SHOWN ON DRAWINGS, COMPLETE WITH COVER PLATE.
  - THE ENTIRE SYSTEM SHALL BE ELECTRICALLY CONTINUOUS AND PROPERLY GROUNDING. EVERY FITTING AND SWITCH COMPONENT SHALL HAVE GOOD SIZED DRAIN INSULATED GROUND CONNECTION.
  - FURNISH AND INSTALL ALL LIGHTING FIXTURES, LAMPS, FLUORESCENTS, ETC. TO COMPLETE THE BRANCH CIRCUITS DESIGN.
  - ALL LAMP, FOR LIGHTING AND RECEPTACLE CIRCUITS REQUIRING MORE THAN 100' OF CONDUCTORS (ONE WAY) SHALL BE #10 CONDUCTORS.

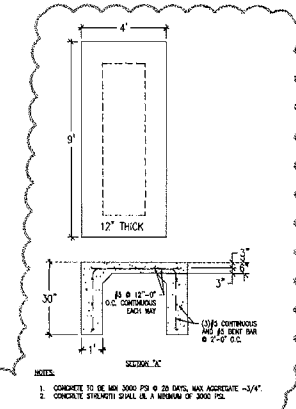

**5 PROPANE PAD DETAIL**  
 ME1 SCALE: NO SCALE

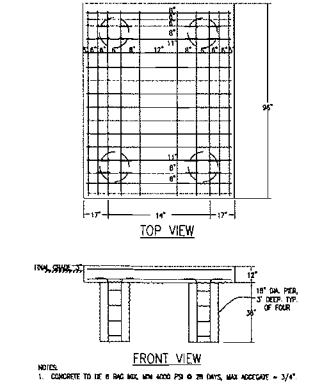

**4 GENERATOR PAD DETAIL**  
 ME1 SCALE: NO SCALE

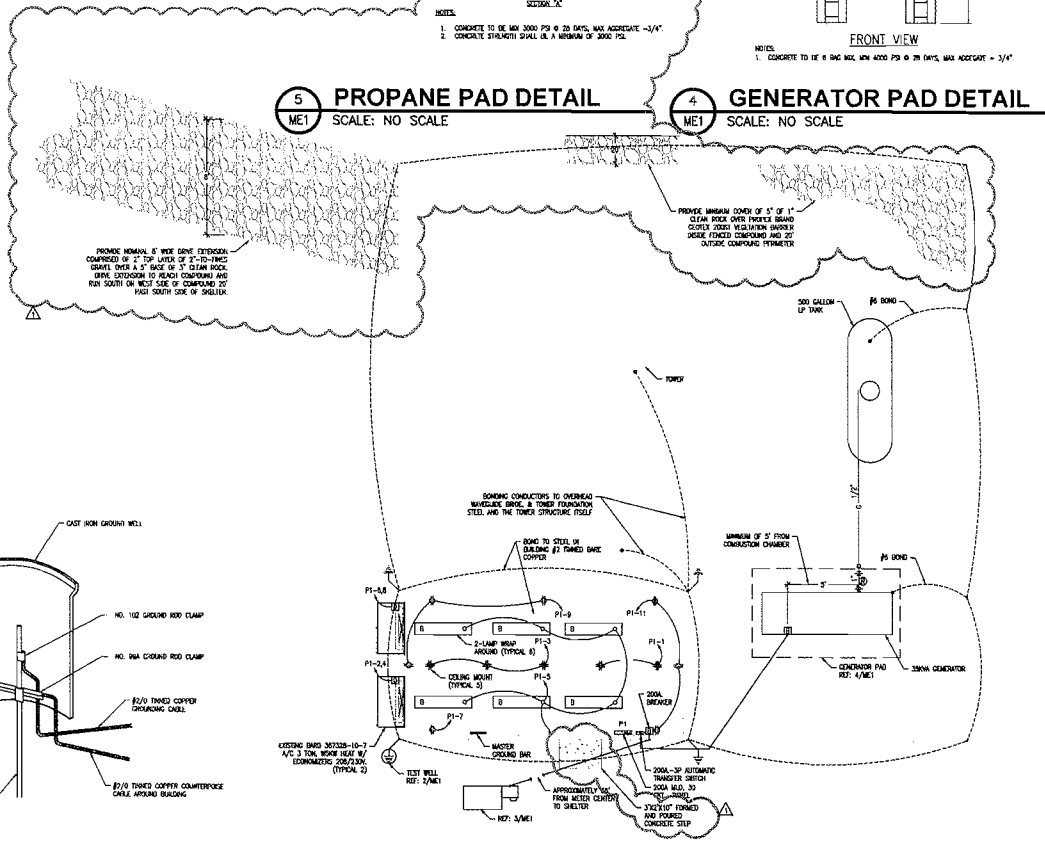

**2 GROUND WELL**  
 ME1 NO SCALE

**1 SITE PLAN FINAL CONFIGURATION**  
 ME1 SCALE: 1/4" = 1'-0"

# CERTIFIED COPY OF ORDER

STATE OF MISSOURI }  
County of Boone } ea.

January Session of the January Adjourned

Term. 20 16

In the County Commission of said county, on the 7th day of January 20 16

the following, among other proceedings, were had, viz:

Now on this day the County Commission of the County of Boone does hereby approve the closure of a section of Backbone Road located in the SW ¼ of Section 34, Township 47 North, Range 11 West. The section of road being closed by this action is 5,915 feet south of the intersection with Englewood Road. Boone County records show that there has been no expenditure of public funds or use of county manpower for maintenance purposes on this section of road for more than five years. This section of Backbone Road is not publicly maintained and closing this section will not deny access to any property owner to a public road.

The Commission further states that an appropriate traffic control barrier may be placed to impede traffic from access to the closed section of roadway.

A map showing the closed section of road and the location of the traffic control barrier is attached to this order.

Done this 7th day of January, 2016.

ATTEST:

Wendy S. Noren  
Wendy S. Noren  
Clerk of the County Commission

Daniel K. Atwill  
Presiding Commissioner

Karen M. Miller  
District I Commissioner

Janet M. Thompson  
District II Commissioner

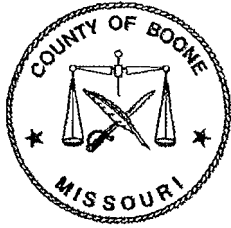

# Boone County Resource Management

ROGER B. WILSON BOONE COUNTY GOVERNMENT CENTER  
801 E. WALNUT ROOM 315 COLUMBIA, MO 65201-7730  
(573) 886-4330 FAX (573) 886-4340

STAN SHAWVER, DIRECTOR

PLANNING – INSPECTIONS – ENGINEERING

DERIN CAMPBELL, CHIEF ENGINEER

## Sign Inventory System Notice

Date: October 28, 2013

Road Name: Backbone Rd

Segment Number: 2601

Asset Change #: CM-2013-032

Location: 5,915' (1.12 mi) south of Englewood Rd  
(x = 1739666, y = 1081918)

Action: The proposed County maintenance ends sign has been approved for installation at the following location.

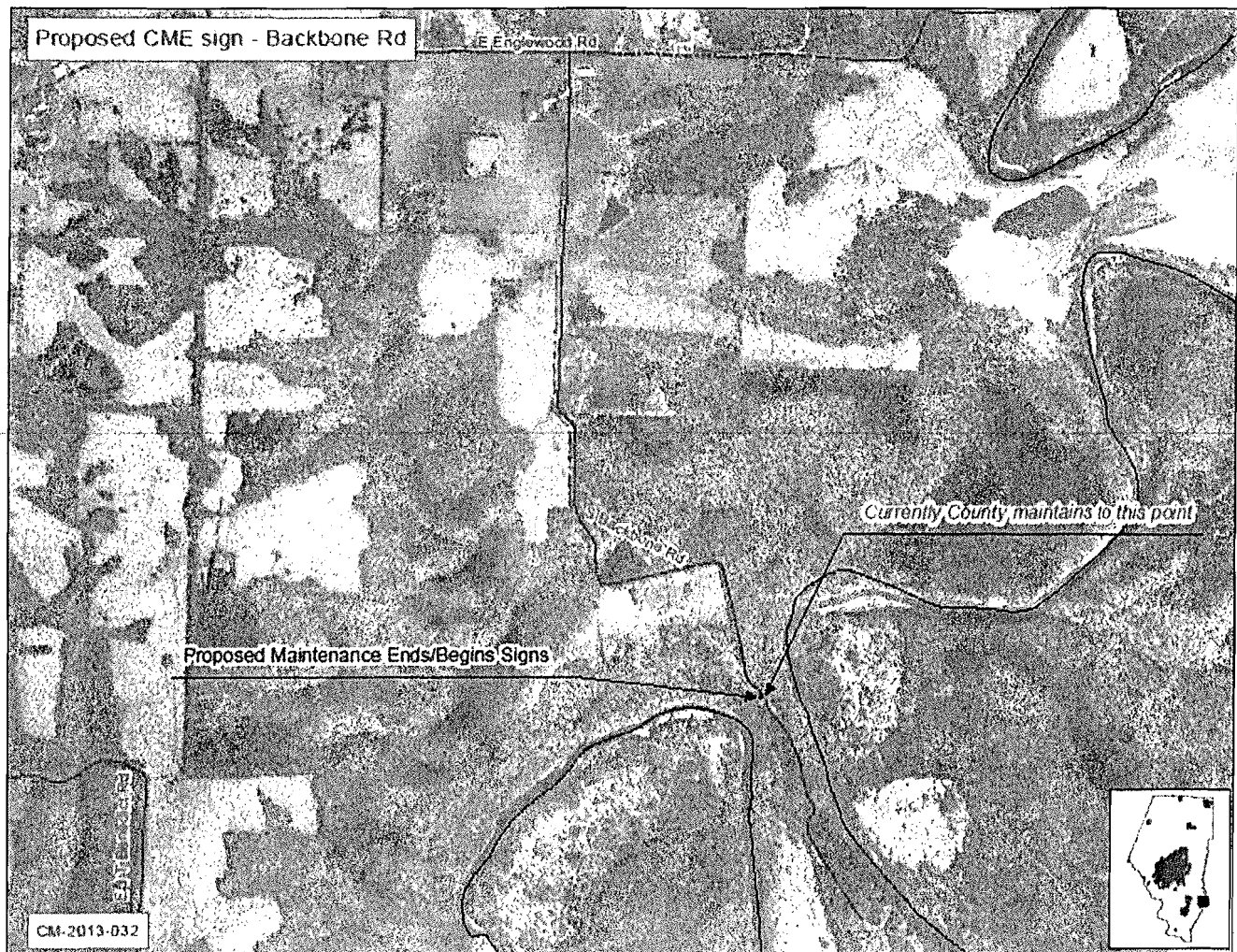



# CERTIFIED COPY OF ORDER

STATE OF MISSOURI }  
County of Boone } ea.

January Session of the January Adjourned

Term. 20 16

In the County Commission of said county, on the 7th day of January 20 16

the following, among other proceedings, were had, viz:

Now on this day the County Commission of the County of Boone does hereby approve the Organizational Use of the Government Center Conference Room 301 by the Department of Mental Health for February 24, 2016 from 9:00 a.m. to 2:00 p.m.

Done this 7th day of January, 2016.

ATTEST:

Wendy S. Noren  
Wendy S. Noren  
Clerk of the County Commission

[Signature]  
Daniel K. Atwill  
Presiding Commissioner

[Signature]  
Karen M. Miller  
District I Commissioner

Absent  
Janet M. Thompson  
District II Commissioner



# Boone County Commission

## APPLICATION FOR ORGANIZATIONAL USE OF BOONE COUNTY CONFERENCE ROOMS

The undersigned organization hereby applies for a use permit to use Boone County Government conference rooms as follows:

Organization: Department of Mental Health (DMH)

Address: 1706 E. Elm St.

City: Jefferson City State: MO ZIP Code 65101

Phone: 573-751-7249 Website: \_\_\_\_\_

Individual Requesting Use: Melanie Bullard, RD, JD Position in Organization: Dietetic Services Coordinator

Facility requested:  Chambers  Room 301  Room 311  Room 332  Centralia Clinic

Event: DMH Dietetic Services Quarterly Meeting

Description of Use (ex. Spcaker, meeting, reception): Business Meeting

Date(s) of Use: 02/24/2016 - Wednesday

Start Time of Setup: 9:00 a.m. AM/PM Start Time of Event: 10:00 a.m.

End Time of Event: 2:00 p.m. AM/PM End Time of Cleanup: 2:00 p.m.

The undersigned organization agrees to abide by the following terms and conditions in the event this application is approved:

1. To abide by all applicable laws, ordinances and county policies in using Boone County Government conference rooms.
2. To remove all trash or other debris that may be deposited (by participants) in rooms by the organizational use.
3. To repair, replace, or pay for the repair or replacement of damaged property including carpet and furnishings in rooms.
4. To conduct its use in such a manner as to not unreasonably interfere with Boone County Government building functions.
5. To indemnify and hold the County of Boone, its officers, agents and employees, harmless from any and all claims, demands, damages, actions, causes of action or suits of any kind or nature including costs, litigation expenses, attorney fees, judgments, settlements on account of bodily injury or property damage incurred by anyone participating in or attending the organizational use of rooms as specified in this application.

Organization Representative/Title: Melanie Bullard, RD, JD, DMH Dietetic Services Coordinator

Phone Number: 573-751-7249 Date of Application: 12/29/2015

Email Address: melanie.bullard@dmh.mo.gov

Applications may be submitted in person or by mail to the Boone County Commission, 801 E. Walnut, Room 333, Columbia, MO 65201 or by email to [commission@boonecountymo.org](mailto:commission@boonecountymo.org).

## PERMIT FOR ORGANIZATIONAL USE OF BOONE COUNTY GOVERNMENT CONFERENCE ROOMS

The County of Boone hereby grants the above application for permit in accordance with the terms and conditions above written. The above permit is subject to termination for any reason by duly entered order of the Boone County Commission.

ATTEST:

Wendy S. Noweany  
County Clerk

BOONE COUNTY, MISSOURI

[Signature]  
County Commissioner

DATE: 1-7-16

# CERTIFIED COPY OF ORDER

STATE OF MISSOURI

January Session of the January Adjourned

Term. 20 16

County of Boone

} ea.

In the County Commission of said county, on the

7th

day of January

20 16

the following, among other proceedings, were had, viz:

Now on this day the County Commission of the County of Boone does hereby approve the Organizational Use of the Government Center Chambers by Missouri for Liberty for February 8, March 14 and April 11, 2016 from 7:00 p.m. to 9:00 p.m.

Done this 7th day of January, 2016.

ATTEST:

Wendy S. Noren  
Wendy S. Noren  
Clerk of the County Commission

Daniel K. Atwill  
Daniel K. Atwill  
Presiding Commissioner

Karen M. Miller  
Karen M. Miller  
District I Commissioner

Absent  
Janet M. Thompson  
District II Commissioner



# Boone County Commission

## APPLICATION FOR ORGANIZATIONAL USE OF BOONE COUNTY CONFERENCE ROOMS

The undersigned organization hereby applies for a use permit to use Boone County Government conference rooms as follows:

Organization: Missouri For Liberty  
Address: P.O. Box 30572, Columbia, Mo, 65205  
City: Columbia State: MO ZIP Code: 65205  
Phone: 319-360-4171 Website: Moforliberty.com  
Individual Requesting Use: Sean Reberry Position in Organization: Chairman  
Facility requested:  Chambers  Room 301  Room 311  Room 332  Centralia Clinic  
Event: Meeting  
Description of Use (ex. Speaker, meeting, reception): Meeting for discussion  
Date(s) of Use: 2<sup>nd</sup> Monday of the Month  
Start Time of Setup: 7 AM/PM Start Time of Event: 7 AM/PM  
End Time of Event: 9 AM/PM End Time of Cleanup: 9 AM/PM

The undersigned organization agrees to abide by the following terms and conditions in the event this application is approved:

1. To abide by all applicable laws, ordinances and county policies in using Boone County Government conference rooms.
2. To remove all trash or other debris that may be deposited (by participants) in rooms by the organizational use.
3. To repair, replace, or pay for the repair or replacement of damaged property including carpet and furnishings in rooms.
4. To conduct its use in such a manner as to not unreasonably interfere with Boone County Government building functions.
5. To indemnify and hold the County of Boone, its officers, agents and employees, harmless from any and all claims, demands, damages, actions, causes of action or suits of any kind or nature including costs, litigation expenses, attorney fees, judgments, settlements on account of bodily injury or property damage incurred by anyone participating in or attending the organizational use of rooms as specified in this application.

Organization Representative/Title: Sean Reberry, Chairman  
Phone Number: 319-360-4171 Date of Application: 4/12/15  
Email Address: seanreberry@gmail.com

Applications may be submitted in person or by mail to the Boone County Commission, 801 E. Walnut, Room 333, Columbia, MO 65201 or by email to [commission@boonecountymo.org](mailto:commission@boonecountymo.org).

## PERMIT FOR ORGANIZATIONAL USE OF BOONE COUNTY GOVERNMENT CONFERENCE ROOMS

The County of Boone hereby grants the above application for permit in accordance with the terms and conditions above written. The above permit is subject to termination for any reason by duly entered order of the Boone County Commission.

ATTEST:

Wendy S. Nowe  
County Clerk

BOONE COUNTY, MISSOURI

[Signature]  
County Commissioner

DATE: 1-7-16